

## Contents

Business Success Depends on the Practices of Effective Communication through KISS Principles. Md. Rofiqul Islam <sup>1</sup>	1
An Overview on the Problems and Prospects of Training in Banking Sector of Bangladesh. Md. Azmir Hossain <sup>1</sup>	12
The (G/G) expansion method for exact traveling wave solutions of second order non linear differential equation. Md. Anisur Rahman Pramanik <sup>1</sup>	27
An Invisible Watermarking Technique for Ownership Verification of Digital Images using Two Dimensional Discrete Cosine Transformation. K.M Ibrahim Khalilullah <sup>1</sup> , Md. Habibullah Belali <sup>2</sup> , Md. Tanvir Hamid <sup>3</sup>	32
Effect of thermophoresis on unsteady MHD forced convective heat and mass transfer flow along a wedge. ATM M. Rahman <sup>1</sup> , M.K. Chowdhury <sup>2</sup>	44
Social Awareness in William Blake's Poetry. Syed Ainal Huque <sup>1</sup>	59
John Keat's Personal Life and Literary Contemplation Reflect in His Letters. Dr. Md. Shah Alam Chowdhury <sup>1</sup>	68
Spiritualism Reveals in W.B. Yeats' Poetry. Mili Rahman <sup>1</sup>	76
Nature of Supernatural treatment in Coleridge's poetry. Dr. Sazzad Hossain*	84
Human Rights in Islam: Some Universal Fundamental Rights for Humanity. Mahua Gulfan <sup>1</sup>	93
The Laws and Practice regarding Confessional Statements: A Critical Analysis. Sadia Yeasmin*	106
Validated RP-HPLC method for the estimation of Halobetasol propionate in bulk and topical pharmaceutical preparation. Moynul Hasan <sup>1</sup> , Md. Mahfuzur Rahman <sup>2</sup> , Abdullah Al Masud <sup>3</sup>	119

Evaluation of antinociceptive activity of ethanolic extract and other fractions of <i>Desmodium pulchellum</i> (Fabaceae) bark in mice. Zebunnesa Ahmed <sup>1</sup> , Mohammad Saydur Rahman <sup>2</sup> , G.M Alamin <sup>3</sup>	126
Exposure to Mass Media, National Health Message and HIV/AIDS Campaign in Bangladesh: Challenges and Prospects. Masum Billah <sup>1</sup>	133
Sociocultural Constraints, Sexual Violence and Dropouts at School Level: A New Challenge for Bangladesh. Tahmina Khan <sup>1</sup>	144
Class Consciousness of Workers in Garments Industry in Bangladesh. Abdur Rahim Mollah <sup>1</sup>	154
Role of Literature in Awakening of the Muslims of Bengal. Humaira Momen*	161

# Business Success Depends on Practices of Effective Communication through KISS Principles

**Md. Rofiqul Islam**

**Abstract:** Communication touches every aspect of human activity. Business communication is the communication which is used to promote a product, service or organization with the objective of making sales. In business communication, messages are conveyed through various channels of communication, including press, internet, publications, radio, television, outdoor and word of mouth. This study examined the instructions regarding the importance of principles of business communication. Yet the literature also suggested that different objectives may elicit dissimilar opinions regarding specific types of principles that constitute the ability to communicate effectively. In response to the need for more precise communication KISS principle developed different skills based on organizational leadership and interpersonal abilities. The purpose of this study is to investigate the impact of business communication on organizational performance in the organizations. The results from this study show that maximum organizational success of a business comes through KISS principles of communication

**Key Words:** KISS, Principle, Communication, Success,

## **Introduction**

Communication is a system through which people share ideas, feelings, thoughts, facts, values, opinions and emotions with each other. The central objective of the communication process is the transmission of meaning. The process is successful only when the receiver understands the idea the sender intended it. Both parties must agree not only on the information transmitted but also on the meaning of the information. Effective communication in business is not about creating the perfect PowerPoint presentation. Business communication is the expression, changing, receiving, and interchanging of ideas, news and views in connection with the commerce and industry. Clarity is the “most serious communication problem in business.” The need for clarity is documented in other studies on the topic: Feinberg and Pritzker found that the three most important attributes that executives demand in complex communication are clarity, concision and logic. Linguistic research has found that messages are easy to understand if they are simple (familiar), well structured, short and stimulating (i.e., directly address the reader and provide examples)<sup>1</sup>. Needless to say, short sentences without relative clauses, with familiar words instead of jargon, and informative titles contribute to clarity. Psychological research has examined clarity in a domain called cognitive load theory. Cognitive load theory argues that many traditional ways of communication do not adequately take the limitations of human information processing into account, as they unnecessarily overload the audience’s working.<sup>2</sup>

Clarity of expression plays a critical role in today’s corporate communication, especially when it comes to complex topics such as crisis, strategy, and brand or risk communication. To improve the effectiveness of corporate communication, managers need to pay particular attention to the clarity of their messages to ensure that they do not create misunderstandings. The following typical business communication challenges illustrate the relevance of clarity in corporate communication:

---

Associate Professor, Department of Business Administration, Faculty of Business Studies, Dhaka International University, Dhaka, Bangladesh, **E-mail:** rafhiqulislam@yahoo.com

An organization is dealing with a major crisis and wants to inform its stakeholders about the reasons and remedies for the current crisis<sup>3</sup>. How can multiple factors be summarized in a single, clear statement? A multinational corporation wants to convey its brand values to an employee and show their relevance to operations. How can make tangible and clear to the entire staff? Communication touches every aspect of human activity. Business communication is any communication promotes a product, service or organization, with the objective of making sale. In business communication, messages are conveyed through various channels of Communication, including internet, print (publication+, radio, television, outdoor and word of mouth.

### **Objectives of the Study**

A. The main objective of this study is to analysis the effectiveness of skill and KISS principles of communication based on interpersonal activities.

B. Specific objectives are:

i. to investigate the impact of business communication on organizational performance in the organizations.

ii. to find out the usefulness of KISS principles in business.

iii. to explore the career destroying interpersonal blunders.

iv. to find out communication mistakes and provide suggestions for improving communication skills in business.

### **Rationale of the study**

An organization achieves success from effective business communication. Communication performs various activities to be competing with various competitors off the job and on the job. Now the question is what type of principles and skills are essential for successful communication. There are some prospects of communication application in the organization. There are limited studies in this area in Bangladesh. Therefore, the study has become an important issue to both researchers and the users willing to increase efficiency of the communication skills in business.

### **Methodology of the Study**

It is an empirical study. Basically this article has been prepared on secondary information. The major sources of information are various published journals, books, newspapers, magazines and websites.

The researchers faced few limitations because the information about principles and skills of business communication are not available.

### **Literature Review**

In the age of information everybody, we have to send, receive, and process huge numbers of messages every day. However, effective communication is about more than just exchanging information; it also about understands the emotion behind the information. Effective communication can improve relationships at home, work, and in social situations with improving teamwork, decision-making, and problem solving. Effective communication combines a set of

skills including nonverbal communication, attentive listening, the ability to manage stress in the moment, and the capacity to recognize and understand your own emotions and those of the person you are communicating with.<sup>4</sup>

Business communication is the sending and receiving of verbal and non-verbal messages within the organizational context. Hanna and Wilson (1998) expanded of this definition indicating business communication is a process of generating, transmitting, receiving, and interpreting messages in interpersonal, group, public and mass communication contexts through written and verbal formats. Hynes (2005) stated effective business communication is the key to planning, leading, organizing, and controlling the resources of the organizations to achieve objectives, and may be formal or informal in nature. Business communications functions include media relations, online communications, marketing, special events, product/brand communications, crisis management, employee/internal communications, community relations, and product/brand advertising<sup>5</sup>. It is widely accepted that business management and business educators perceive communication skills as highly valuable to employees and organizations alike. In business organizations, numerous sources have reported that communication skills are critical to career success and a significant contributor to organizational success.

One of the uniqueness of the human being is the ability to objectify their thoughts and ideas through language. With the social evolution of language, especially speech language, human was able to widen gap between them and the rest of the animal kingdom. Thus, language can be seen as a system of sounds, symbols and words for purposes of communication. Therefore, it may be stated that business communication may be beneficial for some businesses, while it may not be for others as a result of variations in the environment, practices, noise, contexts and cultures amongst others influencing factors. According to the management study guide (1998–2001), business communication involves constant flow of information. Feedback is an integral part of business communication. Now days, corporate business structures have been formed in these business organizations it has become difficult to manage, organize, direct and control the various levels of human resources without effective communication. Communication here plays a very important role in the process of directing and controlling the people in the organization. In this situation there should need effective communication between superiors and subordinates in the organization between organizations and the society, between management and trade unions etc. Communication is essential for the success and growth of an organization. Therefore, communication gaps should not allowed occurring in any organization.

Business communication encompasses a huge body of knowledge of internal and external communication. Internal communication includes communication of corporate vision, strategies, plans, corporate culture, shared values, and guiding principles, employee motivation, cross-pollination of ideas, etc. While external communication includes branding, marketing, advertising, selling, customer relations, public relations, media relations, business negotiations, etc. Whatever form it takes, the objective remain the same, i.e. to create a business value.

Furthermore, business communication can be of two types – oral communication, and written communication. An oral communication can be formal or informal. Generally, business communication is a formal means of communication. It includes meetings, conversation, counseling, conference, telephone, radio, television, interviews, group discussions, speeches, etc. An example of informal communication would be the grapevine. Written means of business communication includes agenda, reports, letters, circulars, memos, notices, minutes, telegrams, manuals, etc.

Every business aim is to gain profit and learn something from it. No businessperson desires to make losses as this may lead to non-sustainability and eventual close down/liquidation. According to Alyssa (2006), the ability to communicate, and communicate well is one of the biggest factors in business success. Effective communication is essential in the pitching potential clients; clients meeting; consumer service; face-to-face networking; and marketing your business.

Anderson and Bacon (2004) surveyed employers and found they consistently ranked communication skills, in particular writing ability, among the most important skills for undergraduate business students to possess. However, they found improving writing skills, especially with respect to punctuation, grammar, and word choice, often require substantial teacher, time and effort, which may be a rare resource considering the abundance of content that must be covered in most business courses. Regarding the other primary communication skill, oral communication, Maes, Weldy, and Ice ogle (19;7) found that oral communication was one of the top three competencies needed to succeed in a managerial position<sup>6</sup>. Yet other studies over decades demonstrated the unsatisfactory oral communication skills of recent graduates (Bolt-Lee & Foster, 2003). Thus, it appears that preparing students' oral communication skills for the managerial workplace has not been highly successful.

**Use of KISS Principles:** The basic principle of business communication is to keep our message short and simple. KISS stands for “*Keep It Short and Simple*”. Application of this principle means composing our business messages using short and simple words, sentences, and paragraphs. Our messages, as a result, will be concise, easy to understand, and straightforward. For examples-

- Short words : Words with fewer syllables.
- Simple words : Commonly used words, having usually one meaning.
- Short sentences : Sentences having fewer words.
- Simple sentences : Sentences having one independent clause.
- Short paragraphs : Paragraphs having fewer sentences.
- Simple paragraphs : Paragraphs having simple meanings.

The KISS principles may be implemented effectively if we follow the followings.

### **Choosing Words**

- Choose Understandable Words
  - Select simple words. (e.g. “spellbind” instead of “mesmerize”)
  - Use short words. (e.g. “copy” instead of “reproduction”)

- Use appropriate non-technical words. (e.g. “conference” instead of “symposium”)
- Use Concrete Words (e.g. “100 degrees Fahrenheit” instead of “hot”)
- Prefer Strong Words (e.g. “first” instead of “initial”)
- Emphasize Positive Words
- Avoid Overused Words
- Avoid Obsolete Words

## Developing Sentences

**Use Short Sentences:** Short sentences are less complex, easier, concise, clear, an efficient and to the point to understand.

**Prefer Active Voice in Sentences:** The active voice is more direct, stronger, and more vigorous than the passive voice.

**Give Sentences Appropriate Emphasis:** giving your sentences, appropriate emphasis means emphasizing the important ideas and de-emphasizing the unimportant ideas.

## Forming paragraphs

**Use Short Paragraphs:** A short paragraph is easy to understand, helps your receivers organize their thoughts more easily, and appears more inviting to the receiver.

**Give Paragraphs Unity:** Paragraph unity means that all the sentences in a paragraph relate to one topic.

**Organize Paragraphs Logically:** Paragraphs can be organized logically using one of two basic plans: the direct plan (deductive approach) or the indirect plan (inductive approach).

**Give Paragraphs Appropriate Emphasis:** We need to emphasize the important ideas and de-emphasize the unimportant ideas.

Thus, **Length:** Short paragraphs emphasize content and long paragraphs deemphasize content.

**Location:** Beginnings and endings of paragraphs are the locations of greatest emphasis. The middle of a paragraph is the location of least emphasis.

**Repetition:** Repeating key words throughout the paragraph can emphasize the ideas represented by those words.

**Explicitness:** You can tell your reader that an idea is important or unimportant.

**Format:** The way you arrange and punctuate a paragraph—set ideas off with punctuation, listings, wider margins, and so forth—can give emphasis to selected ideas.

**Mechanics:** You can emphasize ideas using mechanical means: underlining, boldface type, color, type size, typeface, uppercase letters, bullets, arrows, and circles.

## Blunders of Interpersonal communication

Here are eight interpersonal communication blunders that can destroy your career over time:

**Owning a weak handshake:** A weak handshake gives the signal of uncertainties, hesitation, lack of integrity, lack of confidence and lack of courage of communication. **Displaying a nervous giggle:** Just like a weak handshake. the nervous giggle in the eyes and mind of your audience, turns you into a child.

**Over-using "I'm sorry":** A 'killer' for undermining your authority, a phrase like, "I need your report on my desk by 5 o'clock, sorry" just knocks your

professionalism, your communication and your career for six. **Standing passively:** Crossed arms, crossed legs... they signal just one thing—detachment, as if you really don't want to be there, listening to the other person, but you *has* to. Passively standing kicks down the building bricks of trust, over time reducing your career reputation to rubble. **Avoiding eye contact:** By not looking at your audience (of one of one thousand) in the eye, you come across as nervous and insincere. **Playing with your hands:** Wringing your hands or playing 'fig leaf' is a way of conveying insecurity about yourself or your message. **Speaking too softly:** If eyes of others your speaking is too soft, they think you are not confident about yourself. **Using qualifying words:** Seriously, using words such as "kind of", "sort of" and "maybe" make even the smartest of us appear unsure.

**Effective Communication Improve Skills in Business and Relationships:** Effective communication helps us better understand a person or situation and enables us to resolve differences, build trust and respect, and create environments where creative ideas, problem solving, affection, and caring can flourish. As simple as communication seems, much of what we try to communicate to others—and what others try to communicate to us—gets misunderstood, which can cause conflict and frustration in personal and professional relationships. By learning these effective communication skills, we can better connect with our spouse, kids, friends, and co-workers<sup>7</sup>. The followings are some effective communication skills-

**Listening:** Successful listening means not just understanding the words or the information being communicated but also understanding how the speaker feels about what they are communicating. Effective listening can make the speaker feel heard and understood, create an environment where, everyone feels safe, save time, relieve negative emotions. Tips for effective listening are focused fully on the speaker; avoid interrupting; avoid seeming; judgmental; and show your interest

**Nonverbal communication:** When we communicate things that we care about, we do so mainly using nonverbal signals. Wordless communication, or body language, includes facial expressions, body movement and gestures, eye contact, posture, the tone of your voice, and even your muscle tension and breathing. The way you look, listen, move, and react to another person tell them more about how you're feeling than words alone ever can.<sup>8</sup> Tips for improving nonverbal communication is practice observing people; be aware of individual differences; look at nonverbal communication signals as a group; use nonverbal signals that match up with your words; adjust your nonverbal signals according to the context; and use body language to convey positive feelings.

**Managing stress:** In small doses, stress can help you perform under pressure. However, when stress becomes constant and overwhelming, it can hamper effective communication by disrupting your capacity to think clearly and creatively, and act appropriately. When you are stressed, you are more likely to misread other people, send confusing or off-putting nonverbal signals, and lapse into unhealthy automatic patterns of behavior. To deal with stress during communication: Recognize when you're becoming stressed; take a moment to calm down; bring your senses to the rescue; look for humor in the situation; be willing to compromise and agree to disagree



**Emotional awareness:** Emotional awareness provides you the tools needed for understanding both yourself and other people, and the real messages they are communicating to you. Although knowing your own feelings may seem simple, many people ignore or try to sedate strong emotions like anger, sadness, and fear. However, your ability to communicate depends on being connected to these feelings. If you are afraid of strong emotions or if you insist on communicating only on a rational level, it will impair your ability to fully understand others, creatively problem solve, resolve conflicts, or build an affectionate connection with someone.

Emotional awareness helps you to understand and empathize with what is really troubling other people; to understand yourself, including what is troubling you and what you really want; stay motivated to understand and empathize with the person you're interacting with, even if you don't like them or their message; communicate clearly and effectively, even when delivering negative messages and build strong, trusting, and rewarding relationships, think creatively, solve problems, and resolve conflicts

**Seven C's:** To establish good business communication, it helps to have a blueprint of the 7 C's of effective communication. Concise, Complete, Conversational, Considerate, Confidence, Check and Control are 7 C's. Success of the organization depends on effective business communication through the followings:

**Step 1:** Analyze your audience before you make a presentation or conduct a meeting.

**Step 2:** Give all the background necessary for people who receive your email, presentation or lecture to take action, such as make a decision based on the information you provide.

**Step 3:** Keep track of the questions people ask you and learn how to respond to common inquiries. **Step 4:** Choose the right communication format for each situation.

**Step 5:** Proofread your written communication, such as email, reports or other documents.

**Step 6:** Pay attention to body language when communicating in person.

**Step 7:** Defer judgment until the conversation concludes.

**Step 8:** Recognize cultural differences in communication styles.

**Other ways:** The other ways of success are ask questions, repeat what was said? Communicate your feelings and avoid strong reactions.

### **Writing Skills Essential to Business Success & Promotion**

**Writing and Grammar Skills:** Run any documents through a spelling and grammar checker to catch any mistakes you did not find. Brush up on common grammatical mistakes, such as writing "your" instead of "you're" or "it's" instead of "its."

**Presentation Skills:** Be concise. State what you can do for the other person and then respond to all questions, comments or concerns.

**Business Etiquette Knowledge:** The art of communication also extends to knowledge about common business etiquette.

### **Body language will make or break future leaders**

In the future, leaders who believe that what they say carries more weight than anything they do, will be asked to step down from that position -- or simply step down. The most successful

leaders will be those whose policies, actions, behaviors, and, yes, body language are strategically aligned with their verbal messages. From "The Silent Language of Leaders: How Body Language Can Help or Hurt How You Lead, here are three predictions that link the future of effective leadership with nonverbal communication: **Prediction: 1** - The visual technology revolution will make body language skills even more crucial than they are today. **Prediction: 2** - The body language of effective leaders will become increasingly “warm.” **Prediction: 3** – Authenticity will be increasingly revealed through body language.

### Top Ten Business Communication Mistakes

Communication is an essential part of getting things done. However in the age of emails and iPhones, communication mistakes are perhaps more likely to happen as ever before. Top ten business communications mistakes are: **One:** Failure to review; **Two:** Too many words; **Three:** Appropriateness; **Four:** Venue; **Five:** Failure to praise; **Six:** Criticism; **Seven:** Say it to the right person; **Eight:** Say what you mean, mean what you say; **Nine:** No answer is an answer; and **Ten:** Being closed off.

### Clear communication

The CLEAR formula Summarizing the different approaches and definitions found in previous research, we propose the following C-L-E-A-R formula to foster a clarity mindset in corporate communication.

Clarity element	Explanation
Contextualized	Give your messages a clear context. Tell people why the message is important and for whom it is important.
Logically structured	Give your messages an explicit, logical and consistent structure.
Essential	Focus on the key message. Avoid lengthy sentences or needless deviations.
Ambiguity-free	Avoid vague or unclear terms. Provide definitions when needed.
Resonating	Address your audiences directly with vivid examples to engage them. In social media, for example, ask for comments or responses.

### Findings and Recommendations

The major findings of this research are to provide knowledge regarding the effectiveness of business communication in every organization and its significance to performance<sup>15-17</sup>. The researchers recommend the following suggestions to improve business communications effectiveness.

1. Organizations should use the skills of communications to determine the extent to which organizations emphasize effective business performance.
2. Career damaging interpersonal communication blunders have been identified those can help both parties (sender and receiver) to error eliminating environment.

3. The business communication scales used in this research in conjunction with the associated results there from should enable corporate managers to identify their strategic strengths and weaknesses, and the relevant areas that need managerial attention.
4. This article has been focused the relative effectiveness of companies in achieving their goals and objectives via effective business communication depending on KISS principles.
5. It has been find out the trust and reliability problems among the interpersonal business organizations. The reliability of the sender and receiver message barriers of business communication should overcome through proper practices.
6. Managerial efficiency should develop by eliminating the language weakness and improve understanding in different organizational cultures.
7. These results may be useful to both academic and business practitioners with interest in the economy of any country.

### **Conclusion**

The study found that KISS principles and various skills of communication practice in the organizations can bring effectiveness of the business. It encourages parties, increases sales and turnover, reduces cost of production and meets the customer's satisfaction. It also helps to improve market share, personnel satisfaction, level of social responsibility, level of goods or services quality, level of sales volume, achievement of short- and long-term goals, satisfaction with company's business practices and finally 'satisfaction with overall company's performance in its business operations'. It has empirically examined the incidence of business communication practices using the adapted and modified business communication construct measures. It has been found that organizations generally emphasize effective business communication issues were related to the category of business (service versus manufacturing) and its size. To enhance the understanding of the practical application of business communication among the parties skills and KISS principles are needed.

### **References**

1. Lesikar, R.V. 1972, *Business Communication*, Homewood, IL: Irwin.
2. Dulek, R.E., & Lannon, J.M. 1990, *Business Communication* (3<sup>rd</sup> Ed.), Glenview, IL: Scott, Foresman.
3. Kotler, P. (2004), *Marketing Management*. New Delhi: Pearson Education.
4. Blalock, M. 2005. Listen up, Why Good Communication is Good Business, Wisconsin Business Alumni update.

5. Dulek, R.E., & Fielden, J.S. 1990, Principles of Business Communication, Newyork: MacMillan
6. Goldhaber, G.M., 1979 Organizational Communication (2<sup>nd</sup> Ed.), Dubuque, IA: Willium C. Brown.
7. Azmir, Rofiqul and Nazma, 2011, HRM Practices in the Business: Need for Achieve Goal, Dhaka International University Journal, Volume-3, No.-1, and December 2011.
8. Williams, F.W. 1984, the New Communication, Belmont, CA: Wadsworth.
9. WWW.Google.Com

# An Overview on Problems and Prospects of Training in Banking Sector of Bangladesh

**Md. Azmir Hossain\***

**Abstract:** The study is an attempt to investigate and analyze the problems and prospects of training and its importance in the banking sector of Bangladesh. The research searches for to evaluate existing literature reviews of training needs assessment and recommends several suggestions for the improvement of it's so that to meet the employees' and organizational needs in the banking sector of Bangladesh. The findings addressed that the training is prerequisite for an effective plan of success that helps for organizational growth and development. The data of this study was collected via practical survey, email and over telephone interview of 100 respondents of 10 private banks of Bangladesh which analyzed and presented in terms of charts and graphs. Consequently the recommendations support for the noteworthy of prospects of training which will bring a constructive worth in this sector of Bangladesh and in overseas.

**Key Words:** Training and development, Banking sector, Employee, TNA, Prospects, Problems.

## **Introduction**

The banking history of Bangladesh is more than half a century old in modern sense and has been playing a very significant role in the economic development of the country. At present there are four state own banks, five specialized banks, nine private foreign banks, thirty one private commercial banks and eight Islamic banks are operating in the country (Bangladesh Bank Report, 2013). In 1984, the Government of the Peoples Republic of Bangladesh established training and development policy by formulating National Training Council in 1983. The main aim of the National Training Council is to provide formal training for Government Officials. In the past, a sizable segment of the Bangladesh economy was devoted to the manufacture and sale of goods. Employees needed to know how to produce things. However, over the years, the service sector has experienced increasing growth. This has influenced the knowledge, skills and abilities (KSA) demands of employees. Employees in today's service economy are required to interact with people, work in teams, be responsive to customers, have an orientation for quality and deliver services quickly. Furthermore, as the prevailing philosophy of management moves towards more employee involvement and less hierarchical organizational structures, employees are being asked to take on more responsibility and accountability for their work. The changes previously mentioned have precipitated downsizings, rightsizings, restructurings and reorganizations that have resulted in a large number of displaced workers. These changes have sparked interest in alternative work arrangements. Moreover, employees are seeking the flexibility of job sharing, telecommuting and temporary work arrangements. Each of these factors has led to increased needs for training of the workforce.<sup>1</sup>

The study was prepared upon the previous training literatures by providing a detailed examination of training needs assessment, importance, evaluation practices, and comparing those practices with perceived levels of training program success and organizational effectiveness. The question of the amount of learning of training and the effect of training is answered through evaluation process. With increasing expenditures on training, yet scarce resources, comes a greater need to evaluate the success or failure of training programs. Therefore, the purpose of training need assessment is to add

---

\* Assistant Professor, Department of Business Administration, Faculty of Business Studies, Dhaka International University, Dhaka, Bangladesh

**Correspondence to:** Md. Azmir Hossain, E-mail: [azmirdu@gmail.com](mailto:azmirdu@gmail.com) (01915-352491)

value to an organization. Hence, evaluation measures the progress in achieving this goal by purposefully improving training programs and measuring their worth. The evaluation model and the training program are established by the needs assessment of training. A thorough needs assessment leads to effective and efficient training, which increases the likelihood that evaluation will demonstrate successful value added outcomes.<sup>2</sup>

Thus, the need for basic skills training, continuing training and retraining is ever present. The importance of employee training is also evident in the amount of money spent on training and development in organizations. Berger (2000) states the expenditure on human resource is imperatively high rising. Given the role of training as a business strategy it is important that any training effort be targeted and relevant. Thus, the process by which training needs are identified and addressed becomes a critical issue for organizations. It will introduce basic needs assessment terminology and discuss potential options for the process. In addition, the research will focus on emphasizing new developments and trends in the application of training needs assessment. The study further will review the literature pertaining to the identification of employee training needs and conclude by proposing a set of recommendations about the importance of training to facilitate organizations in the Banking sector of Bangladesh and overseas.<sup>3</sup>

### **Objectives of the Study**

This study is an attempt to see if assessment and evaluation needs really matter to training success through following objectives.

**A. General Objective:** To analyze the problems and prospects of training in the banking sector of Bangladesh.

**B. Specific Objectives:** The specific objectives are:

- a) To explore the importance of training needs assessment in the banking sector of Bangladesh.
- b) To evaluate the importance of training.
- c) To investigate the effectiveness of training practices at banking sector through employee survey.
- d) To identify the weakness in training practices of selected private commercial banks in Bangladesh.
- e) To recommend several suggestions for solving training problems in the banking sector of Bangladesh.

### **Scope of the Study**

This research covers the training system of banking sector of Bangladesh, along with some recommendations to improve the training policies and practices. In addition to the above training programs, banks also offer specific customized training programs. Banks have partners in all organizations and training can bring in expert employees to make sure that get the best results.

### **Rationale of the Study**

An organization takes services from training division. Training performs various activities such as planning, performing, producing, processing, servicing and improving skills. Training is not a general function of HRM in the banking sector. Banks face various problems when they intend to be competing with various countries of the world from Bangladesh. On the other hand there are some prospects of training of the executives and officers of the banks. In the last two decades training of the sectors has increased to a greater extent. There are limited studies in the area of Problem and Prospects of training in the banking sector of Bangladesh. Therefore, the study has become an

important issue to both the researchers and the bankers willing to increase efficiency of the employees in Bangladesh.

## Literature Review

The banking sector of Bangladesh is playing a significant role and playing as a leader in the financial, industrial and commercial activities. Debnath (2003) indicates that productivity of manpower in the banking sector of Bangladesh will have to be increased by proper training both on the job and off the job. Moreover, Decenzo & Robins (2003) state “training brings about the changes in ability, awareness, approach and behavior”. Besides, Griffin (2003) supports training usually in human resources management perspective refers to teaching operational and technical employees as to how to do the job for which they were hired. Furthermore, Mathis & Jackson (2004) state ‘training as a procedure whereby people obtain capabilities to assist in the accomplishment of organizational objectives.’<sup>4</sup> Besides, McGehee and Thayer (1999) support training as, “the formal procedures a company uses to facilitate employees’ learning so that their resultant behavior contributes to attainment of the company’s goals and objectives”. More specifically, training is a systematic approach to skills and knowledge acquisition or attitudinal enhancement that improves performance (Goldstein, 2001). Therefore, Rothwell, (2002) indicates effective training as systematically designed learning, based on a complete analysis of job requirements and trainee compatibility. This clarification implies a definite training process, one highly regarded model for describing the systematic development of training programs is the instruction design process. This model states that there should be a logical flow in training practice moving from planning to implementation to evaluation.<sup>5</sup>

Training is the acquisition of knowledge, skills, and competencies as a result of the teaching of vocational or practical skills and knowledge that relate to specific useful competencies. Training has specific goals of improving one's capability, capacity, and performance. It forms the core of apprenticeships and provides the backbone of content at institutes of technology.<sup>6</sup> In addition to the basic training required for a trade, occupation or profession, observers of the labor-market recognize the need to continue training beyond initial qualifications: to maintain, upgrade and update skills throughout working life. People within many professions and occupations may refer to this sort of training as professional development. The instructional design process revolves around three basic steps: needs assessment, training design and training evaluation.<sup>7</sup>

Training needs assessment is traditionally regarded as a diagnostic process that occurs before training. The purpose of formal needs assessment is to identify the training targets (Kozlowski & Salas, 2003). In the past, there has been disagreement about the appropriate terminology to describe this process. Some authors choose to distinguish needs assessment from needs analysis. For example, Kaufman and Valentine (1999) refer to needs assessment as the process for identifying and prioritizing gaps in performance. In contrast, they define needs analysis as the process for attributing cause to identify performance gaps. Hence, the entire process will be referred as needs assessment. So, once training has been conducted, a comprehensive evaluation should follow.<sup>8</sup>

The primary purposes of training evaluation are to examine the viability, success rate and utility of implemented training programs. Without this information, no clear conclusions about the effectiveness of programs can be made.<sup>9</sup> Nor can organizations make informed decisions regarding where to make revisions or updates to current programs (Robbins and Coulter, 2005). Although the terms training evaluation and effectiveness are sometimes used interchangeably, several authors have noted subtle differences between the two (Kraiger et al. 2003). Hence, training effectiveness is a

broad construct that identifies situational or contextual factors impacting learning, retention and transfer.<sup>10</sup> This focus is critical for uncovering whether a training program was effective or ineffective due to characteristics of the program or to factors outside the control of the training system (Ford, 2006).

Training evaluation is concerned with the achievement of a desired level of proficiency and the attainment of requisite knowledge and skills. Therefore, training evaluation is a two-fold process that involves establishing indicators of learning or training transfer and determining exactly what job related changes have occurred as a result of training (Goldstein, 2001). Moreover, the most widely-used evaluation model was developed and revised by Kirkpatrick (1994). In this model, training may be evaluated at four different levels. Level One evaluation centers around the general affective reaction participants have to the program. Level Two evaluations focuses on demonstrated mastery of concepts in training.<sup>11</sup> Level Three evaluations go a bit further and focus on a demonstrated behavior change on the job. At Level Four training is assessed by whether or not it impacts organizational results. In recent years, this taxonomy has been expanded to include additional evaluative criteria such as return on investment (ROI) and cost/utility analyses (Phillips, 2002).<sup>12</sup>

Therefore, the choice of the most appropriate level of evaluation is related to the ultimate goals of the training and evaluation efforts. For example, in some instances, it may be sufficient to only determine if trainees actually acquired knowledge and skill during the training intervention. The more likely scenario is one in which the organization would like to determine if what has been learned in training is actually used on the job.<sup>13</sup> Hence, it is clear that the training function for most organizations is not as effective or efficient as it could be. To truly be effective or successful, training programs must incorporate more of the established best practices. All of the steps in the process are important (Tyson, 2006). However, Goldstein (2001) claims that, of all of the best practices, needs assessment is probably the most important part of the process.<sup>14</sup> Therefore, training needs assessment is the foundation of the entire instructional design process. It establishes the content of subsequent training. If not done correctly, or at all, the job-relatedness, effectiveness and validity of any training program is jeopardized. In addition, needs assessment provides a database to support or justify resource allocation for other human resource functions.<sup>15</sup>

**Reasons of employee training and development:** Most common reason for Training and Development are Professional Development Plan or Performance Appraisal. Others reasons are to help guide and prepare the business for a new technology or tool, to prepare an employee for a new role – this could be a promotion or a sideways transition and to help the business with certification.

**Benefits of training in banking sector:** As mentioned throughout the course of this article, the benefits of continuous and ongoing training are in significant level. Benefits are to increase job satisfaction and morale, to improve customer satisfaction, to increase employee motivation, increase efficiencies in processes, to increase knowledge of new technologies and methods, improve employee retention and to increase in productivity.

**Types of training:** The following are the types of training in Bangladesh.<sup>16</sup>

**Physical training-** Physical training concentrates on mechanistic goals: training-programs in this area develop specific skills or muscles, often with a view to peaking at a particular time. Some physical training programs focus on raising overall physical fitness.



**Job training and development-** Some commentators use a similar term for workplace learning to improve performance: training and development. There are also additional services available online for those who wish to receive training above and beyond that which is offered by their employers. Some examples of these services include career counseling, skill assessment, and supportive services. One can generally categorize such training as *on-the-job or off-the-job*.

On-the-job training takes place in a normal working situation, using the actual tools, equipment, documents or materials that trainees will use when fully trained. On-the-job training has a general reputation as most effective for vocational work. Off-the-job training takes place away from normal work situations — implying that the employee does not count as a directly productive worker while such training takes place. Off-the-job training has the advantage that it allows people to get away from work and concentrate more thoroughly on the training itself. This type of training has proven more effective in inculcating concepts and ideas. A more recent development in job training is the On the Job Training Plan or OJT Plan. According to the United States Department of the Interior, a proper OJT plan should include: An overview of the subjects to be covered, the number of hours the training is expected to take, an estimated completion date, and a method by which the training will be evaluated.<sup>17</sup>

**Religion and spirituality:** In religious and spiritual use, training may refer to the purification of the mind, heart, understanding and actions to obtain a variety of spiritual goals such as (for example) closeness to God or freedom from suffering. Note for example the institutionalized spiritual training of Threefold Training in Buddhism, Meditation in Hinduism or discipleship in Christianity.

Generally training is split into two very broad categories – **Internal** (provided by the company and utilizing existing internal resources and tools) and **External** (paid for by the company but provided off site through a 3rd party training firm). Most often External training is utilized when the skills are not already present in the organization and/or it is a senior level course requiring specialist knowledge and certification. In addition, External Training might be utilized if there is an urgent need for a specific skill set in the business. Both types of training have value however and the reasons for choosing one type over another are somewhat dependent upon budget and time. To ensure that your employees are performing at their peak (especially those in more senior roles) there is a constant need for training and development as ensuring that your staff are gaining this skill provides big payoffs to the employer in many different areas.

**The training simulation in banking sector:** A training simulation is a virtual medium through which various types of skills can be acquired. Training simulations can be used in a wide variety of genres; however they are most commonly used in corporate situations to improve business awareness and management skills. They are also common in academic environments as an integrated part of a business or management course. The word simulation implies an imitation of a real-life process, usually via a computer or other technological device, in order to provide a lifelike experience. It is important to emphasize that training simulations are not just games; their aim is to educate and inform in an exciting and memorable way, rather than purely to entertain.<sup>18</sup>

**Importance of training in banking sector:** Ensuring that your team is motivated and eager to do the job is absolutely important, however ensuring that they have the right and relevant skills to do it well is perhaps even more so. Training and Development when provided by the organization ensures that your employees are developing the relevant skills for your organization and not just gaining “book knowledge” that might, or might not be useful to you and your company.<sup>19</sup> It is important to realize

that employees want to be valuable to the company that they work in and they also want to ensure that their skills are competitive in their industry.<sup>20</sup> While the latter might be something that really only applies to their CV – it is still something that should always be considered, especially in today’s economy. However, by ensuring that your employees develop career enhancing skills it demonstrates to them their worth to the business and makes overall employee retention significantly easier, not to mention employee motivation.<sup>21</sup>

**Topics of training:** While some technical courses are very specific to the technology that is being trained, there are some commonalities in training that should be made clear as many courses will emphasize these areas quite extensively.

**Communication skills-** Being able to speak to your peers, supervisors and staff in the correct tone and with the correct language is more important today than it ever was. With the increasing diversity in today’s workforce it is increasingly easier to make an incorrect assumption about what is right and what is wrong.

**Basic IT skills-** Regardless of the role and position, all “white collar” jobs require a certain level of competence with regards to IT skills. Generally speaking the more conversant you are with a keyboard and mouse, the faster and better you will be in your role and while most positions do not require you to know how to troubleshoot complex computer problems, having a basic understanding is absolutely essential.

**Customer service-** Businesses compete in all sectors and markets and one of the key differentiators for the “good” companies is the level of Customer Service that they are able to provide to their clients. Customer Service is harder to train (in comparison to IT Skills for example) but it can be trained and all businesses should ensure that they are continually enforcing the value of this into their teams.

## **Methodology of the Study**

This paper has been prepared relying on both primary and secondary data. Primary data has been obtained through a sample survey via face-to-face, telephone interview and email questionnaires to 100 respondents of 10 private banks of Bangladesh. Besides, structure and semi-structure interviews were conducted with the concerned personnel of banks by over telephone. The participants were the Executive Officer, Senior Executive Officer and Officer of different private commercial banks of Bangladesh. The convenience sampling method is used which involves the selection of a group from the population on the basis of available information thought.

## **Sampling (Population)**

The convenience sampling is used in this study because knowledge of the researcher can be best used in this technique of sampling and this technique of sampling is also economical. The design of the questionnaire involves a combination both open and close ended questionnaires. To conduct this research study 10 banks have been selected from the total commercial banks in Bangladesh. These banks are Arab Bangladesh Bank Limited, Dutch Bangla Bank Limited, Southeast Bank Limited, Export Import Bank Limited, One Bank Limited, Islami Bank Bangladesh Limited, First Security Islami Bank Limited, The City Bank Limited, Jamuna Bank Limited and National Bank Limited. In this research, out of 100, 88 employee’s responses properly, the response rate is 88 percent. The questionnaire consists of different questions on nine training dimensions such as Management’s

Support on Training, Input from Employee about Trainings, Skill & Knowledge Suited Programs, Management's Assurance on Training Needs, Training Related to Organizational & Personal Goals, Fairness in the Approval of Training Program, Content & Frequency of training, Information on Training Programs and Training Increases Competitiveness.

The questionnaire was developed by using a five point Likert scale, whereas- 1 = dissatisfied, 2 = somehow satisfied, 3 = satisfied, 4 = moderately satisfied, 5 = highly satisfied. But some secondary data have been used in the study. The secondary sources of information were various publications of Bangladesh Bank, journals, books, newspapers, magazines and websites etc. In this study, some statistical measures such as Z-test mean and proportion analysis is used to examine employee's satisfaction on training. The data was analyzed by applying statistical formulae which are graphically presented through charts, tables and image etc.

### **Hypothesis Development**

On the basis of HRM practices, the following hypotheses are developed:-

- H1: Employees' satisfaction on "Management's Support on Training".
- H2: Employees' satisfaction on "Input from Employee about Trainings".
- H3: Employees' satisfaction on "Skill & Knowledge Suited Programs of training".
- H4: Employees' satisfaction on "Management's Assurance on Training Needs".
- H5: Employees' satisfaction on "Training Related to Organizational & Personal Goals".
- H6: Employees' satisfaction on "Fairness in the Approval of Training Program".
- H7: Employees' satisfaction on "Content & Frequency of training".
- H8: Employees' satisfaction on "Information on Training Programs".
- H9: Employees' satisfaction on "Training Increases Competitiveness".

### **Data Analysis & Results**

#### **A. Employee satisfaction survey**

H1: Employees' satisfaction on Management's Support on Training

It is assumed from the hypothesis that employees are satisfied on the current Management's Support on Training of their organizations. H1 shows that at 0.05 level of significance (two tailed test), table value (1.96) is greater than calculated value ( $Z = 0.55$ ). So, the null hypothesis is accepted and hence, we conclude that employees are satisfied on Management's Support on Training selection systems of their bank.

H2: Employees' satisfaction on Input from Employee about Trainings

This hypothesis indicates that employees are satisfied with Input from Employee about Trainings. H2 shows that at 0.05 level of significance (two tailed test), table value (1.96) is less than calculated value ( $Z = 8.82$ ). So, the null hypothesis is rejected and hence, we conclude that employees are not satisfied on Input from Employee about Trainings.

H3: Employees' satisfaction on Skill & Knowledge Suited Programs

It is assumed from this hypothesis that employees are satisfied with Skill & Knowledge Suited Programs. H3 shows that at 0.05 level of significance (two tailed test), table value (1.96) is greater than calculated value ( $Z = 0.25$ ). So, the null hypothesis is accepted and hence, we conclude that employees are satisfied on Skill & Knowledge Suited Programs.

#### H4: Employees' satisfaction on Management's Assurance on Training Needs

This hypothesis indicates that employees are enjoying enough Management's Assurance on Training Needs. H4 shows that at 0.05 level of significance (two tailed test), table value (1.96) is less than calculated value ( $Z = 8.7$ ). So, the null hypothesis is rejected and hence, we conclude that employees are not satisfied on Management's Assurance on Training Needs of their organizations.

#### H5: Employees' satisfaction on Training Related to Organizational & Personal Goals

This hypothesis indicates that Training Related to Organizational & Personal Goals is available in their organizations and employees are satisfied on that program. H5 shows that at 0.05 level of significance (two tailed test), table value (1.96) is less than calculated value ( $Z = 6.36$ ). So, the null hypothesis is rejected and hence, we conclude that employees are not satisfied on Training Related to Organizational & Personal Goals of their organizations.

#### H6: Employees' satisfaction on Fairness in the Approval of Training Program

This hypothesis indicates that Fairness in the Approval of Training Program is very flexible for employees and they involved with the managerial decision making. H6 shows that at 0.05 level of significance (two tailed test), table value (1.96) is less than calculated value ( $Z = 4.64$ ). So, the null hypothesis is rejected and hence, we conclude that employees are not satisfied on Fairness in the Approval of Training Program of their organizations.

**Table 1:** Levels of Satisfaction of Training dimensions

	MST 1	IET 2	SKP 3	MAT4	TRG 5	FAT 6	CFT 7	ITP 8	TIC 9
1 = Dissatisfied	7.95	32.95	9.09	30.68	22.73	13.64	11.36	31.82	9.09
2 = Somehow Satisfied	17.05	40.91	19.32	37.5	42.05	45.45	43.18	38.64	22.73
3 = Satisfied	43.18	19.32	39.77	22.73	22.73	25	29.55	20.45	36.36
4 = Moderately Satisfied	25	3.41	22.73	6.82	7.95	10.23	11.36	5.68	20.45
5 = Highly Satisfied	6.82	3.41	9.09	2.27	4.55	5.68	4.55	3.41	11.36
Totals	100	100	100	100	100	100	100	100	100

#### H7: Employee Satisfaction on Content & Frequency of training

The hypothesis indicates that Employee Satisfaction on Content & Frequency are easily performed their task. Employees receive fair treatment, recognition and overall quality supervision from boss. Table 1 shows that at 0.05 level of significance (two tailed test), table value (1.96) is less than calculated value ( $Z = 4.18$ ). So, the null hypothesis is rejected and hence, we conclude that employees are not satisfied on Employee Satisfaction on Content & Frequency of their organizations.

#### H8: Employees' satisfaction on Information on Training Programs

The hypothesis indicates that Information on Training Programs is present in their organizations; employees are satisfied on that system. Table 1 shows that at 0.05 level of significance (two tailed test), table value (1.96) is less than calculated value ( $Z = 8.18$ ). So, the null hypothesis is rejected and hence, we conclude that employees are not satisfied on Information on Training Programs of their organizations.

#### H9: Employees' satisfaction on Training Increases Competitiveness

This hypothesis indicates that Training Increases Competitiveness is very conducive for satisfaction at large. Table 1 shows that at 0.05 level of significance (two tailed test), table value (1.96) is greater than calculated value ( $Z = 0.17$ ). So, the null hypothesis is accepted and hence, we conclude that employees are satisfied on Training Increases Competitiveness of their organizations.

Therefore, it is clear that all dimensions are not equally satisfied to employees. It is also very clear from the Table 2 which dimensions highly satisfied or dissatisfied to employees.

Here, in table-1, MST=Management's Support on Training, IET=Input from Employee about Trainings, SKP=Skill & Knowledge Suited Programs, MAT=Management's Assurance on Training Needs, TRG=Training Related to Organizational & Personal Goals, FAT=Fairness in the Approval of Training Program, CFT=Content & Frequency of training, ITP=Information on Training Programs and TIC=Training Increases Competitiveness. Therefore, the analysis shows that employees are not fully satisfied on any Training dimensions of their organizations. So, the training dimensions quality should be improved for the betterment of the organization's success

**B. Telephone Interview:** In the telephone interview with HR executives of the banks researchers found several factors associated with training are discussed.

**1. Banks training effort-** Banks training includes required skills and knowledge the employee needs to efficiently conduct their tasks. Training at the banks also helps their employees gaining problem solving skills which helps them dealing with challenges under pressure.

**2. Training need assessment practices-** Banks key need assessment method includes archival, work sample, test, and performance based assessment methods. The work sample is mainly focused on banks everyday task description. For instance it aims at identifying employees' weakness at their regular task. The practice of testing is not conducted in general aspect.

**3. Levels of training analysis-** The banks conduct formal organizational and operational analysis for carrying out effective TNA. For instance, due to the nature and tasks of the organization, majority of the training is focused on finance, IT and customer services. However, there is no formal process of individual analysis in the organization. Most of the department heads informally address the training needs of the individuals.

**4. Training evaluation-** The banks use a three step process for training evaluations. The first step includes performance indicators such as trainee qualifications, instructor abilities, instructional materials, facilities, and training expenditures. Second step is mainly concerned with the value-adding activities of planning, design, development, and delivery of training. In the final stage, the evaluation of trainee reactions, knowledge and skills gained, improved job performance are measured in terms of profits, customer satisfaction, productivity.

**5. Evaluation of employee satisfaction-** No formal initiatives are taken in order to measure employee satisfaction. Training efforts have found to be significantly influenced the overall productivity of the organization. Even competing with international institution such as HSBC, Bank of She-long and Standard Chartered Bank, our local banks are still rated one of top financial institutions in the country. Key reason for such success is identified to be the ability to operate large amount of branches in the private sector and reach out to fulfill the needs of general population of the country through effective training.

**6. Influential factors for utilizing training-** The key contextual factors in Bangladesh are organizational and political environment followed by uncertain stock market in the finance industry. Also political disturbance has found to be unavoidable. Thus banks training are structured in such ways so that the workforce can gain the competences to handle pressure.

## **Discussion and Evaluation**

**1. Training Practices in the banking sector:** The result suggests that at the banking sector, three key training methods are used. These methods are archival, work sample and performance based assessment. The archival based assessment is formulated through overall organizational infrastructure and strategy. Work sample based assessment derived from everyday tasks. It is need to be noted that in terms of contextual analysis banks management does not conduct a formal person analysis. In addition, yearly performance based assessment is also conducted claimed by the officials of different banks.

**2. Level of analysis:** The result from study confirmed that at banking sector, formal organizational and task analysis are carried out by the management. In terms of individual analysis, no formal procedures are evident. Generally individual analyses are processed through department managers casually.

**3. Contextual factors for training:** From the managerial discussion, it has been found that only organizational context and political forces are the key influencers of banks training practices. The result suggests that banks key strategy for training mainly focused on the workforces' ability to handle pressure. The result from employee survey indicated that the organizational environment is supportive for training.

**4. Relationship between training & competitive advantage:** In the literature, several authors (Schneier et al, 1998; Goldstein, 2001; Armstrong, 2010) suggested that effective TNA practices can enhance the competitiveness of the workforce. The result from the study also corresponds with the literature as the management claimed training efforts have significantly increased productivity of the organization. It has been found that banks training facilitated the employees' skills level to effectively perform on the job.

**5. Relationship between training need assessment & evaluation:** In terms of relationship between need assessment and evaluation practices, the literature suggested one of the relationships involves training or organizational goals or both, as determined by the needs assessment and represented in the evaluation criteria-criterion relevance (Goldstein, 2001).

**6. Effectiveness of training practices:** In evaluating effectiveness of training practices at banking sector, it has been found that the organizational environment is supportive for employee training activities. Offered training programs are significantly skill and knowledge suited and the managers are also cooperative in ensuring employees' regarding the providence of the training they need. In addition the programs are relevant to organizational and personal objectives of the individuals.

## **Limitations of the Study**

The researchers faced few limitations because the information of that bank has a great confidentiality as a result the participants ignore to disclose some information. Therefore, the researcher decided to maintain confidentiality in the data analysis section. To the best of knowledge of the research very

little study was conducted on this specific area, that's why there is lack of guidance. This study was based on prospects and problems of training in the banking sector, so information was designed on the basis of Training dimensions only.

### **Findings and Recommendations**

The banking sector of Bangladesh is well known as a principal financier of the country and playing key role by contributing in the national economy. Banks play key role for the economy of the country as a member of financial institution. However, several lack of importance is still found of training in this area.<sup>20-23</sup> Therefore, in order to accelerate the success of this area, the following lines of actions is suggested:

- 1) It would be beneficial to the overall development of employees in the banking sector of Bangladesh if both the public and private banks in Bangladesh establish their own training institute where modern training methods such as online training, overseas training and digital training program would follow for employees training and giving importance of needs assessment before training programs.
- 2) It would be imperative to maintain an organized training staff that is capable of performing all training functions including needs assessment analysis and evaluation.
- 3) Some bank is still found informal training need assessment procedure. It is important to involve most of the training staff in needs assessment and evaluation procedure.
- 4) It would be most beneficial to adopt the same organizational strategy, structure and context, and be as close to the ideal of each as feasible and fruitful.
- 5) If the organizational effectiveness focus is on cost, banks should allocate a significant percentage of training budgets to needs assessment; possibly take the performance improvement philosophy of training.
- 6) The feedback analysis of employees training would be compared with need assessment analysis and its importance basis.
- 7) The effective cost -benefit analysis from this training program would put across the organization more accountable. As a result it would convey a long- term positive outcomes for the improvement of training program.
- 8) The authority of both public and private banks in Bangladesh would evaluate the training needs assessment in the banking sector with developed countries on a regular basis.

### **Conclusion**

The aspire of this research is to build upon the previous training literature by providing a detailed examination of needs assessment, its importance, evaluation practices, and comparing those practices with perceived levels of training program success and organizational effectiveness. The researchers found that most of the banks in Bangladesh have their own training institute, management attitude is very positive for training support and budget, incentives are given for trainees, and overseas training opportunity. However, there is a lack of needs assessment before training. The most important finding is that all the banks are not giving more importance for training. Therefore, the researchers proposed urgently adjustment of training that is followed by world top most banks that will bring a positive change in the banking sector in Bangladesh.

### **References**

1. Ferdous T & Razzak B.M 2012., Importance of Training Needs Assessment in the Banking Sector of Bangladesh: A Case Study on National Bank Limited (NBL), International Journal of Business and Management Vol. 7, No. 10.

2. Armstrong, M 2007, Human resource management (2nd ed.). London: Kogan Page Limited.
3. McGehee, M., & Thayer, P. W. 1999, Training in business and industry. New York: John Wiley & Sons.
4. Debnath, R. M. 2003, Bank and legal environment (1st Ed.). Dhaka: Nabajuga Prokashani.
5. Rahman, A. 2009, Bangladesh's Banking Sector-My Vision for the Future. Retrieved from <http://www.bangladesh-bank.org/mediaroom/speech/speech-britishbusinessgroup.pdf>
6. Ford, J. K. 2006, Advances in training research: An historical perspective, improving training effectiveness in work organizations (pp. 1-16). Mahwah, NJ: Lawrence Erlbaum Associates.
7. Robbins, S. P., & Coulter, M. 2005, Management (8th ed.). Upper Saddle River, New Jersey: Pearson. Education Inc.
8. Azmir & Rofiq 2012, Employee Satisfaction and HRM Practices in the Business: A Case Study on the Private Financial Service Sector in Bangladesh, Dhaka International University journal, Volume-05, No.-01, June-2013
9. Goldstein, I. L 2001, Training in organizations: Needs assessment, development, and evaluation. (3rd ed.). Pacific Grove, CA: Brooks/Cole.
10. Rahman, M.A. 1991, Assessment of Management training needs in the Commercial Banks of Bangladesh: A Micro Study, Journal of Business Studies, Dhaka University, Volume- XII, and No. 2.
11. Kaufman, R., & Valentine, G. 1999, Relating needs assessment and needs analysis. Performance and Instruction, 28(10), 10-14. <http://dx.doi.org/10.1002/pfi.4170281005>
12. Berger, S. 2000, Training shouldn't be the first to go. Modem Healthcare, 30 (8), and 35.
13. Mathis, R. L., & Jackson, J. H. 2004, Human resource management (10th ed.). Mason: South-Western.
14. Phillips, J. J. 2002, Evaluating corporate training: Models and issues. Boston, MA: Kluwer Academic Publishers.
15. Rahman, M.A. 2012, Human Resource Management Practices in Bangladesh, Zahin Publications, Dhaka.
16. Griffin, R. W. 2003, Management (5th ed.). New York: Houghton Mifflin Company.
17. Kirkpatrick, D. L. 1994, Evaluating training programs: The four levels. San Francisco: Berrett-Koehler Publishers.
18. Azmir, Rofiq & Nazma 2012, Economic Growth of Bangladesh and Readymade Garments Sector: A Case Study on RMG of Narayangonj, Dhaka International University journal, Volume-04, No.-01, July-2012
19. Rothwell, W. J. 2002, Beyond training and development: State-of-the-art strategies for enhancing performance. New York: AMACOM.
20. Schneier, C. E., Guthrie, J. P., & Olian, J. D. 1988, A practical approach to conducting and using the training needs assessment. Public Personnel Management, 17 (2), 191-205.
21. Ahmed, Jashim Uddin 2005, Human Resource Management Practices: A Case Study of the Supply Chain Department of Square Pharmaceuticals Ltd., Sri Lankan Journal of Management, Volume 10 Numbers 3 & 4, July - December, 2005.
22. Websites of Different Private Banks.
23. WWW.Google.Com



# The $(G'/G)$ -expansion method for exact traveling wave solutions of second order non linear differential equation

**Md. Anisur Rahman Pramanik**

**Abstract:** In this paper, we construct the exact traveling wave solutions of the second order non linear differential equation  $y'' + [2ay + f(x)]y' + af(x)y^2 = g(x)$  by means of the  $(G'/G)$ -expansion method, where  $G$  satisfies a second order linear ordinary differential equation  $G'' + \lambda G' + \mu G = 0$ . The proposed method is direct, concise, elementary, and can be used for solving higher order nonlinear equations.

**Keywords:**  $(G'/G)$ -expansion method, exact traveling wave solutions, nonlinear equations, solitary wave solution.

## Introduction

The investigation of the traveling wave solutions of nonlinear partial differential equations (NPDEs) plays an important role in the study of nonlinear physical phenomena. In recent years, new exact solutions may help to find new phenomena. The exact solutions have been investigated by many authors who are interested in nonlinear physical phenomena. Several direct methods for finding the explicit traveling wave solutions to nonlinear partial differential equations (NPLEs) have been proposed, such as the tanh-function method<sup>1</sup>, the exp-function method<sup>2</sup>, the jacobi elliptic function expansion method<sup>3</sup>, the homogeneous balance method<sup>4-5</sup>, the variational iteration method<sup>6</sup> and so on. More recently, a new method which is called the  $(G'/G)$ -expansion method<sup>7-8</sup> has been proposed to construct more explicit traveling wave solutions. In this paper, we use the  $(G'/G)$ -expansion method to solve the equation  $y'' + [2ay + f(x)]y' + af(x)y^2 = g(x)$ .

## $\left(\frac{G'}{G}\right)$ -Expansion Method Analysis

Suppose that a nonlinear equation, say in two independent variables  $x$  and  $t$  is given by

$$P(u, u_t, u_x, u_{tt}, u_{xt}, u_{xx}, \dots) = 0, \quad (1)$$

where  $u = u(x, t)$  is an unknown function,  $P$  is a polynomial in  $u = u(x, t)$  and its various partial derivatives, in which the highest order derivatives and nonlinear terms are involved. In the following, the main steps of the  $\left(\frac{G'}{G}\right)$ -expansion method are given:

**Step 1.** The traveling wave variable  $u(x, t) = u(z)$  where,  $z = x - Vt$ , permits us reducing Eq.(1) to an ODE for  $u = u(z)$  in the form

$$P(u, -Vu', u', V^2u'', -Vu'', u'', \dots) = 0, \quad (2)$$

**Step 2.** Let us suppose that the solution of ODE (2) can be expressed by a polynomial in  $\left(\frac{G'}{G}\right)$  as follows:

$$u(z) = \sum_{i=0}^m \alpha_i \left(\frac{G'}{G}\right)^i, \quad \alpha_m \neq 0 \quad (3)$$

where  $G = G(z)$  satisfies the second order linear ordinary differential equation:

$$G'' + \lambda G' + \mu G = 0, \quad (4)$$

$\alpha_i, \lambda$  and  $\mu$  are constants to be determined later, the positive integer  $m$  can be determined by considering the homogeneous balance between the highest order derivatives and nonlinear terms appearing in ODE (2).

**Step 3.** By substituting (3) into Eq. (2) and using second order LODE (4), collecting all terms with the same order of  $\left(\frac{G'}{G}\right)$  together, the left-hand side of Eq.(2) is converted into another polynomial in  $\left(\frac{G'}{G}\right)$ . Equating each coefficient of this polynomial to zero, yields a set of algebraic equations for  $\alpha_i, \lambda, V$  and  $\mu$ .

**Step 4.** Suppose that the constants  $\alpha_i, \lambda, V$  and  $\mu$  can be obtained by solving the algebraic equations in Step 3, since the general solutions of the second order LODE(4) have been well known for us, then substituting  $\alpha_i, \lambda, V$  and  $\mu$  and the general solutions of Eq.(4) into (3) we have more traveling wave solutions of the nonlinear evolution equation (1).

## Solution of the second order NLDEs

Consider a second-order non-linear differential equation of the form:

$$y'' + [2ay + f(x)]y' + af(x)y^2 = g(x) \quad (5)$$

Where  $y$  is a function of  $x$ . Normally it isn't possible to solve Eq.(5) by  $\left(\frac{G'}{G}\right)$  method and the above mentioned methods because  $f(x)$  and  $g(x)$  are involved here. For a better solution, let  $f(x)$  and  $g(x)$  are constant functions or  $g(x)$  is the  $k$  times of  $f(x)$ ,  $k$  being a real number.

Since the (5) is an ordinary differential equation (ODE) in  $x$ , we may start from **step2**.

Suppose that the solution of the ODE (5) can be expressed by a polynomial in  $\left(\frac{G'}{G}\right)$  as follows:

$$y(x) = \sum_{i=0}^m \alpha_i \left(\frac{G'}{G}\right)^i \quad (6)$$

Where  $\alpha_i$  are arbitrary constants provided  $\alpha_m \neq 0$ , while  $G = G(x)$  satisfies the second LODE of the form:

$$G'' + \lambda G' + \mu G = 0, \quad (7)$$

Where  $\lambda$  and  $\mu$  are constants.

Suppose the homogeneous balance between the highest order derivatives and the nonlinear terms in (5), we get  $m = 1$  and hence the solution takes the following form:

$$y(x) = \alpha_1 \left( \frac{G'}{G} \right) + \alpha_0 \quad (8)$$

where  $\alpha_1 \neq 0$ . On substituting Eq.(8) into the ODE(5) and using LODE(7), collecting all terms with the same powers of  $\left( \frac{G'}{G} \right)$  together and equating their coefficients to zero, yield a system of algebraic equations for the constants as follows:

$$\begin{aligned} -2a\alpha_1^2 + 2\alpha_1 &= 0 \\ 3\alpha_1\lambda - 2a\alpha_1^2\lambda + af(x)\alpha_1^2 - f(x)\alpha_1 - 2a\alpha_0\alpha_1 &= 0 \\ -2a\alpha_0\alpha_1\lambda + 2\alpha_1\mu - 2a\alpha_1^2\mu - f(x)\alpha_1\lambda + 2af(x)\alpha_0\alpha_1 + \alpha_1\lambda^2 &= 0 \\ -f(x)\alpha_1\mu - kf(x) - 2a\alpha_0\alpha_1\mu + af(x)\alpha_0^2 + \alpha_1\lambda\mu &= 0 \end{aligned}$$

Solving the above algebraic equations (using MAPLE-10 or MATHEMATICA), we have the following results:

$$\alpha_1 = \frac{1}{a}, \quad \alpha_0 = \frac{\lambda}{2a}, \quad \mu = \frac{\lambda^2}{4} - ak$$

Solving (7), we deduce after some reduction that

$$\frac{G'}{G} = \frac{1}{2} \sqrt{\lambda^2 - 4\mu} \left( \frac{C_1 \cosh \frac{1}{2} \sqrt{(\lambda^2 - 4\mu)} x + C_2 \sinh \frac{1}{2} \sqrt{(\lambda^2 - 4\mu)} x}{C_1 \sinh \frac{1}{2} \sqrt{(\lambda^2 - 4\mu)} x + C_2 \cosh \frac{1}{2} \sqrt{(\lambda^2 - 4\mu)} x} \right) - \frac{\lambda}{2} \quad (9)$$

Where  $C_1, C_2$  are arbitrary constants.

From (8) and (9), we deduce the traveling wave solutions of (5) as follows:

**Case 1:** If  $\lambda^2 - 4\mu > 0$ , then we have

$$y(x) = \frac{\sqrt{\lambda^2 - 4\mu}}{2a} \left( \frac{C_1 \cosh \frac{1}{2} \sqrt{(\lambda^2 - 4\mu)} x + C_2 \sinh \frac{1}{2} \sqrt{(\lambda^2 - 4\mu)} x}{C_1 \sinh \frac{1}{2} \sqrt{(\lambda^2 - 4\mu)} x + C_2 \cosh \frac{1}{2} \sqrt{(\lambda^2 - 4\mu)} x} \right) \quad (10)$$

**Case 2:** If  $\lambda^2 - 4\mu < 0$ , then we have

$$y(x) = \frac{\sqrt{\lambda^2 - 4\mu}}{2a} \left( \frac{-C_1 \sin \frac{1}{2} \sqrt{(\lambda^2 - 4\mu)} x + C_2 \cos \frac{1}{2} \sqrt{(\lambda^2 - 4\mu)} x}{C_1 \cos \frac{1}{2} \sqrt{(\lambda^2 - 4\mu)} x + C_2 \sin \frac{1}{2} \sqrt{(\lambda^2 - 4\mu)} x} \right) \quad (11)$$

**Case 3:** If  $\lambda^2 - 4\mu = 0$ , then we have

$$y(x) = \frac{1}{a} \left( \frac{C_2}{C_1 + C_2 x} \right) \quad (12)$$

In particular, if  $C_1 = 0, C_2 \neq 0, \lambda > 0, \mu = 0$ , then we deduce from (10) that

$$y(x) = \frac{\lambda}{2a} \left\{ \tanh \left( \frac{\lambda}{2} x \right) \right\} \quad (13)$$

Which represents the solitary wave solution of the equation.

## Conclusion

In this paper, we have seen that three types of traveling wave solutions in terms of hyperbolic, trigonometric and rational functions by using the  $(G'/G)$ -expansion method. This equation is very difficult to be solved by traditional methods and we conclude that the  $(G'/G)$ -expansion method is more powerful, effective and convenient. The performance of this method is reliable, simple and gives many new solutions. It is also a standard and computerizable method which allows us to solve complicated nonlinear evolution equations in the mathematical physics.

## References

1. Fan E.G. 2000, Extended tanh-function method and its applications to nonlinear equations, Phys. Lett. A 277, 212–218.
2. He J.H, Wu X.H., 2006 Exp-function method for nonlinear wave equations, Chaos Solutions Fract. 30, 700–708.
3. Liu S.K. and, Fu Z.T. 2001, Jacobi elliptic function expansion method and periodic wave solutions of nonlinear wave equations, Phys. Lett. A 289 , 69–74.
4. Second Order Nonlinear Ordinary Differential Equations, <http://eqword.ipmnet.ru> .
5. Wang M.L., Zhou Y.B. and Li Z.B., 1996, Application of a homogeneous balance method to exact solutions of nonlinear equations in mathematical physics, Phys. Lett. A, 216, 67–75.
6. Wang M.L., and Zhou Y.B., 2003, The periodic wave solutions for the Klein–Gordon–Schrödinger equations, Phys. Lett. A 318, 84–92.
7. Mingliang Wang, Jinliang Zhang, Xiangzheng Li, 2008, Application of the  $(G'/G)$ -expansion to traveling wave solutions of the Broer-Kaup and the approximate long water wave equations. Appl. Math. Comput, 206, 321-326.
8. Mingliang Wang, Xiangzheng Li, Jinliang Zhang, 2008, The  $(G'/G)$ -expansion method and traveling wave solutions of nonlinear evolution equations in mathematical physics. Physics Letters A, 372 , 417-423.

# An Invisible Watermarking Technique for Ownership Verification of Digital Images using Two Dimensional Discrete Cosine Transformation

K. M. Ibrahim Khalilullah<sup>1</sup>, Md. Habibullah Belali<sup>1</sup>, Md. Tanvir Hamid<sup>2</sup>

**Abstract:** This paper presents ownership verification algorithm for digital images, and a methodology for digital watermarking that may be generalized to audio, video, and multimedia data. A watermark is constructed from standard normal distributed pseudo random numbers, which is embedded as secret information into the significant spectral components of the Discrete Cosine Transformed (DCT) images. Embedded watermark will allow identifying the owner for verification of digital images. Experimental results show that the proposed algorithm has the desired properties such as invisibility, reliable detection and robustness against a wide range of imaging processing operations such as compression, noise, filtering etc. The goal of this implementation is to achieve identifying the owner, high performance, and reliability.

**Keywords:** Watermark, DCT, PSNR, MSE, Ownership verification, Cross-Correlation.

## Introduction

Digital image watermarking, which inserts an invisible signal directly into digital images, is a promising technology to defend the copyright of digital images. The availability of digital multimedia contents has been grown rapidly in the recent years. Today, digital media documents can be distributed via the World Wide Web to a large number of people without much effort and money. Unlike traditional analog copying, with which the quality of the duplicated content is degraded, digital tools can easily produce large amount of perfect copies of digital documents in a short period. This ease of digital multimedia distribution over the Internet, together with the possibility of unlimited duplication of this data, threatens the intellectual property (IP) rights more than ever. Therefore, there is a strong need for security services in order to keep ownership for the document owner and reliable to the customer. Watermarking plays an important role for that purposes.

The proposed applications of digital watermarking are <sup>1</sup>: broadcast monitoring, owner identification, proof of ownership, transaction tracking, content authentication, copy control, and device control. Some applications such as content authentication, ownership verification have been presented for copyright protection of electronic multimedia data by hiding secret information.

According to Working Domain, the watermarking techniques can be divided into two types: spatial and spectral-based approaches <sup>1</sup>. All methods are fighting to satisfy two basic requirements: watermark perceptual invisibility and watermark robustness against different group of attacks. The proposed algorithm supports the spectral-based approaches.

---

<sup>1</sup> Lecturer, Dept. of Computer Science & Engineering, Dhaka International University, Dhaka, Bangladesh.

<sup>2</sup> Dept. of Computer Science & Engineering, University of Dhaka, Dhaka, Bangladesh.

**Correspondence to:** K. M. Ibrahim Khalilullah, E-mail: ibrahim\_5403@yahoo.com

In this research work, we have implemented DCT-Based watermarking techniques. In DCT-Based watermarking, the host image is transformed into DCT coefficients, then largest 1000 coefficients are selected to embed watermark. In detection phase, vector projection is utilized to measure similarity between extracted watermark and original watermark.

### Literature Review

The earlier watermarking techniques were mostly spatial-domain approaches. The simplest approach was to alter the least significant bits (*LSBs*) of image pixels<sup>2</sup>; however, such a technique still has comparatively low-bit capacity and can't defy the loss data compression and image processing. The frequency-domain techniques can embed more bits of watermarks and resist more attacks than the spatial-based watermarking techniques. In DFT based approach Fourier coefficients have two components-phase and magnitude. Experiments explain that attack such as geometric rotation; don't modify the phase information of the coefficient. Therefore DFT based algorithm are robust to translation, rotation and scaling attacks<sup>3</sup>. Authors also reported that the phase based watermarking are relatively robust to change in image contrast. Modification of DFT magnitude coefficient is much perceptible than phase modification, one would expect that good image compressors would give much higher importance to preserving the DFT phase than the DFT magnitude, rendering the DFT magnitude based watermarking system vulnerable to image compression. All major compression schemes (JPEG, MPEG) preserved the DFT magnitude coefficients as well as preserved the DFT phase. In DCT based approach an algorithm that inserts watermark into the spectral components of image using techniques analogous to spread-spectrum communication. Watermarking in DCT is usually performed on the lower or mid frequencies

### Overview on Discrete Cosine Transformation

The discrete cosine transform (DCT) is closely related to the discrete Fourier transform. Like other transforms, the Discrete Cosine Transform (DCT) attempts to decorrelate the image data. After decorrelation each transform coefficient can be encoded independently without losing compression efficiency.

It is a separable linear transformation; that is, the two-dimensional transform is equivalent to a one-dimensional DCT performed along a single dimension followed by a one-dimensional DCT in the other dimension. The definition of the two-dimensional DCT for an input image  $A$  and output image  $B$  is,

$$B_{pq} = \alpha_p \alpha_q \sum_{m=0}^{M-1} \sum_{n=0}^{N-1} A_{mn} \cos \frac{\pi(2m+1)p}{2M} \cos \frac{\pi(2n+1)q}{2N}, \quad 0 \leq p \leq M-1, \quad 0 \leq q \leq N-1 \quad (1)$$

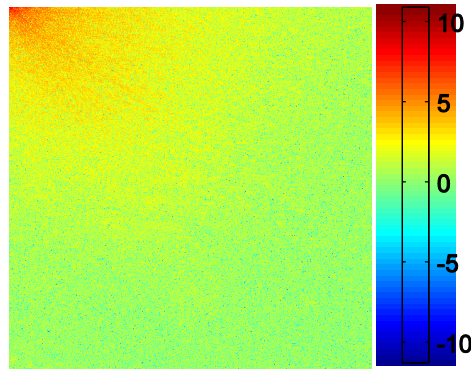
Where,

$$\alpha_p = \begin{cases} 1/\sqrt{M}, & p = 0 \\ \sqrt{2/M}, & 1 \leq p \leq M-1 \end{cases}$$

$$\alpha_q = \begin{cases} 1/\sqrt{N}, & q = 0 \\ \sqrt{2/N}, & 1 \leq q \leq N-1 \end{cases}$$

$M$  and  $N$  are the row and column size of  $A$ , respectively. If we apply the DCT to real data, the result is also real.

The next Fig.1 shows the discrete cosine transform for the Lena image. Notice that most of the energy is in the upper left corner.



**Fig.1: DCT transformation of Lena Image.**

The embedding algorithm focused on those spectral components that will change little when common image processing and noise corruption attacks are applied.

### Analytical description

We have implemented DCT-based image watermarking scheme by extracting largest  $N$  coefficients. The secret information has been embedded into the extracted coefficients by the following well-known equation<sup>3</sup>:

$$\hat{V}_i = V_i \cdot (1 + \alpha \cdot w_i), \quad (2)$$

Where  $i=1,2,\dots,N$ .  $\hat{V}_i$  is the watermarked coefficient (modified coefficient) and  $V_i$  is the original coefficient of the original image.  $w_i$  is the watermark and length of the watermark is  $N$ .  $\alpha$  is taken as 0.02.

The secret information is extracted from the watermarked image by using the following equation (Basically it's a reverse process of watermark embedding):

$$w_i = \left( \frac{\hat{V}_i}{V_i} - 1 \right) / \alpha, \quad (3)$$

Where  $i=1,2,\dots,N$  .  $w_i''$  is the extracted watermark from the watermarked coefficient. To calculate the similarity, we have utilized the vector projection as defined in the following equation <sup>4</sup>:

$$S = w \cdot w'' / \sqrt{w'' \cdot w''}, \quad (4)$$

The comparability of the extracted watermark with the original watermark is quantitatively analyzed by using Normalized Cross-Correlation ( $\psi$ ) <sup>5</sup>.

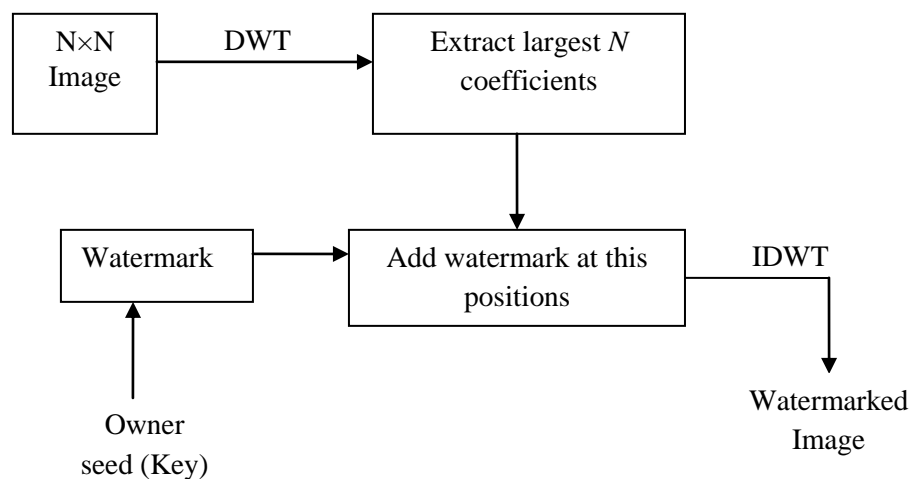
The Normalized Cross-Correlation ( $\psi$ ) is defined as:

$$\psi = \sum_i w_i'' \cdot w_i / \left( \left( \sqrt{\sum_i w_i \cdot w_i} \right) \cdot \left( \sqrt{\sum_i w_i'' \cdot w_i''} \right) \right) \quad (5)$$

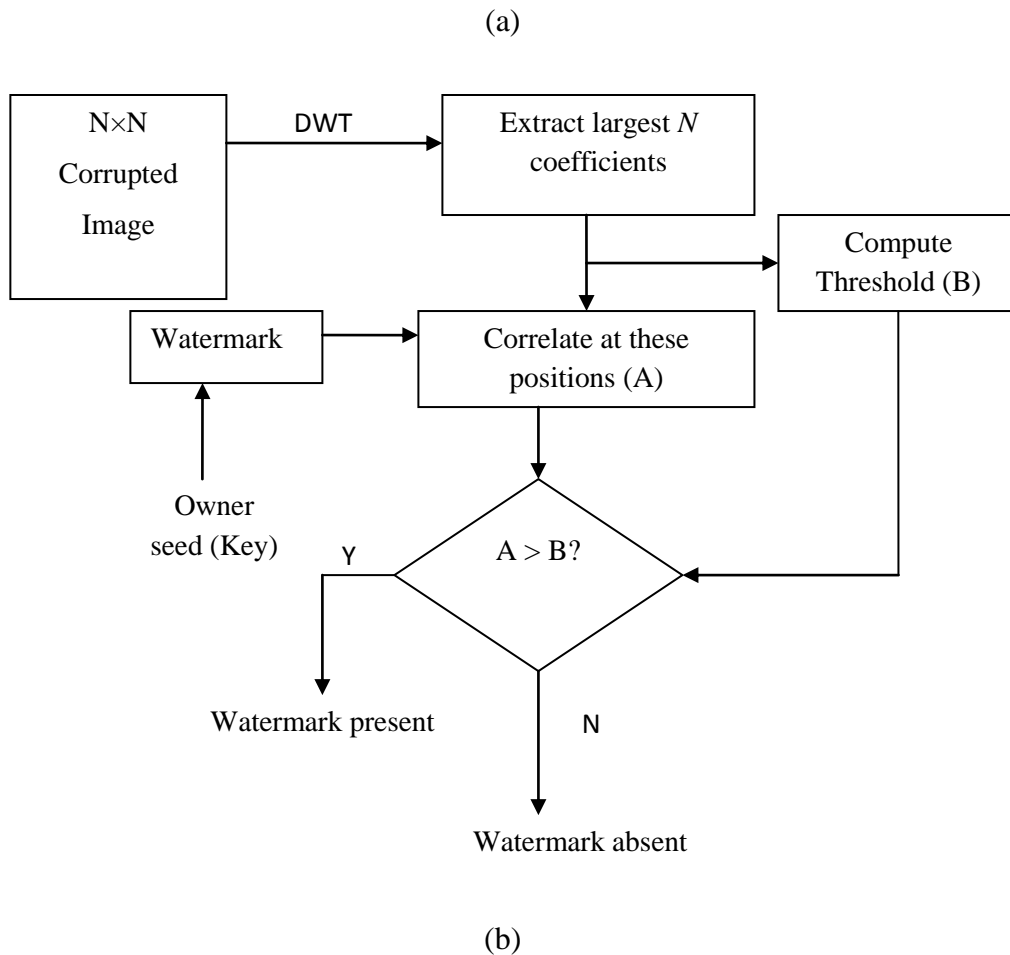
Image fidelity has also calculated to quantize the distortions on an image by using following equation <sup>5</sup>:

$$\varphi = 1 - \left( \frac{\sum_{m=1}^M \sum_{n=1}^N (f(m,n) - f'(m,n))^2}{\sum_{m=1}^M \sum_{n=1}^N f(m,n)^2} \right) \quad (6)$$

Where  $M$  and  $N$  are the size of the image.  $f(m,n)$  is the original image and  $f'(m,n)$  is the distorted image ,in this case watermarked or attacked images. The value of  $\psi$  and  $\varphi$  is between zero and one. Moreover, the bigger the value is, the better the watermark robustness is. This algorithm is explained in the following Fig.2.







**Fig.2: Block Diagram of this method; (a) Top part shows watermark embedding, (b) Bottom part shows watermark detection.**

### Experimental Results

Since most of researcher used Lena image in order to test the watermarking algorithm, in this experiment we have used the Lena image with size  $512 \times 512$ . To measure distortion of the image, we have used Peak Signal-to-Noise Ratio (PSNR). The PSNR is a metric, which can be used to measure distortion of an image. The perceptual quality of the watermarked image is quantitatively analyzed by using PSNR. This PSNR is defined as:

$$PSNR = 10 \log_{10} \frac{255^2}{MSE} (db) \quad (7)$$

$$\text{where, } MSE = \frac{1}{mn} \sum_{i=1}^m \sum_{j=1}^n (f(i, j) - f'(i, j))^2$$

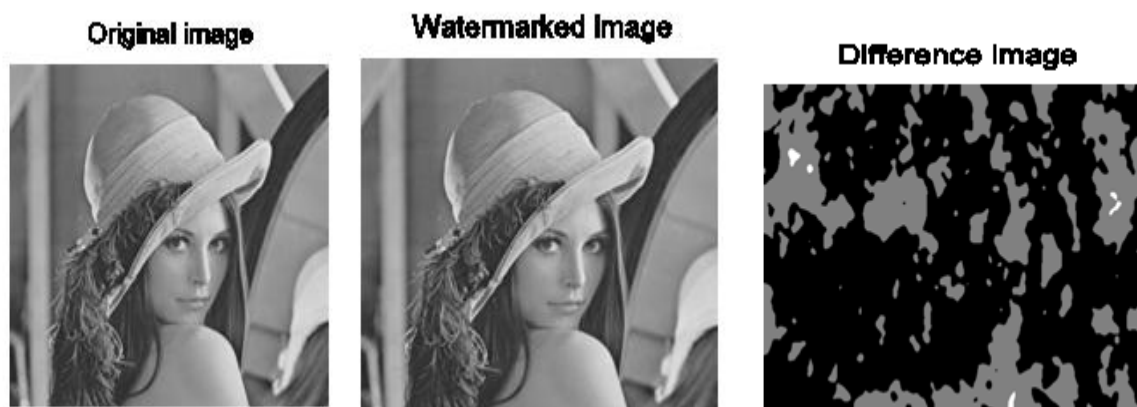
and  $f(i, j)$  is the original image,  $f'(i, j)$  is the distorted image. In watermarking techniques, there are two analysis parts. The first part is that the larger value of PSNR maintains better image quality. Therefore, the PSNR value should be larger during the perceptual quality measurement of watermarked image. In general, a watermarked image is acceptable by

human perception if its PSNR is greater than 30  $dB_s$  <sup>4-7</sup>. The second part is that the watermarking algorithm reflect better performance if it is capable to detect watermark from the watermarked image after attacking with lower PSNR value.

The Standard Normal Distributed pseudo-random number sequence  $\{W = w_1, w_2, \dots, w_N\}$ , where  $N$  is equal to the number of selected coefficients} is used as the watermark. This watermark is embedded into the largest 1000 selected DCT coefficients using Eq-1 to produce watermarked image. That is,

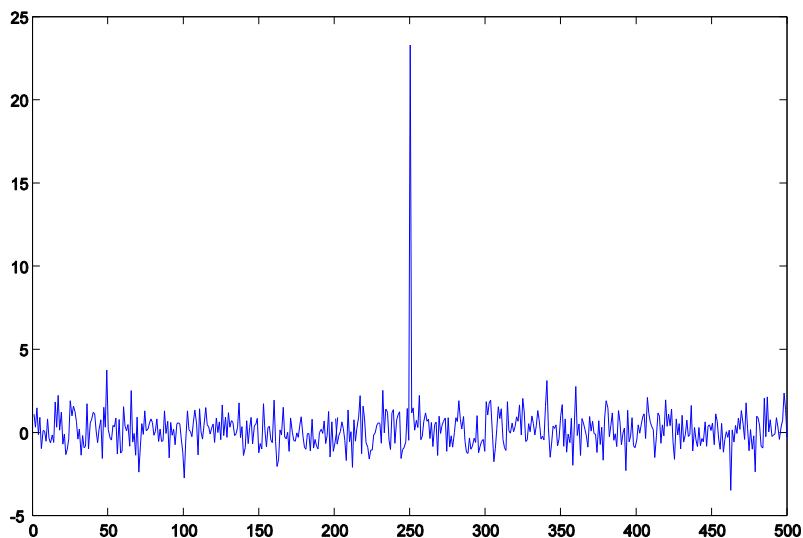
$$\begin{aligned} \text{Original Image} + \text{Watermark} &= \text{Watermarked Image} \\ \text{Watermarked Image} - \text{Original Image} &= \text{Difference Image} \end{aligned}$$

The original Lena image, the watermarked image, and their difference are shown in Fig.3:



**Fig.3: Original Lena image, Watermarked image (PSNR=52.7872), and their difference.**

The difference image basically represents the watermark in the spatial domain. The grey and white regions of the difference image represent watermark information. To detect the watermark, at first we have extracted the watermark from the watermarked image using Eq.-2. Then we have measured similarity between the extracted watermark and original or real watermark. Maximum similarity measurement value represents the existence of the watermark. The following Fig.4 depicts that several watermarks are randomly generated in the x-axis and corresponding similarity values (i.e. detector responses) between the extracted watermark and randomly generated watermark are shown in the y-axis. The similarity with real watermark is located at 250 in the x-axis, which is larger than the other fake watermark. So, it represents the existence of the watermark that ensures the ownership verification.



**Fig.4: Detector response for unattacked watermarked image with  $S = 23.2554$ ,  $\psi = 1.000$ ,  $\varphi = 1.000$ .**

Several common signal processing attacks such as Gaussian noise, salt & pepper noise, low pass filtering having window size  $3 \times 3$ , median filtering having window size  $5 \times 5$ , and JPEG compression are applied to the watermarked image to evaluate robustness of this algorithm. The following Fig.5 shows attacked watermarked image.

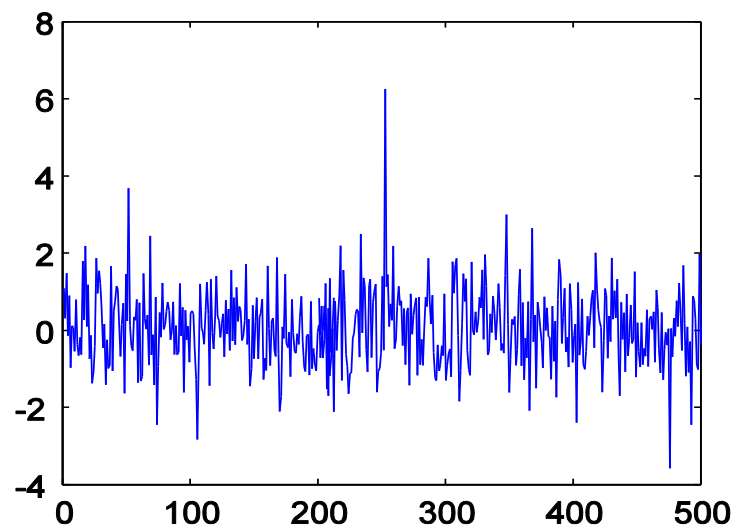


**Fig.5: (a) watermarked Lena image (without attack), (b) attacked by Gaussian noise (mean=0, variance=0.006), (c) attacked by Salt & Pepper noise (mean=0,**

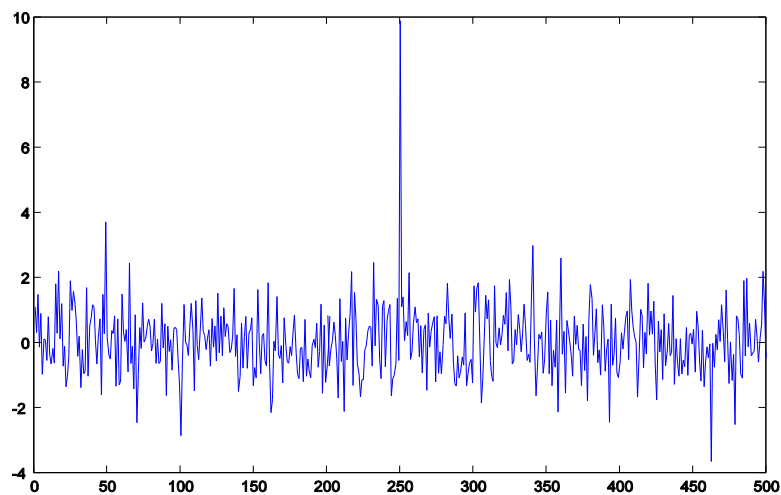
**variance=0.006), (d) attacked by Low pass filtering (Window size =3×3), (e) attacked by median filtering (Window size =5×5), (f) attacked by JPEG compression (Quality=20).**

Then, we have extracted watermark from attacked watermarked image. Then this extracted watermark is used to measure similarity (correlation) with real or fake watermarks. In following figures (from Fig.-6 to Fig.-10), we display the detector responses on the y-axis and randomly generated watermark on the x-axis. The correlation with the real watermark is located at 250 on the x-axis.

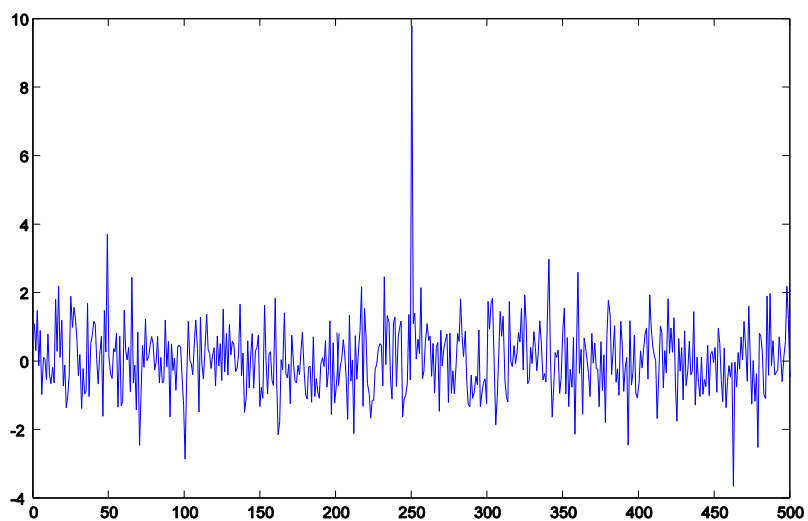
Similarly for the attacked watermarked image, the correlation value of extracted watermark and real watermark decreases somewhat, but the value is also larger than other. Therefore it represents the existence of our embedded watermark. The parameters (Similarity ( $S$ ), Normalized cross-correlation ( $\psi$ ), Image fidelity ( $\varphi$ )) in the figure caption represent robustness against attacks.



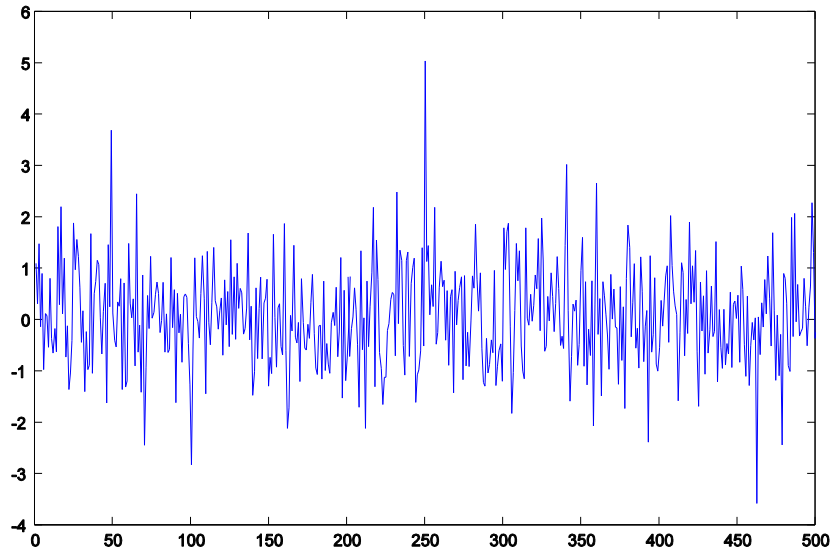
**Fig.6: Detector response for Gaussian noise attacked image with  $S = 6.2449$ ,  $\psi = 0.9945$ ,  $\varphi = 0.9890$ .**



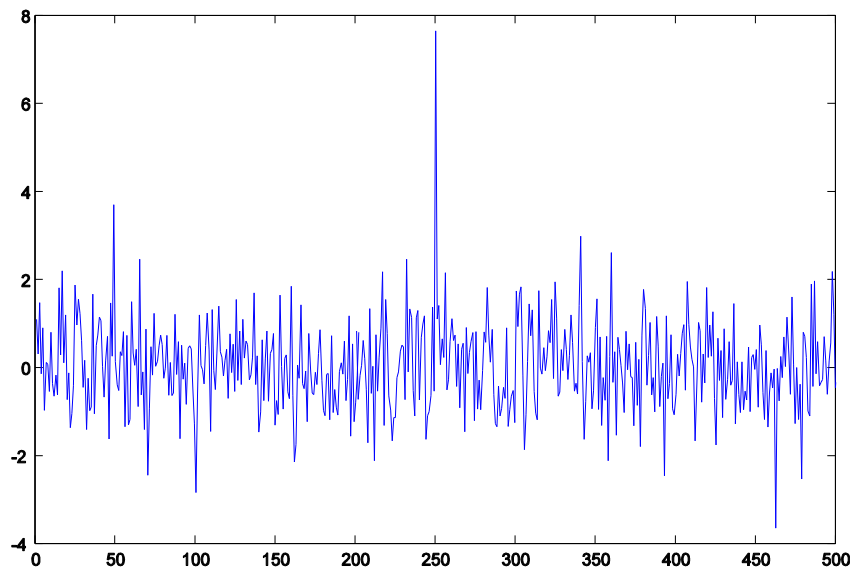
**Fig.7: Detector response for Salt & Pepper noise attacked image with  $S=9.9155$ ,  $\psi=0.9985$ ,  $\varphi=0.9971$ .**



**Fig.8: Detector response for Low pass filtering attacked image with  $S=9.8256$ ,  $\psi=0.9999$ ,  $\varphi=0.9997$ .**



**Fig.9: Detector response for median filtering attacked image with  $S = 5.0273$ ,  $\psi = 0.9989$ ,  $\varphi = 0.9977$ .**



**Fig.10: Detector response for JPEG compression attacked image with  $S = 7.6641$ ,  $\psi = 0.9992$ ,  $\varphi = 0.9984$ .**

The robustness of the method is given by the Peak Signal to Noise Ratio (PSNR) value of the retrieved image with respect to that of the original image. The value of PSNR for the proposed method is found out experimentally. The results of the calculations for the proposed spatial domain watermarking and a standard frequency domain watermarking using DCT are as given in Table I.

**Table-I: Comparison between Spatial domain method and frequency domain (DCT) method using PSNR value**

	<b>Spatial-domain method</b>	<b>Frequency-domain (DCT) method</b>
<b>Median filtering</b>	<b>25.85</b>	<b>31.8499</b>
<b>Low pass filtering</b>	<b>30.45</b>	<b>40.9783</b>
<b>JPEG compression</b>	<b>26.34</b>	<b>33.2647</b>
<b>Salt &amp; Pepper noise</b>	<b>24.57</b>	<b>30.6826</b>

### Conclusion

In this experiment, we have extracted largest DCT coefficients to embed the watermark. The algorithm is evaluated only for the common signal processing attacks. In this method, the extracted largest coefficients that change little when geometric attacks are applied. Since watermark detection typically consists of a method of correlation using original image which is extremely sensitive to the relative order of the coefficients in which the watermarks are placed within the image, such changes in the location of the watermarked coefficients decrease robustness. In future, we will use Empirical Mode Decomposition (EMD) in images to increase robustness against geometric attacks.

### References

1. Content Protection Status Report III, November 7, 2002, available at <http://judiciary.senate.gov/special/mpaal10702.pdf>.
2. Kaur et al., April 2013, Image Watermarking Using LSB, *International Journal of Advanced Research in Computer Science and Software Engineering*, Vol. 3, Issue 4, pp. 858-861.
3. I. J. Cox, F. T. Leighton, and T. Shamon, Dec. 1997, Secure spread spectrum watermarking for multimedia, *IEEE Transactions on Image Processing*, vol. 6, pp. 1673-1687.
4. John N. Ellinas, November 2007, A Robust Wavelet-Based Watermarking Algorithm Using Edge Detection, *Proceedings of World Academy of Science, Engineering and Technology*, volume 25, issn 1307-6884.
5. J Jiang, A Armstrong, 2002, Data hiding approach for efficient image indexing, *Electronics letters*, 7th, 38(23), pp. 1424-1425.
6. Inoue, H., A. Miyazaki, A. Yamamoto and T. Katsura, 1998, A digital watermark base on the wavelet transform and its robustness in image compression, in *Proc. IEEE Int. Conf. Image Processing*, vol. 2, pp. 391-395.
7. Ming-Shing Hsieh, 2001, Wavelet-based Image Watermarking and Compression, *Institute of Computer Science and Information Engineering National Central University, Chung-li, Taiwan 320 R.O.C, Phd Thesis*

# Effects of thermophoresis on unsteady MHD forced convective heat and mass transfer flow along a wedge

ATM. M. Rahman<sup>1,\*</sup> and M. K. Chowdhury<sup>2</sup>

**Abstract:** The present paper deals the effects of thermophoresis on an unsteady magnetohydrodynamic (MHD) forced convective heat and mass transfer flow along a wedge. The applied magnetic field strength as well as potential flow velocity have been considered as a function of the distance  $x$  and time  $t$ . The governing time dependent non-linear partial differential equations are transferred into locally similar ordinary differential equations and then solve numerically by applying Nachtsheim- Swigert shooting iteration technique along with sixth order Runge-Kutta integration scheme. Steady solutions are compared with previously published works which show excellent agreement. Numerical results for the dimensionless velocity, temperature and concentration profiles are displayed graphically as well as tabulated form for various values of physical parameters.

**Keywords:** Unsteady wedge flow, magnetohydrodynamic, thermophoresis

## Introduction

Thermophoresis, the motion of suspended particles in a fluid induced by a temperature gradient, is of practical importance in a variety of industrial and engineering applications such as design of thermal precipitators, study on the behavior of soot or seeding particles in combustion systems, nuclear reactor safety, gas cleaning, chemical or physical vapor deposition and micro contamination control, etc. Due to the practical importance of thermophoresis phenomenon many researchers (in detail Maxwell<sup>1</sup>, Talbot et al.<sup>2</sup>, Batchelor and Shen<sup>3</sup>, Sesse et al.<sup>4</sup>, Tsai and Liang<sup>5</sup>, Selim et al.<sup>6</sup>, Chamkha et al.<sup>7</sup>, Postelnicu<sup>8</sup>, Duwairi<sup>9</sup>) . Rahman et al.<sup>10-12</sup> obtained a local similarity solutions for unsteady two dimensional forced convective heat and mass transfer flow along a wedge with thermophoresis for various flow conditions. Very recently, Postelnicu<sup>13</sup> studied the thermophoresis particle deposition in natural convection over inclined surfaces in porous media.

The study of Magnetohydrodynamic flow of an electrically conducting fluid past an arbitrary shape surface has attracted the interest of many researchers in view of its important applications in many applications in many engineering problems. Recently the problem of magnetohydrodynamic flow over surface has become more important due to the possibility of applications in areas like nuclear fusion chemical engineering, medicine, and noiseless printing etc. Problem of MHD flow in the vicinity of plate has been studied intensively by a number of investigators (Gupta<sup>14</sup>, Pop et al.<sup>15</sup>, Takhar et al.<sup>16</sup>, Sharma

---

1. Associate Professor, Department of Computer Science and Engineering, Dhaka International University, Dhaka, Bangladesh.

2. Professor, Department of Mathematics, Bangladesh University of Engineering and Technology (BUET), Dhaka, Bangladesh.

\* Correspondence to: mrrahmandiu@yahoo.com

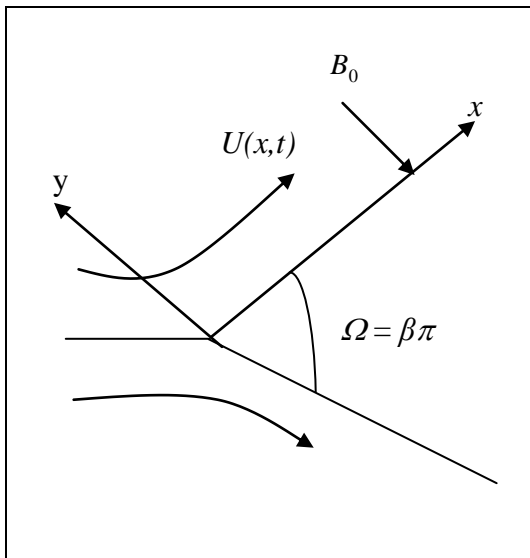


and Singh<sup>17</sup>). On the other hand Alam et al.<sup>18-20</sup> studied two-dimensional steady MHD convective heat and mass transfer flow over an inclined flat plate with various flow conditions in the presence of thermophoresis.

In this present research is to give a numerical investigation to the problem of unsteady MHD forced convective flow along a wedge. The external magnetic field is homogeneous and perpendicular to the wedge.

### Governing equations of the flow

Let us consider an unsteady two-dimensional MHD forced convective heat and mass transfer flow of a viscous incompressible electrically conducting fluid along a heated impermeable wedge (see Fig. 1) in the presence of thermophoresis. The angle of the wedge is given by  $\Omega = \beta\pi$ . The flow is assumed to be in the  $x$ -direction which is taken along direction of the wedge and the  $y$ -axis normal to it. The surface of the wedge is maintained at a uniform constant temperature  $T_w$  and a uniform constant concentration  $C_w$  which are higher than the ambient temperature  $T_\infty$  and ambient concentration  $C_\infty$  respectively. The effects of thermophoresis are being taken into account to help in the understanding of the mass deposition variation on the wedge surface. We further assume that due to the boundary layer behavior the temperature gradient in the  $y$ -direction is much larger than that in the  $x$ -direction and hence only the thermophoretic velocity component which is normal to the surface is of importance.



**Fig.1:** Physical model and co-ordinate system.

Then under the usual Boussinesq's and boundary layer approximations, the governing equations describing the conservation of mass, momentum, energy and concentration respectively can be written as follows (see also Rahman et al.<sup>10-12</sup>)

$$\frac{\partial u}{\partial x} + \frac{\partial v}{\partial y} = 0, \quad (1)$$

$$\frac{\partial u}{\partial t} + u \frac{\partial u}{\partial x} + v \frac{\partial u}{\partial y} = \frac{\partial U}{\partial t} + U \frac{\partial U}{\partial x} + \nu \frac{\partial^2 u}{\partial y^2} - \frac{\sigma B_0^2}{\rho} (u - U), \quad (2)$$

$$\frac{\partial T}{\partial t} + u \frac{\partial T}{\partial x} + v \frac{\partial T}{\partial y} = \frac{\lambda_g}{\rho c_p} \frac{\partial^2 T}{\partial y^2}, \quad (3)$$

$$\frac{\partial C}{\partial t} + u \frac{\partial C}{\partial x} + v \frac{\partial C}{\partial y} = D \frac{\partial^2 C}{\partial y^2} - \frac{\partial}{\partial y} (V_T C), \quad (4)$$

where  $u$ ,  $v$  are the velocity components in the  $x$  and  $y$  directions respectively,  $t$  is the time,  $\nu$  is the kinematic viscosity,  $B_0$  is the magnetic field strength,  $\rho$  is the density of the fluid,  $T$ ,  $T_w$  and  $T_\infty$  are the temperature of the fluid inside the thermal boundary layer, the wedge surface temperature and the fluid temperature in the free stream, respectively, while  $C$ ,  $C_w$  and  $C_\infty$  are the corresponding concentration,  $\lambda_g$  is the thermal conductivity of the fluid,  $c_p$  is the specific heat at constant pressure,  $D$  is the molecular diffusivity of the species concentration and  $V_T$  is the thermophoretic velocity which is defined as follows:

$$V_T = -\frac{k\nu}{T} \frac{\partial T}{\partial y}, \quad (5)$$

where  $k$  is the thermophoretic coefficient which ranges in value from 0.2 to 1.2 as indicated by Batchelor and Shen<sup>3</sup> and is defined from the theory of Talbot et al.<sup>2</sup> by:

$$\kappa = \frac{2C_s(\lambda_g / \lambda_p + C_t Kn)[1 + Kn(C_1 + C_2 e^{-C_3 / Kn})]}{(1 + 3C_m Kn)(1 + 2\lambda_g / \lambda_p + 2C_t Kn)}, \quad (6)$$

where  $C_1$ ,  $C_2$ ,  $C_3$ ,  $C_m$ ,  $C_s$ ,  $C_t$  are constants,  $\lambda_g$  and  $\lambda_p$  are the thermal conductivities of the fluid and diffused particles, respectively and  $Kn$  is the Knudsen number.

## Boundary conditions of the model

The applicable boundary conditions for the present model are

- (i) On the wedge surface ( $y = 0$ ):

$$u = 0, v = 0, T = T_w, C = C_w \quad (7a)$$

(no-slip and impermeable wall condition)

- (ii) Matching with quiescent free stream ( $y \rightarrow \infty$ ):

$$u = U(x, t), T = T_\infty, C = C_\infty, \quad (7b)$$

where  $U(x, t)$  is the potential flow velocity for the wedge flow which is taken as follows (see also Rahman et al.<sup>10-12</sup> and Sattar<sup>21</sup>):

$$U(x, t) = \frac{\nu x^m}{\delta^{m+1}}, \quad (8)$$

where  $m$  is an arbitrary constant and is related to the wedge angle and  $\delta$  is the time dependent length scale which is taken to be (see also Sattar<sup>22</sup>, Alam et al.<sup>23</sup>, and Mia et al.<sup>24</sup>) as

$$\delta = \delta(t). \quad (9)$$

## Dimensionless governing equation

To proceed we introduce the following non-dimensional variables:

$$\eta = y \sqrt{\frac{(m+1)}{2}} \sqrt{\frac{x^{m-1}}{\delta^{m+1}}}, \quad \psi = \sqrt{\frac{2}{m+1}} \frac{\nu x^{(m+1)/2}}{\delta^{(m+1)/2}} f(\eta), \quad \theta(\eta) = \frac{T - T_\infty}{T_w - T_\infty}, \quad \phi(\eta) = \frac{C - C_\infty}{C_w - C_\infty}, \quad (10)$$

where  $\eta$  is the similarity variable,  $\psi$  is the stream function that satisfies the continuity equation (1) and is defined by  $u = \partial\psi/\partial y$  and  $v = -\partial\psi/\partial x$ .

Now using equations (12)-(13) into equations (3), (4) and (9) we obtain the following non linear ordinary differential equations:

$$f''' + ff'' + \beta(1 - f'^2) - \frac{\delta^m}{\nu x^{m-1}} \frac{d\delta}{dt} (2 - 2f' - \eta f'') - \frac{2}{m+1} M(f' - 1) = 0, \quad (11)$$

$$\theta'' + \text{Pr} f\theta' + \frac{\delta^m}{\nu x^{m-1}} \frac{d\delta}{dt} \text{Pr} \eta \theta' = 0, \quad (12)$$

$$\phi'' + \text{Sc} f\phi' + \frac{\delta^m}{\nu x^{m-1}} \frac{d\delta}{dt} \text{Sc} \eta \phi' + \frac{\kappa \text{Sc}}{N_t + \theta} [(N_c + \phi)\theta'' + \theta'\phi' - (\frac{N_c + \phi}{N_t + \theta})\theta'^2] = 0, \quad (13)$$

where  $\beta = \frac{2m}{m+1}$  is the wedge angle parameter that corresponds to  $\Omega = \beta\pi$  for a total angle  $\Omega$  of the

wedge,  $\text{Pr} = \frac{\nu\rho c_p}{\lambda_g}$  is the Prandtl number,  $\text{Sc} = \frac{\nu}{D}$  is the Schmidt number,  $N_t = \frac{T_\infty}{T_w - T_\infty}$  is the

thermophoresis parameter,  $N_c = \frac{C_\infty}{C_w - C_\infty}$  is the concentration ratio,  $M = \frac{\sigma\beta_0^2 x}{\rho U}$  is the magnetic field

parameter.

The corresponding boundary conditions (7) becomes

$$f = 0, f' = 0, \theta = 1, \phi = 1 \quad \text{at} \quad \eta = 0, \quad (14a)$$

$$f' = 1, \theta = 0, \phi = 0 \quad \text{as} \quad \eta \rightarrow \infty. \quad (14b)$$

Now in order to make the equations (11)-(13) locally similar, let  $\frac{\delta^m}{\nu x^{m-1}} \frac{d\delta}{dt} = \lambda$ , (15)

where  $\lambda$  is taken to be a constant and thus can be treated as a dimensionless measure of the unsteadiness.

Hence equations (11)-(13) becomes

$$f''' + ff'' + \beta(1 - f'^2) - \lambda(2 - 2f' - \eta f'') - \frac{2}{m+1} M(f' - 1) = 0, \quad (16)$$

$$\theta'' + \text{Pr} f\theta' + \lambda \text{Pr} \eta \theta' = 0, \quad (17)$$

$$\phi'' + \text{Sc} f\phi' + \lambda \text{Sc} \eta \phi' + \frac{\kappa \text{Sc}}{N_t + \theta} [(N_c + \phi)\theta'' + \theta'\phi' - (\frac{N_c + \phi}{N_t + \theta})\theta'^2] = 0, \quad (18)$$

Further, we suppose that  $\lambda = \frac{c}{x^{m-1}}$ , where  $c$  is a constant so that

$$c = \frac{\delta^m}{\nu} \frac{d\delta}{dt}. \quad (19)$$

Thus integrating (19) we obtain that  $\delta = [c(m+1)\nu t]^{1/(m+1)}$ . (20)

Now taking  $c = 2$  and  $m = 1$  in equation (20) we obtain  $\delta = 2\sqrt{\nu t}$  which shows that the parameter  $\delta$  can be compared with the well established scaling parameter for the unsteady boundary-layer problems (see Schlichting<sup>25</sup>)

### Parameters of engineering interest

The parameters of engineering interest for the present problem are the local skin friction coefficient, local Nusselt number and the local Sherwood number which indicate physically wall shear stress, rate of heat

transfer and rate of mass transfer, respectively, and thermophoretic velocity. These physical quantities can be obtained from the following expressions:

$$\frac{1}{2} Cf \sqrt{2-\beta} = \text{Re}^{\frac{1}{2}} f''(0), \text{ where } \tau_w = \mu \left( \frac{\partial u}{\partial y} \right)_{y=0} . \quad (21)$$

$$Nu \sqrt{2-\beta} = -\text{Re}^{\frac{1}{2}} \theta'(0), \text{ where } q_w = -\lambda_g \left( \frac{\partial T}{\partial y} \right)_{y=0} . \quad (22)$$

$$Sh \sqrt{2-\beta} = -\text{Re}^{\frac{1}{2}} \phi'(0), \text{ where } M_w = -D \left( \frac{\partial C}{\partial y} \right)_{y=0} . \quad (23)$$

$$V_{Tw} = \left( \frac{V_T x}{\nu} \right)_{y=0} = -\sqrt{\frac{1}{2-\beta}} \text{Re}^{\frac{1}{2}} \frac{k}{1+N_t} \theta'(0) . \quad (24)$$

where  $\text{Re} = \frac{Ux}{\nu}$  is the Reynolds number.

Thus from equations (24) we observe that the non-dimensional thermophoretic velocity is proportional to the numerical values of  $-\theta'(0)$ .

### Numerical analysis

The numerical method used to solve the system of partial differential equations (16)-(18), subject to the boundary conditions (14) are solved using the Nachtsheim-Swigert<sup>26</sup> shooting iteration technique [for detailed discussion of the method see also Alam et al.<sup>27</sup>] with  $\beta$ ,  $\lambda$ ,  $Pr$ ,  $Sc$ ,  $\kappa$ ,  $M$ ,  $N_t$  and  $N_c$  as prescribed parameters. A step size of  $\Delta\eta = 0.01$  was selected to be satisfactory for a convergence criterion of  $10^{-6}$  in all cases. The value of  $\eta_\infty$  was found to each iteration loop by the statement  $\eta_\infty = \eta_\infty + \Delta\eta$ . The maximum value of  $\eta_\infty$  to each group of parameters  $\beta$ ,  $\lambda$ ,  $Pr$ ,  $Sc$ ,  $\kappa$ ,  $M$ ,  $N_t$  and  $N_c$  determined when the value of the unknown boundary conditions at  $\eta = 0$  does not change to successful loop with an error less than  $10^{-6}$ .

### Code validation

To check the validity of the present code, we have calculated the values of  $f(0)$ ,  $f'(0)$  and  $f''(0)$  for the Falkner-Skan boundary layer equation for the case  $\beta = 0$ ,  $\lambda = 0$  and  $M = 0$  for different values of  $\eta$ . Table-1 shows the comparison of the data produced by the present code and those of White<sup>28</sup>.

Table 1: Comparison of the present numerical results of Falkner-Skan boundary layer equation for the case of  $\beta = 0$ ,  $M = 0$  and  $\lambda = 0$ .

$\eta$	$f(\eta)$		$f'(\eta)$		$f''(\eta)$	
	Present work	White <sup>28</sup>	Present work	White <sup>28</sup>	Present work	White <sup>28</sup>
0.0	0.0000000	0.0000	0.0000000	0.00000	0.47027089	0.46960
0.5	0.05872926	0.05864	0.23456114	0.23423	0.46568757	0.46503
1.0	0.23332581	0.23299	0.46127690	0.46063	0.43494906	0.43438
1.5	0.51575598	.51503	0.66235843	0.66147	0.36218408	0.36180
2.0	0.88800281	0.88680	0.81770859	0.81669	0.25581418	0.25567
3.0	1.79780496	1.79557	0.97006212	0.96905	0.06763291	0.06771
4.0	2.78709815	2.78388	0.99872084	0.99777	0.00684790	0.00687
5.0	3.78738993	3.78323	1.00087632	0.99994	0.00025589	0.00026

## Results and discussion

From the numerical computations non-dimensional velocity, temperature and concentration profiles are found for different values of the various parameters occurring in the problem. In the calculations the values of the parameters namely wedge angle parameter  $\beta$ , unsteadiness parameter  $\lambda$ , magnetic parameter  $M$ , Prandtl number  $Pr$ , Schmidt number  $Sc$ , thermophoretic coefficient  $k$ , thermophoresis parameter  $N_t$  and concentration ratio parameter  $N_c$ .

In the simulation of the values of  $Pr$  are chosen as 0.71, 1.74, 2.97 which correspond physically to helium, water, methyl chloride, respectively. The values of Schmidt number  $Sc$  is taken for Carbon-Dioxide ( $Sc = 0.94$ ). The default values of the parameters are chosen as,  $\beta = 1.6$  (i. e.  $\Omega = 288^\circ$ ),  $\lambda = 0.5$ ,  $Pr = 0.71$ ,  $M = 0.5$ ,  $Sc = 0.94$ ,  $N_c = 3.00$ ,  $\kappa = 0.50$  and  $N_t = 2.00$ , unless otherwise stated.

### Effect of unsteadiness parameter

The effects of the unsteadiness parameter  $\lambda$  on the dimensionless velocity profiles within the boundary layer are shown in Figs. 2(a) when wedge angle parameter  $\beta$  takes the values 1.6 (i. e.  $\Omega = 288^\circ$ ). From these figures we observe that for large values of the parameter  $\lambda$  that is for higher unsteadiness, separation occurs even in the case of accelerated flow or of adverse pressure gradient ( $m > 0, \beta > 0$ ) which is on the contrary to the findings of Hartree<sup>29</sup> for the steady wedge flow. The reason is that in the steady case,  $m > 0$  is directly related to the accelerated flow but in the unsteady case some values of  $m > 0$  (not precisely

determined) are related to decelerated flow. Furthermore, from Fig. 2(a) for sufficiently strong unsteadiness. for  $\lambda > \lambda_{critical}$  (not precisely determined) it is observed that back flow occurs close to the wall indicating that unsteadiness may give rise to turbulence close to the wall. Velocity here is also found to decrease with the increase of the parameter  $\lambda$  within some domain  $\eta \leq \eta_{critical}$  and then for  $\eta > \eta_{critical}$  the tendency is reversed in the upper portion of the boundary layer. This is due to the fact that as  $\lambda$  intensifies the kinematic viscosity of the fluid decreases to its ambient value therefore back flow occurs very close to the surface of the body. But far away from the surface of the body  $\eta > \eta_{critical}$  this situation breaks down and fluid viscosity becomes stronger and reaches to its ambient value as a consequence velocity profile increases. This is an interesting phenomenon of unsteadiness. However, the behavior of the profiles remains the same as in the other cases. The effects of the unsteadiness parameter on the non-dimensional temperature and concentration profiles are displayed in 2(b)-2(c), respectively. From these figures we observe that both the temperature and concentration profiles decrease with the increasing values of the unsteadiness parameter  $\lambda$ .

### **Effect of wedge angle parameter**

The effect of changes in the wedge angle parameter  $\beta$  on the dimensionless velocity function  $f'$  against  $\eta$  is displayed in Fig. 3(a) for the values 0.0, 1/3, 1.0 and 1.8. The value of  $\beta = 0.0$  corresponds to wedge angle of zero degree i. e. flat plate,  $\beta = 1/3$  corresponds to the wedge angle of 60 degrees and  $\beta = 1.0$  corresponds to the wedge angle of 180 degrees i. e. stagnation point flow. From this figure it is clear that as the wedge angle parameter  $\beta$  increases the fluid velocity also increases. The results also show that the velocity profiles became steeper for larger values of the wedge angle parameter  $\beta$ . It is also mentionable here that separation is found to occur for very small non-negative values of  $\beta$ . Physically this means that unlike the case of steady solution obtained by Hartree<sup>29</sup>, the unsteady boundary layer is not able to support a small acceleration without separation. Nonetheless, the profiles for the unsteady case follow the same trend of those for the steady case (see Schlichting and Gersten<sup>30</sup>). This result is also consistent with the works of Sattar<sup>26</sup>. Fig. 3 (b) shows non-dimensional temperature profiles within the boundary layer for different values of the wedge angle parameter. From this figure we see that the temperature profiles decrease with the increasing values of the wedge angle parameter  $\beta$ . The effects of the wedge angle parameter on the dimensionless concentration profiles are shown in Fig. 3(c) and we observe that as the wedge angle parameter increases, the concentration profiles decrease.

### **Effect of magnetic field parameter**

Figs. 4 (a)-(c) shows typical velocity, temperature and concentration for various values of magnetic parameter  $M$ , respectively. Application of a magnetic field moving with the free stream has the tendency to induce a motive force which increases the motion of the fluid and decreases its boundary layer. This is accompanied by a decrease in the fluid temperature and concentration. In addition, the thermal boundary layer decreases as a result of increasing the strength of the magnetic field.

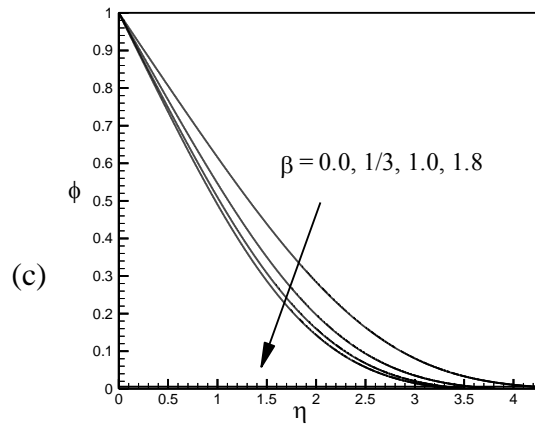
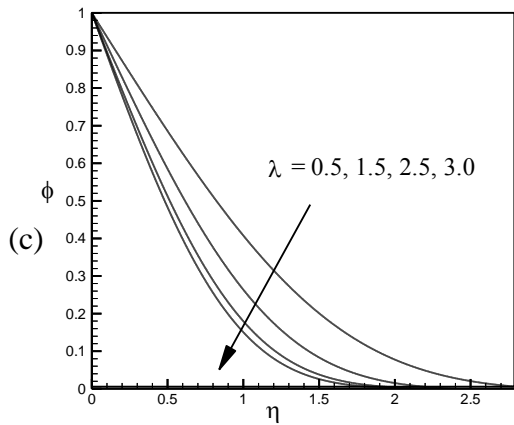
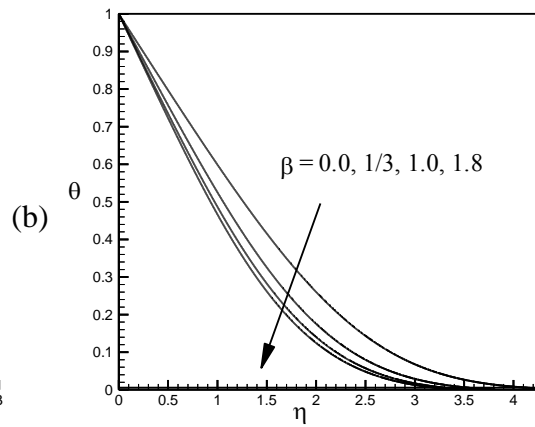
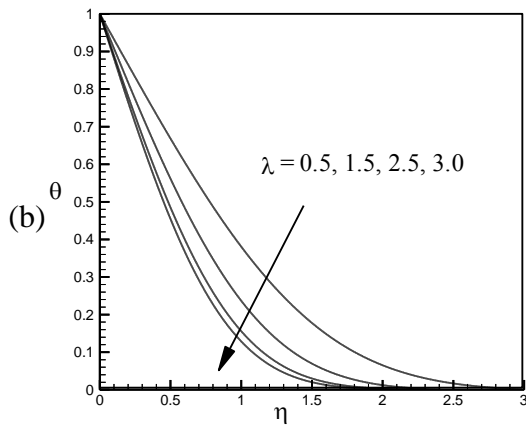
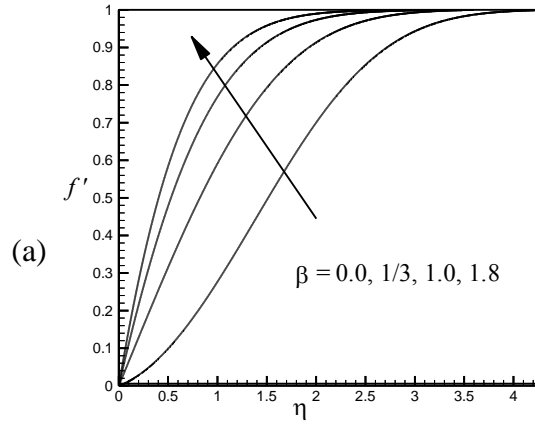
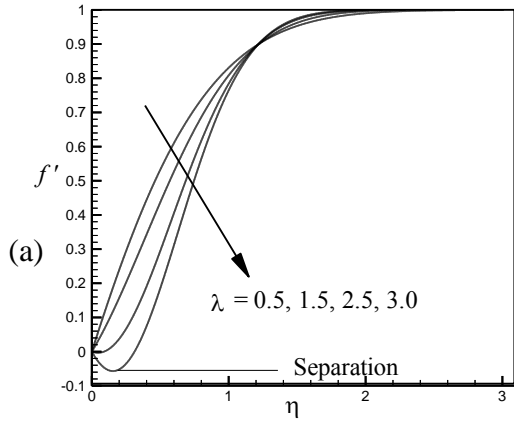
### **Effect of thermophoretic parameter**

The variation of dimensionless concentration profiles for various values of thermophoresis parameter  $N_t$ . From Fig. 5(a) it is readily seen the concentration within the boundary-layer decreases with the increasing values of the  $N_t$ . Physical significance of the values of the thermophoretic parameter used here: when the wall is warm, bearing in mind the definition of thermophoresis parameter,  $N_t T_w = (1 + N_t) T_\infty$ , so that  $N_t = 1$  means a wall twice warmer than the ambient fluid, i. e.  $T_w = 2T_\infty$ , while  $N_t = 1000$  describes a very cold wall.

### **Effect of thermophoretic coefficient and concentration ratio**

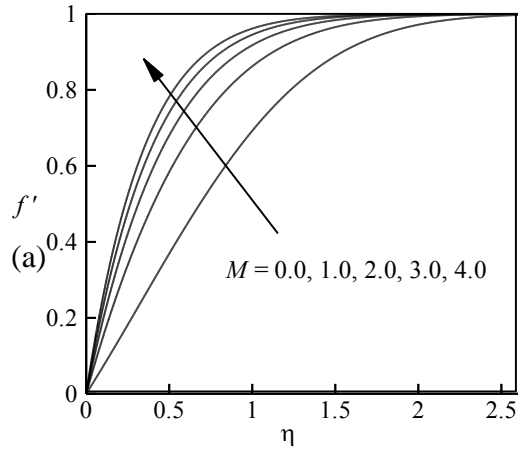
The variation of dimensionless concentration profiles for various values of thermophoretic coefficient  $\kappa$  and the concentration ratio  $N_c$  are shown in Figs.5 (b)-(c), respectively. From these figures, we observed that concentration profiles within the boundary-layer increases with the increasing values of the thermophoretic coefficient  $\kappa$  and the concentration ratio  $N_c$ .



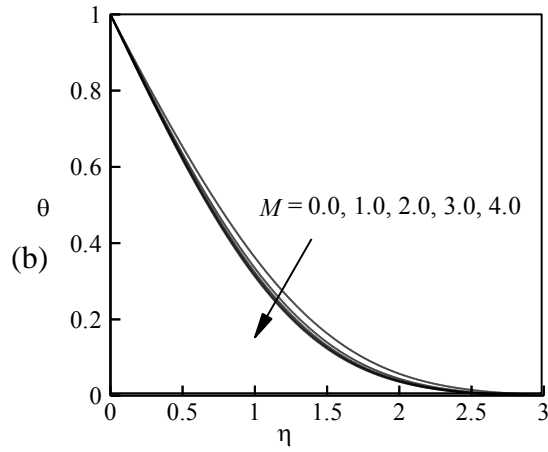
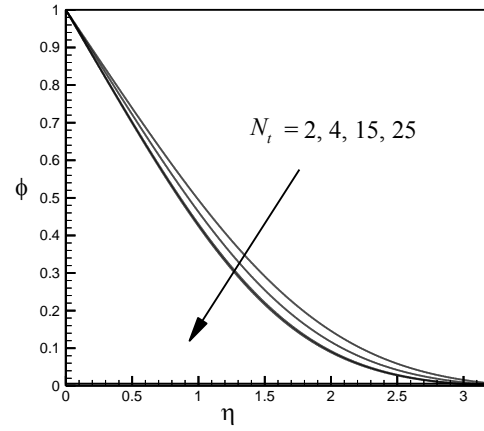


**Fig. 2:** Dimensionless (a) velocity, (b) temperature and (c) concentration for different values of  $\lambda$

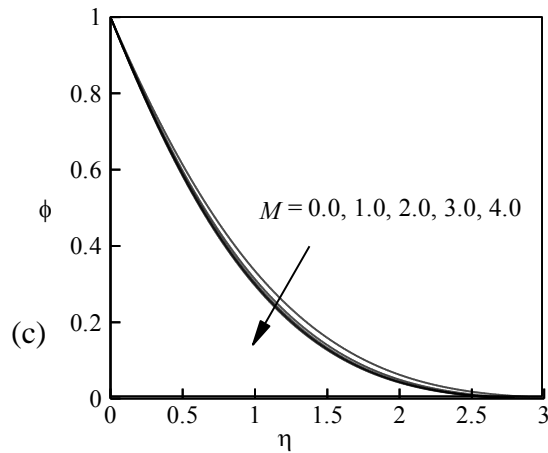
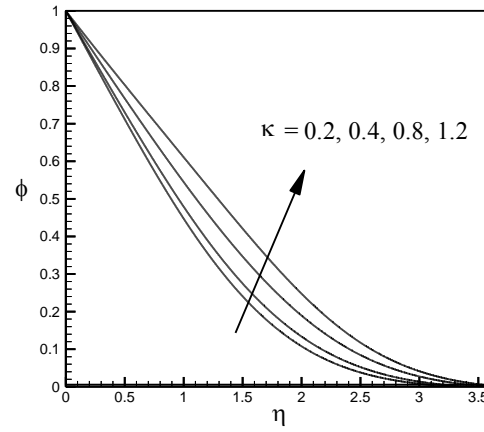
**Fig. 3:** Dimensionless (a) velocity, (b) temperature and (c) concentration for different values of  $\beta$



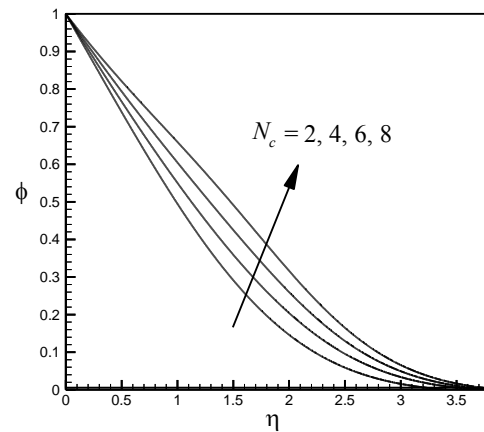
(a)



(b)

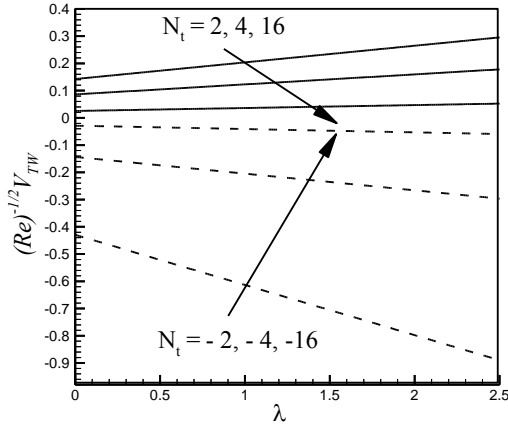


(c)

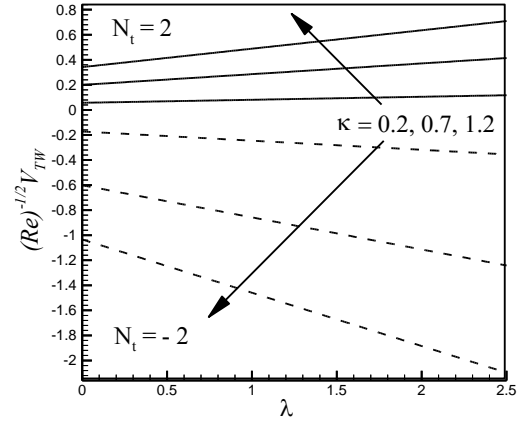


**Fig. 4:** Dimensionless (a) velocity, (b) temperature and (c) concentration for different values of  $M$

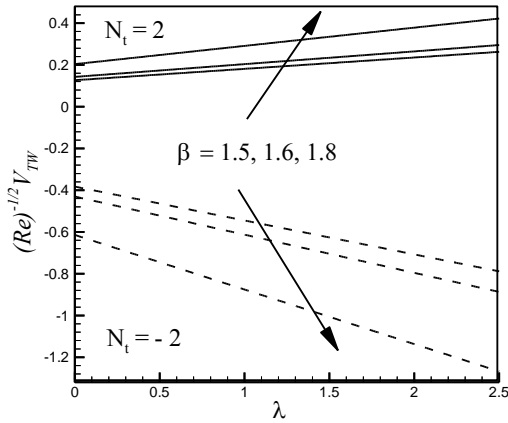
**Fig. 5:** Variation of dimensionless concentration profiles for various values of (a)  $N_t$  (b)  $\kappa$  and (c)  $N_c$ .



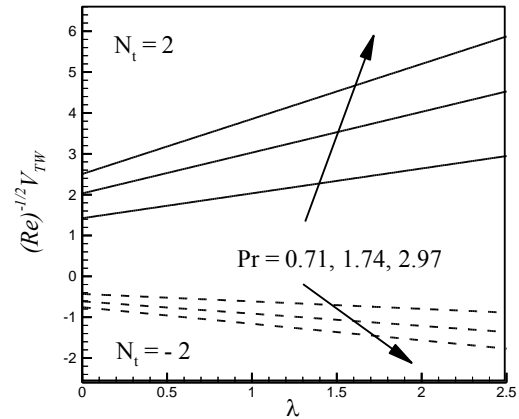
**Fig. 6:** Effects of  $\lambda$  and ( $N_t > 0$  and  $N_t < 0$ ) on thermophoretic velocity.



**Fig.7:** Effects of  $\lambda$  and  $\kappa$  on thermophoretic velocity.



**Fig. 8:** Effects of  $\lambda$  and  $\beta$  on thermophoretic velocity.



**Fig. 9:** Effects of  $\lambda$  and Pr on thermophoretic velocity.

### Effect of thermophoretic velocity

The combined effects of thermophoretic parameter  $N_t$  and unsteadiness parameter  $\lambda$  on the dimensionless wall thermophoretic velocity have been shown in Fig. 6. Increasing the thermophoretic parameter  $N_t$  leads to lower wall deposition velocities (curves  $N_t = -16, -4, -2$ ) and larger wall thermophoretic velocities (curves  $N_t = 2, 4, 16$ ) as seen in Fig. 6. This effect of  $N_t$  on  $V_{TW}$  is easily explained by inspection of equation (27).

The combined effects of  $\beta$  and  $\lambda$ ;  $\kappa$  and  $\lambda$ ;  $Pr$  and  $\lambda$ , on the dimensionless wall thermophoretic velocity ( $V_{tw} \text{Re}^{-\frac{1}{2}}$ ) when  $N_t = \pm 2$  are shown in Figs. 7-9, respectively. From these figures we see that thermophoretic velocity increases for increasing values of wedge angle parameter  $\beta$ , thermophoretic coefficient  $\kappa$  and Prandtl number  $Pr$  (when  $N_t > 0$ ) while it decreases (when  $N_t < 0$ ).

## Conclusion

In this paper we have discussed the effects of thermophoresis on an unsteady two-dimensional forced convective heat and mass transfer flow over a heated impermeable wedge. The applied magnetic field strength as well as potential flow velocity have been considered as a function of the distance  $x$  and time  $t$ . Using similarity transformations the governing equations of the problem have been transformed into non-linear ordinary differential equations and solved for local similar solutions by applying Nachtsheim-Swigert shooting iteration technique. The numerical results have been presented in the form of graphs and tables. From the present numerical investigations the following major conclusions may be drawn:

- (i) Velocity, temperature and concentration within the boundary layer decrease as the unsteadiness parameter increases.
- (ii) As the wedge angle parameter increases, the growth of the hydrodynamic, thermal and concentration boundary layers thickness decreases.
- (iii) Concentration within the boundary-layer decreases with the increasing values of the thermophoretic parameter whereas it increases as increases the thermophoretic coefficient as well as the concentration ratio.
- (iv) Wall thermophoretic velocity increases for increasing values of wedge angle parameter  $\beta$ , thermophoretic coefficient  $\kappa$  and Prandtl number  $Pr$  (when  $N_t > 0$ ) while it decreases (when  $N_t < 0$ ).

## References

- 1 Maxwell J.C, 1938 Kinetic theory of gases, Mc Graw-Hill, New Yourk.
- 2 Talbot L., Cheng R. K., Schefer A. W, Wills D. R., 1980, Thermophoresis of particles in a heated boundary layer, J. Fluid Mech., 101, 737-758.
- 3 Batchelor G. K., Shen C., 1985, Thermophoretic deposition of particles in gas flowing over cold surface, J. Colloid Interface Sci., 107, 21-37.

- 4 Sasse A. G. B. M., Nazarof W. W., Gadgil A. J., 1994, Particle filter based on thermophoretic deposition from natural convection, *Aerosol Sci. and Tech.*, 20, 227-238.
- 5 Tsai R., Liang L. J., 2001, Correlation for thermophoretic deposition of aerosol particles onto cold plates, *J. Aerosol Sci.*, 32, 473-487.
- 6 Selim A., Hossain M. A., Rees D. A. S., 2003, The effect of surface mass transfer on mixed convection flow past a heated vertical flat permeable plate with thermophoresis, *Int. J. Thermal Sci.*, 42, 973-982.
- 7 Chamkha A. J., Al-Mudhaf A. F., Pop I., 2006, Effects of heat generation or absorption on thermophoretic free convection boundary layer from a vertical flat plate embedded in a porous medium, *Int. Comm. Heat and Mass Transfer*, 33, 1096-1102.
- 8 Postelnicu A., 2007, Effects of thermophoresis particle deposition in free convection boundary layer from a horizontal flat plate embedded in a porous medium, *Int. J. Heat and Mass Transfer*, 50, 2981-2985.
- 9 Duwairi H. M., Damesh R. A., 2008, Effects of thermophoresis particle deposition on mixed convection from vertical surfaces embedded in saturated porous medium, *Int. J. Numer. Meth. Heat Fluid Flow*, 18(2), 202-216.
- 10 Rahman ATM. M., Alam M. S., Chowdhury M. K., 2012, Local similarity solutions for unsteady two dimensional forced convective heat and mass transfer flow along a wedge with thermophoresis *Int. J. Appl. Math and Mech.*, 8(8), 96-112.
- 11 Rahman ATM. M., Alam M. S., Chowdhury M. K., 2012, Effects of variable thermal conductivity and variable prandtl number on unsteady forced convective flow along a permeable wedge with suction/injection in the presence of thermophoresis. *Int. J. Energy & Technology* 4(4), 1-10.
- 12 Rahman, ATM. M., Alam M. S. and Chowdhury M. K., 2012, Thermophoresis particle deposition on unsteady two-dimensional forced convective heat and mass transfer flow along a wedge with variable viscosity and variable Prandtl number, *Int. Communications in Heat and Mass Transfer*, 39, 541-550.
- 13 Postelnicu A., 2012, Thermophersis partical deposition in natural convection over inclined surfaces in porus media, *Int. J. Heat and Mass Transfer*, 55, 2087-2094.

- 14 Gupta, A.S., 1962, Laminar free convection flow of an electrically conducting fluid from a vertical plate with uniform surface heat flux and variable wall temperature in the presence of magnetic field, *Zeitschrift fur Angewandte Mathematic and Physik*,13 (4), 324-333.
- 15 Pop, I., Kumari, M., Nath, G., 1994, Conjugate MHD Flow Past a Flat Plate, *Acta Mechanica*, 106 (3-4), 215-220.
- 16 Takhar, H. S., Chamkha, A. J., Nath, G., 1999, Unsteady Flow and Heat Transfer on a semi-Infinite flat plate with an aligned magnetic field, *International Journal of Engineering Science*, 37 (13), 1723-1736.
- 17 Sharma, P. R., Singh, G., 2009, Effects of Ohmic Heating and Viscous Dissipation on Steady MHD Flow Near a Stagnation Point on an Isothermal Stretching Sheet, *Thermal Science*,13 (1), 5-12.
- 18 Alam M. S., Rahman M. M., Sattar M. A., 2008a, Effects of variable suction and thermophoresis on steady MHD combined free-forced convective heat and mass transfer flow over a semi-infinite permeable inclined flat plate in the presence of thermal radiation, *Int. J. Thermal Sci.*, 47, 758-765.
- 19 Alam M. S., Rahman M. M., Sattar M. A., 2008b, Effects of chemical reaction and thermophoresis on MHD mixed convective heat and mass transfer flow along an inclined plate in the presence of heat generation/absorption with viscous dissipation and joule heating, *Can. J. Physics*, 86, 1057-1066.
- 20 Alam M. S., Rahman M. M., Sattar M. A., 2009, On the effectiveness of viscous dissipation and Joule heating on steady Magnetohydrodynamic heat and mass transfer flow over an inclined radiate isothermal permeable surface in the presence of thermophoresis, *Comm. in Nonlinear Sci. Numer. simulat.*, 14, 2132-2143.
- 21 Sattar M. A., 2011, A local similarity transformation for the unsteady two-dimensional hydrodynamic boundary layer equations of a flow past a wedge, *Int. J. Appl. Math. and Mech.*, 7(1), 15-28.
- 22 Sattar M. A., 1994, Unsteady hydromagnetic free convection flow with Hall current, mass transfer and variable suction through a porous medium near an infinite vertical porous plate with constant heat flux, *Int. J. Energy Res.*, 18(9), 771-775.

- 23 Alam M. S., Sattar M. A., 2010, Rahman M M and Postelnicu A. Local similarity solutions of an unsteady hydromagnetic convection flow of a micropolar fluid along a continuously moving permeable plate, *Int. J. Heat and Technology*, 28, 95-105.
- 24 Mia M. M., Sattar M. A. and Alam M. S., 2011, A local similarity solution for unsteady two-dimensional hydrodynamic boundary layer flow in a convergent channel, *Int. J. Energy and Technology*, 3, 1-4.
- 25 Schlichting H 1968, *Boundary layer theory*, McGraw Hill.
- 26 Nachtsheim P. R., Swigert P., 1965, Satisfaction of the asymptotic boundary conditions in numerical solution of the system of non-linear equations of boundary layer type, NASA TND-3004.
- 27 Alam M. S., Rahman M. M., Samad M. A., 2006, Numerical study of the combined free-forced convection and mass transfer flow past a vertical porous plate in a porous medium with heat generation and thermal diffusion, *Non-linear Analysis: Modelling and Control*, 11, 331-343.
- 28 White F. M., 2006, *Viscous Fluid Flows*, third ed. McGraw-Hill, New York.
- 29 Hartree D. R., 1937, On an equation occurring in Falkner and Skan's approximate treatment of the equations of the boundary layer, *Proc. Camb. Phil. Soc.*, 33, Par II.
- 30 Schlichting H., Gersten K., 2000, *Boundary Layer Theory*, 8<sup>th</sup> Edition, Springer- Verlag, Berlin/Heidelberg.

# Design and Implementation of Wireless Fire Alarm

Mohammad Tareq<sup>1</sup>, Md. Mazidul Islam<sup>1</sup>, Mahfuza Khatun<sup>1</sup>

**Abstract:** A wireless fire alarm and other passive circuit elements has been designed and implemented in this project. The designed alarm circuit could detect any kind of smoke and generate an alarm signal that would be sent to the control room by frequency modulation technique. The designed transmitter could operate around 100 MHz. A monopole antenna has been used for transmitting the signal carrying information in the free space. An antenna length of 41 cm has been used for design convenience. The transmitting signal has been successfully received at a distance of 53 feet without any disturbance by FM receiver. The operating transmitter was found to be 97 MHz and comparison shows a very good agreement between the measured value and the calculated value. The designed wireless fire alarm has been very dynamic in terms of performance and the transmitter part successfully demonstrates the basic principle of FM transmitter.

**Keywords:** *Wireless, Fire Alarm, FM*

## Introduction

### *The History of Fire Alarm Radio Transmitters*

Fire alarm technology has come a long way in the last 200 years. The first alarm systems were very primitive. They included people walking the street twirling fireman's rattles or someone ringing a church bell in order to alert volunteer firemen that there was a fire. In their own way, early Americans had developed their own form of wireless fire alarms. In 1852, the first public fire alarms were installed in Boston. Now all someone had to do to report a fire was to go to the nearest fire box and turn its crank. By doing so they set off a chain reaction. After being cranked, the fire box was equipped with technology that would send the message, via a telegraph-like system, to the dispatcher. The dispatcher would figure out what box the call came from and translate the box number into an address. Then the dispatcher would transmit the address to the nearest fire company who would, at long last, head for the scene of the fire. Even though fire alarm systems have come a long way since 1852, there are still some cities, all over the world, which still use public fire alarms. In fact, in many cities businesses have been mandated to connect to the public systems. This is done using a master box arrangement. While public fire reporting systems are quite reliable and continue to function under adverse weather conditions, they cannot be used to transmit any information except the presence of a fire. Plus, most cities do not already have a system like this, and in today's financial market it would not be cost-effective to install one. Modern wireless technology has brought new, multifunctional fire reporting methods, such as fire alarm radio transmitters, to the forefront. Some of these new technologies include cellular transmitters, digital alarm communicator systems, private microwave radio systems, radio frequency transmission, and coded radio boxes. These systems don't require an elaborate system of wires like the old public ones did. They can be used by anyone wherever they are. One of the new technologies uses local radio transmission using coded radio boxes. This type of a system can be powered by a utility distribution system, power supplied by the user, or batteries. Big cities which have no buildings with copper infrastructure support the coded-box system well. The fire alarm radio transmitter system may also prove beneficial in cities where conductor maintenance has become cost-prohibitive.

---

**1.Lecturer, Dept. of EETE, e-mail: tareq.mhd@gmail.com**



There are both one-way and two-way radio alarms on the market. A one-way system only sends alarms, while a two-way is able to both send and receive. Fire alarm technology has come a long way from the wireless fireman's rattle to the fire alarm radio transmitters.

Radio based wire-free fire alarms<sup>[9]</sup> offer a solution on premises where it is not practicable to disrupt a building whilst engineers cable in a conventional system. Wire free systems offer unique benefits in that the sensors can be quickly put in place with very little damage caused to the building fabric. There are no expensive Fire resistant cables to onsite and the system can easily be upgraded if the building is re-configured and even moved to another site. Full analogue addressable systems are available and range from 4 to 96 zones in size. These systems are fully net-workable with radio LAN, and have a wide range of devices available. The radio frequencies used are license free and the equipment is fully approved. The technology is well tried and the UHF radio frequencies used have never been known to have had an interference triggered false alarm.

### ***Fire alarm system with different types of sensors and smoke detectors***

A fire alarm system utilizes outputs from different types of fire sensors, such as photoelectric smoke sensors or ionization type smoke sensors and combines those outputs by subtraction so as to establish a delay interval during which one or both of the sensor output values must exceed a predetermined threshold value to cause the system to go into an alarm condition. Prior to subtracting the outputs from one another, each of the outputs can be raised to a predetermined exponential value so as to emphasize the effects of larger sensor output values. Where the two types of fire sensors each are generating outputs indicative of a fire condition, the calculated delays will be relatively short. In instances where only one of the two sensors is generating an output indicative of a fire condition, the calculated delay will be longer, so as to inhibit false alarms.

Smoke alarms are the most common types of fire alarms. Often, the term smoke alarm is used interchangeably with fire alarm. Smoke alarms<sup>[10]</sup> actually detect smoke and not the actual fire. There are generally two types of smoke alarms.

**Photoelectric** – This type of fire alarm sees the smoke. This fire alarm is particularly responsive to smoldering fires or the type of fires that give out a lot of smoke. These are ideal for places where there are things like PVC or foam. This fire alarm, though, is slightly more expensive than ionization alarms. This fire alarm must also be kept clean since it can give off false alerts due to dust and insects.

**Ionization** – This type of fire alarm detects the invisible particles caused by combustion. As opposed to the photoelectric fire alarm this type feels the smoke. This can best detect flaming fires with no visible smoke. However, you should not place this type of fire alarm in the kitchen as it is susceptible to false alarms. It is also cheaper than other types of fire alarms. However, this type of fire alarm does contain a bit of radioactive material, so it is best to be careful.

### ***Basic Principle of Operation of Wireless Fire Alarm***

The operation of a wireless fire alarm is very simple and generally follows the sequence shown on the fig. 1. When there is a fire or smoke in the room the detector which is very

sensitive quickly detects it and generates a signal or alarm which is transmitted by FM radio transmission<sup>[1]</sup> and received at the control room.



**Fig. 1:** Block Diagram of a Wireless Fire Alarm

A frequency generator is used to generate a frequency radio signal with a particular band range, and for mixing the frequency radio signal with the transmission data, to make a transmission signal having a particular frequency; and a transmitter for amplifying the transmission signal having the particular frequency up to a predetermined level and for transmitting the same through an antenna.

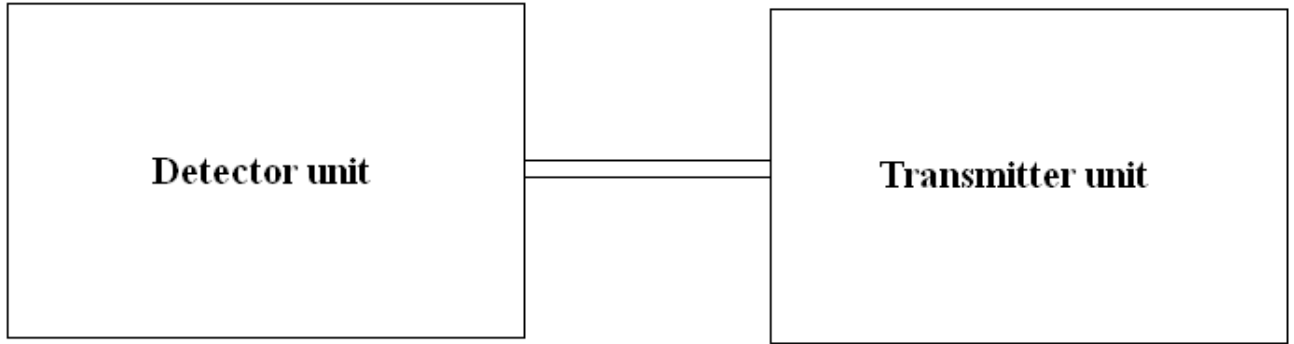
The receiver receives the transmission signal via a second antenna and filters the transmission signal to acquire desire data including the identification code and location data and compares the identification code with registered codes.

### ***Objective of this work***

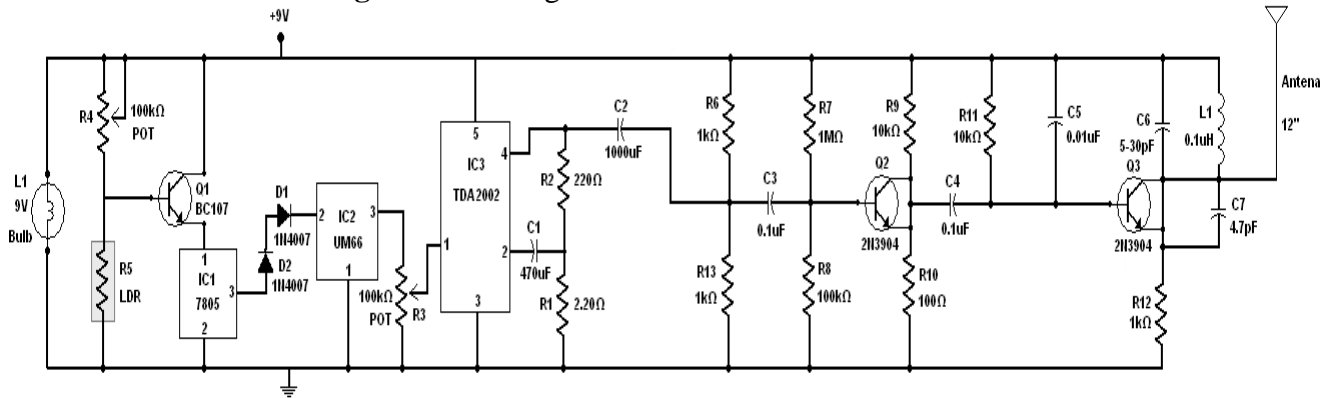
This project has been designed to build a device that would detect any presence of fire and immediately send signal to the control room to take necessary actions. The project also involved developing a mechanism that would allow the sensitivity and hence the power of the transmitted signal to be controlled. As a part of this project a FM transmitter has been designed that would transmit signal at a particular frequency and could be received easily with a FM receiver. Most importantly design and build a cost effective wireless fire alarm that would work under any condition and be easily set up in commercial and residential areas.

### **Our Circuits and Data**

The complete circuit consists of two major units, a detector and a transmitter. The detector unit's work was to sense any smoke and trigger an alarm. The transmitter unit transmits this signal by frequency modulation<sup>[1]</sup> and is received at the control room via a simple FM receiver. The whole circuit contains many electrical and electronic components such as resistor, capacitor, inductor, and IC's like IC7805, TDA2002, UM66 and transistor 2N3904.



**Fig. 2:** Block diagram of wireless fire alarm



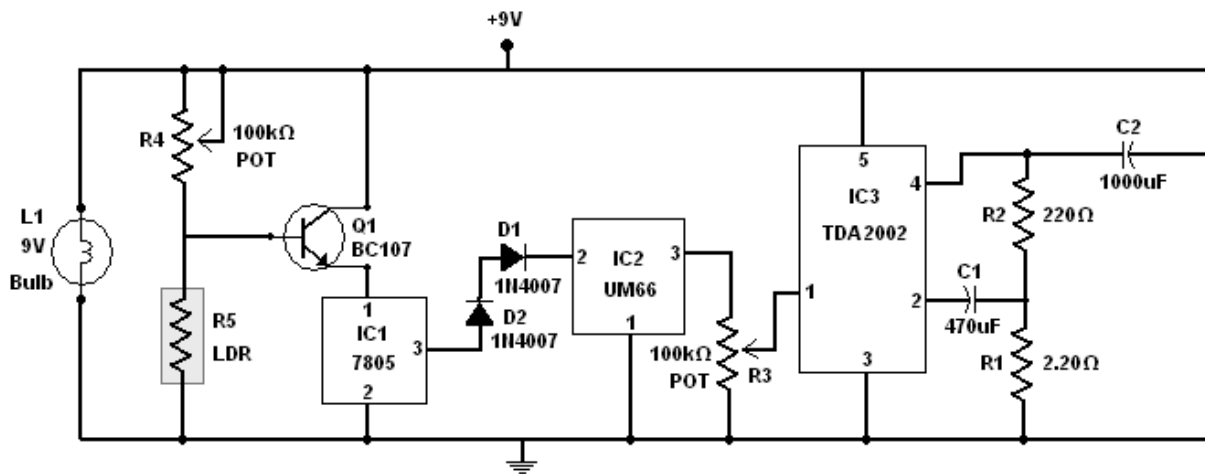
**Fig. 3:** Complete circuit diagram of wireless fire alarm circuit

The block diagram of the circuit is shown in the figure 2 where the complete circuit diagram of wireless fire alarm circuit is given in the figure 3. The purpose of the circuit is to detect smoke and generate an alarm and transmit it over the air using FM transition.

The circuit can be broken into two simple portions. First, there is the smoke detector and alarm generator. The detector unit is shown through block diagram in the figure 4 and with the circuit diagram in the figure 5.



**Fig. 4:** Block diagram of detector unit



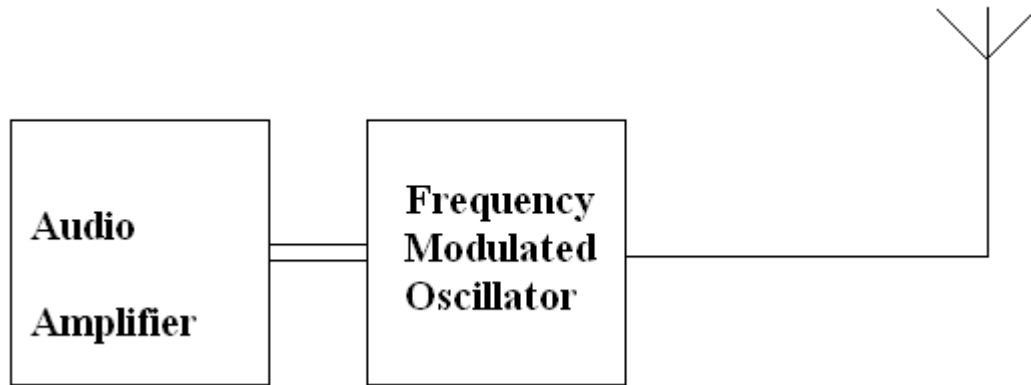
**Fig. 5:** Detector unit

Detector unit is a simple fire alarm circuit based on a LDR and lamp pair for sensing the fire. The alarm works by sensing the smoke produced during fire. The circuit produces an audible alarm when the fire breaks out with smoke. When there is no smoke the light from the bulb will be directly falling on the LDR. The LDR resistance will be low and so the voltage across it (below 0.6V). The transistor<sup>[5]</sup> will be OFF and nothing happens. When there is sufficient smoke to mask the light from falling on LDR, the LDR resistance increases and so do the voltage across it. Now the transistor will switch to ON. This gives power to the IC1 and it outputs 5V. This powers the tone generator IC UM66 (IC2) to play music. This music will be amplified by IC3 (TDA 2002). The diode D1 and D2 in combination drops 1.4 V to give the rated voltage (3.5V) to UM66. UM 66 cannot withstand more than 4V. Potentiometer (POT) R4 can be used to adjust the sensitivity of the alarm, which means turning it up towards more resistance makes the circuit less sensitive to light, while turning it down towards less resistance makes the circuit more sensitive to light. By adjusting the POT, it is possible to turn the alarm on and off just by passing shadow over it. POT R3 can be used for varying the volume of the alarm. That is it can be used to control the amplifier TDA2002's gain. This sound will be transmitted by the FM transmitter. So before being transmitted, this audio signal should be amplified to optimum level.

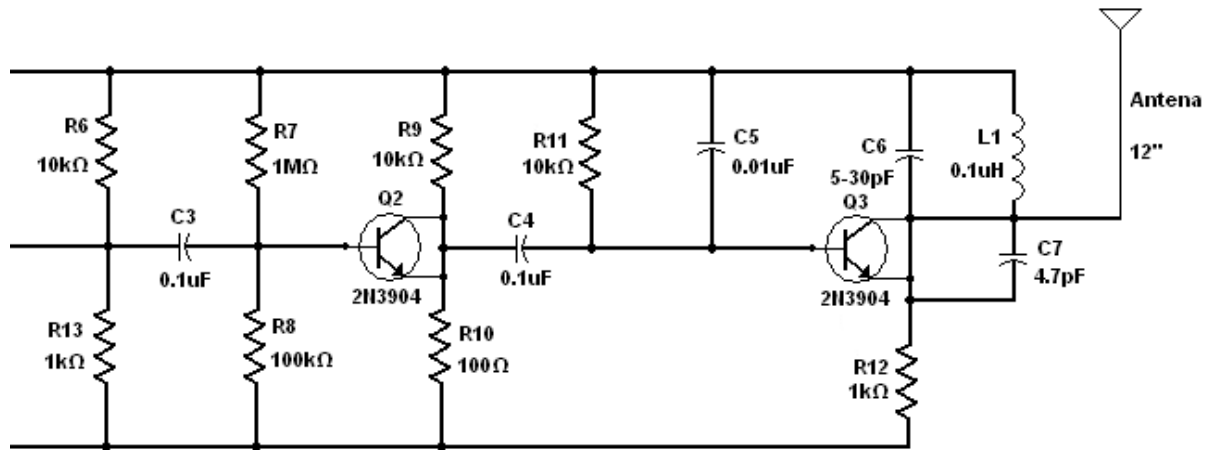
Next is the FM transmitter part which is shown by using block diagram in the figure 6 and the circuit diagram is given in the figure 7.

The FM transmitter's input is the audio signal generated by the alarm circuit. The first transistor Q2 works as an audio amplifier, which amplifies the audio signal even more. The second transistor works as an oscillator<sup>[4,5]</sup> circuit. The inductor L1 and capacitor C6 work together as an oscillator and generate a frequency in the FM band. Therefore it transmits the signal at a particular frequency, which, if tuned properly, will be received at the receiver. Capacitor C3 is a DC blocking capacitor and C4 is a coupling capacitor. Antenna tuning is done by adjusting inductance L1 and capacitance C6 combined with the active antenna<sup>[3]</sup> (but

distinct and separate from the active antenna). The inductance and capacitance provides the reactance which combines with the inherent reactance of the active antenna to establish a resonance in a circuit including the active antenna.



**Fig. 6:** Block diagram of FM transmitter



**Fig. 7:** Circuit diagram of FM transmitter

The established resonance is at a frequency other than the natural electrical resonant frequency of the active antenna. Adjustment of the inductance or capacitance changes this resonance. The signal is transmitted at this resonant frequency.

### Calculations

Let, frequency = 95MHz and capacitance = 30pF

We know, resonant frequency for oscillator<sup>[2]</sup>, 
$$F_r = \frac{1}{2\pi(\sqrt{LC})}$$

From here, using the above values for frequency and capacitance, inductance, L was found to be 94nH.

Assuming length,  $l = 1\text{cm}$

Total number of turns, 
$$n = \sqrt{\frac{L(90 \times r) + (10 \times l)}{r^2}}$$

From here, n was found to be 13 turns

Assuming free space propagation<sup>[6]</sup>,  $c = f \times \lambda$

Therefore, 
$$\lambda = \frac{3 \times 10^{10} \text{ cm.s}^{-1}}{95 \text{ MHz}} = 316 \text{ cm}$$

$$\text{Antenna Length} = \frac{\lambda}{8} = 41 \text{ cm}$$
 has been used for design convenience.

The transmitting frequency was found to be 97MHz in practically where the range of the transmitter circuit was found to be more than 53 feet on the same floor.

## Discussions and Conclusions

### *Discussions*

The basic elements of a wireless fire alarm that were considered are sensor, voltage limiter, musical IC, audio amplifier, oscillator generating carrier signal, FM modulator, RF amplifier, power amplifier and antenna for the transmission of the modulated signal. In addition to these basic elements some additional circuit elements are used as well to achieve better performance.

### *Power Supply*

The circuit needed a 9 Volt DC power supply. Initially we used an AC- to-DC adapter for power supply which converted 220 Volts AC to 9 Volt DC voltages. Since obtaining the desired voltage by varying the knob of the adapter was difficult and the voltage obtained was not stable, we shifted to a 9 Volt DC battery. This battery has been more stable in supplying a constant voltage than the adapter.

### *Detector Unit*

The circuit we have designed contained a LED and sensor at the beginning. Since this unit did the functioning of detection of smoke or fire it was carefully designed so that it has maximum sensitivity. A resistor in series was introduced with the LED so that it does not get heated up. Also the resistors in transmitter circuit were varied and changed so as to get the clearest sound at the receiver.

### ***Audio Amplifier***

The alarm signal from the musical IC was directly fed into the audio amplifier TDA 2002 IC, which was used to amplify the audio signal. A second stage amplification was done at the transmitter unit before being frequency modulated.

### ***Oscillator Design***

The oscillator<sup>[4,8]</sup> in the FM transmitter is for generating a high frequency carrier signal, which is then modulated in accordance to the audio signal. To design the oscillator the oscillation frequency and the value of inductance of the coil of the tank has to be determined. The oscillator used was a Colpitts type oscillator, except the 4.7pF capacitor connected to the circuit. The value of inductance was determined analytically using the designers rule for coil designing, and had a small deviation with the actual value measured by an L-C meter. The frequency was calculated using the Colpitts oscillation frequency expression neglecting the 4.7pF capacitor. The frequency was found to be 97 MHz .The actual value at which the circuit operated was found almost same as the calculated value.

### ***Antenna Designing***

In our design a monopole antenna<sup>[7]</sup> was used, though any sort of antenna such as dipole antenna could have been used in the design for signal transmission in the free space. Folded dipole antenna has high radiation impedance and its radiation pattern was found to be better than monopole antenna, though in practical cases monopole antenna is used for FM transmission. We have chosen antenna length to be  $\lambda/8$ , which is almost 41cm.

### ***Range of the circuit***

The range of the transmitter circuit was determined by placing the receiver at different distances up to which the audio signal is clearly heard. The range was found to be more than 50 feet on the same floor. The signal could not be received clearly at different floor from the transmitter as harmonics effect there was too strong. The received power reduces with the increment in distance as expected. The range was found to be more at night and the sound quality of the signal was better too. This was due to less amount of electrical equipment working at night reducing the overall interference.

### ***Suggestions for Future Work***

Design improvements that could be considered in future are listed below:

1. More sensors, such as temperature sensor, humidity sensor and pressure sensor can be added for better prediction and detection of fires.

2. The musical IC could be replaced by a custom made IC which will generate signal giving out the address of the particular fire affected room.
3. The transmitted signal can data signal transmitting time, location and origin of the fire.
4. Coding the signal before transmission will enhance the security, reduce multi-path fading, and allow many transmitters to use the same channel.
5. A speaker could be attached to the TDA2002 audio amplifier's output for alarm to sound in the room of the fire.

### **Conclusions**

Wireless fire alarm is a very effective safety device; its application and use have been increasing day by day and in most cases radio transmission is used to send the signal. FM is used because of its superiority over other analog modulation schemes such as AM and PM. It shows good sound quality, better reception and more immune to noise and signal distortion. This project included a two transistor low power FM transmitter which gave us the opportunity to learn precisely the basic principle of frequency modulation, transmitter circuit, and various its components. While designing the smoke or fire detector we learn the various methods by which smoke or fire is detected and different components in the fire alarm circuit were discussed extensively as well.

### **References**

1. B.P. Lathi, "Modern Digital and Analog Communication Systems", 3<sup>rd</sup> Edition, Oxford University Press, New York, pp. 1-13, 151-189, 208-245.
2. Simon Ramo, J.R Whinnery and T. Duzer, "Fields and Waves in Communication Electronics", 2<sup>nd</sup> Edition, John Wiley and Sons, pp. 634-680.
3. V.K. Mehta, "Principles of Electronics", 3<sup>rd</sup> Edition, pp.386-406.
4. J. Millman, Christos C. Halkias, "Integrated Electronics", Sixth reprint 1994, Tata McGraw-Hill Edition, pp. 118-152, 223-280, 348-368, 483-497.
5. Robert L. Boylestad, Luis Nasheisky, "Electronic Devices and Circuit Theory", 8<sup>th</sup> Edition, Prentice-Hall of India, pp. 131-189, 355-426, 747-782, 821-850.
6. Samuel Y. Liao, "Microwave Devices and Circuits", 3rd Edition, Prentice-Hall, pp. 21-56.
7. Antennas from <http://en.wikipedia.org/wiki/antenna> page no. 1, 2 and 3.
8. Oscillators from <http://en.wikipedia.org/wiki/Hartlyoscillators> and Colpitts oscillators.
9. Wireless Fire Alarm from <http://en.wikipedia.org/wiki/wireless> fire alarm.
10. Smoke Detector from <http://en.wikipedia.org/wiki/smoke> detector page



## Social Awareness in William Blake's Poetry

Syed Ainal Huque\*

**Abstract:** The labour of that celebrant of energy and the prolific, William Blake, has generated an energetic and prolific diversity of interpretation. Though little known to his contemporaries and largely forgotten after his death, Blake's huge output of art and poetry inspired a range of twentieth-century readers, who drew from him or read into him principles democratic and aristocratic; libertarian and nationalist; activist and quietist; and Christian, Gnostic, and atheist. This article first reflects on how this difficult poet-artisan-prophet-artist fought against social injustices of the industrialized England. It then examines particular motifs, symbols, and beliefs in Blake, and the depictions of law, sin, liberty, and forgiveness.

**Keywords:** William Blake, nationalist, industrialized, atheist.

### Introduction

Many poems are created in order to entertain and amuse the reader. However, there are some that are created in order to point out something that is wrong with society. The poems "The Chimney Sweeper" from William Blake's *Songs of Innocence*, "The Chimney Sweeper" from William Blake's *Songs of Experience*, is an example of this type of poem. This poem uses the objective correlative in order to awaken in the reader an emotional response. Actually, the objective correlative is a means of communicating feeling through the use of images, situations, objects, and actions. Blake makes use of this objective correlative in order to arouse emotions of the reader about the social wrongs that are being depicted in their poems.

William Blake was a poet who was not very well recognized during his lifetime. It was not until his sixties when his work began to receive credit as leading a new literary movement in England at the time that was really triggered by William Wordsworth and Samuel Taylor Coleridge who were both much younger than Blake and of a superior social class. In his younger years, William Blake's poetry was written off as lunacy by most of his contemporaries, and although he is recognized now as the 'grandfather' of the Romantic period. That being said, the reason Blake is associated with Romanticism is because of his ardent support of the French Revolution and all forms of anti-establishment radicalism. Blake was an untiring rebel who verbally and poetically fought hard against all constrictions of his time--religious, social, sexual, and literary. His poems transmute clearly all the burring issues and events of his day and touch on issues such as the American War for Independence, the French Revolution, Colonialism and the expansion of Empire, Slavery, and finally the Industrial Revolution. Through Blake's work, the reader can deduce his passion and vision that social rebellion against these injustices would serve as an apocalyptic turning point in the history of humankind, destroying the old, decaying order of oppression and presaging the redemption of humanity.

---

\* Assistant Professor, Department of English, Dhaka International University, Dhaka, Bangladesh.

**Correspondence to:** Syed Ainal Huque, Email: ainalhuque19@gmail.com

The poems of William Blake reinterpret the spiritual history of the human race from the fall from Eden to the beginning of the French Revolution. Blake believed in the correspondence between the physical world and the spiritual world and used poetic metaphor to express these beliefs. In his poetry, we hear a man who looks for mankind to salvage his redemption from oppression through resurgence of imaginative life. The power of repression is a constant theme in Blake's poems and he articulates his belief in the titanic forces of revolt and the struggle for freedom against the guardians of tradition.

## **Historical Context**

A significant part of Blake's writing is the presentation of his own dominant ideologies and beliefs. He once stated: "I must create my own system or be enslaved by another man's." this truly defines the rebellious spirit of Blake. Similar to the notions examined at great length within the Songs of Innocence, Blake is strongly in favor of intuition, spontaneity, energy and imagination; characteristics he later equates to being man's path to divinity in "Auguries of Innocence". Yet another concern to reformist Blake was society's unwillingness to accept and recognize new ideas and opportunities for change.

William Blake began his writing career in the late eighteenth century, continuing right up to his death in 1827. This period, between his birth in 1757 and his death seventy years later, was a time of great social, political, philosophical and economic upheaval. One of the major alterations to traditional life was the emergence of large, industrial, over populated cities that accommodated for the large influx of people to metropolitan areas following the agricultural and industrial revolutions. The resulting society was one of oppression and poverty; a darker period of human history to which Blake was utterly disgusted. As a compassionate, moral man he despised the injustices and basic rights violations that had become a part of modern life. Consequently these social grievances became the basis of a large number of Blake's poems. "London", for instance, is one of Blake's more blatant attacks on such a society and its value system.

At the same time there was great concern and conflict within Britain's political spheres, regarding either Britain's participation in, or preparation for war throughout this entire period. The American War of Independence, in 1776 through to 1783, and the French Revolution over the sixteen years between 1789 to 1815 were valid indications of a failing political, social, economic and in some cases, moral polity. It was felt that the governments were unable to guarantee the safety and health of the mistreated citizenship and the 18th Century steadily became seen as a period of excess corruption, venality and lies. Consequently a number of courageous individuals stood up against the oligarchy, but to little success.

These inadequacies, however, were not simply limited to the realm of politics. At the time in which Blake was writing the church was hardly the virtuous institution we associate with religion today. It was not uncommon for the church to utilise vicious child labour, retain donated money and show little interest in the actual helping of the poor and needy. As a promoter of social justice and an extremely humane man, Blake was strongly opposed to the Christian church, an element that often comes through in his writing. He did not, however, refuse the existence of God. Instead he recognised an extremely unique, and arguably heretical belief that Christ, the

Son, represented all that is good and spiritual, while the Father, God, was a symbol of absolute power, terror and tyranny. It is possible to recognise Blake's interpretation of Christianity through his poetry. For instance in "The Lamb" Blake identifies the role of "the maker" not with God the father, but rather with Jesus, the Lamb of God.

Crucial to our understanding of William Blake, is the notion that he saw poetry and art as the avenue to social reform. Although throughout his life he demonstrated a passion for his work, Blake's writings were by no means purely recreational, but rather social critiques and doctrines, analysing issues within his contemporary society. The public response, however, was hardly auspicious and Blake, like many other pre-romantic writers, was ostracised from the literature and general community.

Another interesting element in Blake's poetry is the notion of contrast and opposition, he states: "Without contraries there is no progression. Attraction and Repulsion, Reason and Energy, Love and Hate, all are necessary to human existence." He argued that all things have a natural contrast, in the case of Blake's poems this is justified by the plurality of his work; often publishing two poems on the same idea, but from different perspectives. It is generally regarded that Blake's greatest poetic achievements are those of the Songs of Innocence and the Songs of Experience, collections of poems between which there is often an obvious contrast between a similarly titled poems, or poems dealing with a similar issue. "The Sick Rose" compared to "The Blossom" and "Holy Thursday" (one from the Songs of Innocence and Experience, respectively) are the classic examples of such contrary works.

### **Social Awareness**

William Blake has gained notoriety as both a poet and an artist. In his widely praised work, Songs of Innocence and Experience, he exhibits his talent for both. The concepts of innocence and experience are two of Blake's most frequented themes. The title page for the first part of Songs of Innocence and Experience exhibits a relief etching of Blake's interpretation of innocence. It shows a mother sitting with her children, garden imagery, and children playing. It is a happy, hopeful scene. This is in stark contrast with the etching for the second part of Songs of Innocence and Experience, which depicts his dire interpretation of experience. In this relief, Blake sets a scene of death, sorrow, and spirits hovering above it all. These two etchings set the tone for the poems that follow them.

However, William Blake was not simply an artist with a pretty turn of phrase. Blake was a culture critic. He was a preacher against social ills. He strove to illuminate the issues of poverty, child labor, and the hypocrisy of the upper English classes, and to evoke compassion and change in English society. "Holy Thursday," "London," "The Chimney Sweeper," and "The Human Abstract" are a sampling of Blake's socially conscious poetry. Only through understanding of the history of England's working class can we truly understand and appreciate Blake's artistic and literary work.

From the seventeen hundreds through the early nineteen hundreds England suffered deplorable living and working conditions. As early as 1688, Gregory King found that 364,000 laborers and servants made only fifteen pounds a year. That was twenty-five pounds a year under the poverty line. "Four hundred thousand cottagers and paupers were on six pounds, ten shillings a year. His

findings concluded that the top 1.2 percent income level of the population owned 14.1 percent of the national income, and the bottom 67.1 percent owned a mere 29.9 percent of it”.<sup>1</sup>

The Poor Law of 1601 stated that it was the duty of the parish to provide for the maintenance of the poor. However, the bourgeoisie reformed the law in 1833 because they thought the law was being abused. Relief fosters laziness and increase of surplus population. Poverty became a crime, and it was visited with stiff penalties so as to warn others against it. The New Poor Law Commissioner described the bourgeoisie’s position on the poor: “We grant you a right to exist, but only exist; the right to multiply you have not, nor the right to exist as befits human beings. Live you shall, but as an awful warning to all those who might have inducements to become superfluous”.<sup>2</sup> The reformed Poor law stated that relief would have strings attached to accept relief would mean loss of liberty by hard labor in a workhouse.

Atrocities like these prompted Blake to write his poems. Unlike many in English society, Blake could not turn a blind eye to the pain of the working class. Instead, he attempted to shed a light on the ugliness of poverty, in an effort to rally people to change the system. In his poem, “Holy Thursday,” the line, “Is this a holy thing to see/ In a rich and fruitful land/ Babes reduced to misery/ fed with a cold and userous hand,” is an allusion to England. England was an extremely rich and influential country, yet its children were little more than miserable slaves. Blake goes on to say that with so many poor children, England was truly a land of poverty.<sup>3</sup>

Blake furthers his theme of the misery of the working class in his poem, “London.” He notes the pain of his fellow man in the last two lines of the first stanza, “And mark in every face I meet/ Marks of weakness/ marks of woe.” He mentions the poorer classes of Londoners, the chimneysweepers and soldiers, as sighing and crying. He evokes a sense of social decay and disease in his line, “How the youthful Harlot’s curse” and ends the poem hopelessly with, “And blights with plagues the Marriage hearse.” This poem gives a bleak view of England. Many in the upper classes, especially the bourgeoisie, did not want to see the social problems that were causing decay in the majority of the population. In this poem, Blake forces the reader to see the impurity and disease that was festering in England’s greatest city, London.

Life was considered cheap. The workhouses were run for profit and manufactured many different products. It was far less expensive for industries to use people, than new technology, because labor was so abundant and cheap. Other nations cleaned chimney flues with brushes; England with climbing boys. Working conditions were filthy, dangerous, grueling, and all endured for slave wages. Factory labour was extremely long, often twelve or thirteen hours a day, six days a week. Factories were replacing male labor with female and child labor, because they could pay women and children less than they were paying men, yet made them work even longer hours than men, because they were not organized to fight against the unreasonable conditions. Dean Tucker wrote about the workers in the cloth trade as analogous to slaves rowing on a slave ship. Apprentices likewise were often little better than galley-slaves. This trend of harder work for less remuneration took a devastating toll on family incomes in English towns. To add to families’ struggles, grain prices climbed exorbitantly from 1783-1800, and the cost of living almost doubled between 1770 and 1795, and went up by as much again by 1800.

This epidemic indigence put children to work at an early age. Blake's principal criticism of English employing society was the nearly universal use of child labor. The bourgeoisie claimed, "If we do not employ the children in the mills, they are only left under conditions unfavorable to their development".<sup>4</sup> But they do not say how mill and factory work is more favorable to child development than unemployment. On the contrary, workhouses, mills, and factories were teeming with overwork, disease, and torturous neglect. Children of five years of age (especially boys) began their manual labor careers as chimney sweeps. By the age of nine, boys and girls alike, in the working class, began working in factories and mills for fourteen to sixteen hours a day. Those even more unfortunate were employed under the night shift and never saw daylight.

It was not just the grueling hours that made the workhouses and factories abusive to children. Children could be sent to work hundreds of miles away from their families, never to see their parents again. The overseers were permitted to flog and mistreat the children. Often the work itself had a crippling effect on their bodies. Mutilations were common, especially in textile factory machine accidents. Death rates in the workhouses were always considerably high. "The death-rate in the workhouse of St. George's Middlesex, was 100 per cent. Out of 2,339 children received into London workhouses in the five years after 1750, only 168 were alive in 1755".<sup>5</sup> Blake accused the bourgeoisie government, parents, and even God for these deaths, but no one answered Blake's accusation of the slaughter of innocents.

Children were Blake's chief concern. His poem "The Chimney Sweeper" directly addresses the misery and fate of the child laborer. It appears in two different versions, one in the innocence part of Songs of Innocence and Experience and the other in the experience section of the volume. The "innocent" version of the poem is sad, but hopeful. It tells the story of a very young chimney sweep and how his life barely dodges death. With the lines, "And my father sold me while yet my tongue Could scarcely cry weep! weep! weep! weep! So your chimneys I sweep & in soot I sleep," Blake tells the common story of the working class young. The line, "weep! weep! weep! weep!" refers to the chimney sweeps' cry of "Sweep! Sweep!" to drum up business in English towns. Blake uses it to illustrate how young the working class of England had become the child is too young to properly pronounce, sweep. Even though he writes stark lines about the deaths of the young chimney sweepers, "That thousands of sweepers, Dick, Joe, Ned, and Jack, Were all of them lock'd up in coffins of black," he contrasts these sad lines with a politically correct, yet hopeful ending, "So if all do their duty, they need not fear harm".<sup>6</sup>

The experience version of "The Chimney Sweeper" is far less hopeful, and this helps to convey Blake's point that experience destroys the innocence of children. In this version, the sweeper's cry of "weep! weep!" is not only the childish pronunciation of sweep, but also represents notes of woe. The second stanza discusses the child's happiness playing in the heath, and how his parents stole his childhood from him. "They clothed me in tAhe clothes of death, And taught me to sing the notes of woe." Both poems speak to the issue of children being sold into labor at a very early age. Blake clearly was opposed to child labor and wished to evoke the misery of the children robbed of their innocence and childhood.

As a last example of Blake's social consciousness, his poem, "The Human Abstract" criticizes the hypocrisy of England's upper class. This poem makes clear, what many in English politics (such as Malthus and his followers) believed. They claimed that poverty was necessary for social

and economic stability. This poem is a scathing evaluation of such people and beliefs. The lines, “Then Cruelty knits a snare, And spreads his bait with care” and “And Mercy no more could be, If all were as happy as we” speak directly to the revisers of The Poor Law, who condemned poverty as a crime and made it punishable through starvation and slave labor in the workhouses. Engels agrees with Blake’s criticism of the bourgeoisie with his question, “How can one be otherwise than filled with wrath and resentment against a class which boasts of philanthropy and self-sacrifice, while its one object is to fill its purse a tout prix?” Blake says, in this poem, that the tree that bears the fruit of deceit may be found in the human brain, and this may be applied to the way the bourgeoisie claimed humanitarianism and mercy with their poverty laws and workhouses, when truly they were cruel, self-profiting, and despicable.

William Blake wrote poetry with a purpose. He decried the government and English society in his art. He spoke the truth and related reality, when many people in England wanted to maintain their ignorance. He used poetry as a medium to direct attention to the social atrocities that deeply concerned him and plagued England. To read Blake’s poetry as mere rhythm and rhyme, as a simple recreational reading, is to completely miss the author’s point and purpose. Blake’s poetry was an editorial on England. He spoke for those that could not speak for themselves. He defended the young and the poverty stricken. He criticized the lawmakers and bourgeoisie. William Blake was a culture critic in a time that was desperately deserving of severe criticism.

### **William Blake’s Relevance to the Modern World**

Blake lived during a time of intense social change. The American Revolution, the French Revolution, and the Industrial Revolution all happened during his lifetime. These changes gave Blake a chance to see one of the most dramatic stages in the transformation of the Western world from a somewhat feudal, agricultural society to an industrial society where philosophers and political thinkers such as Locke, Franklin, and Paine championed the rights of the individual. Some of these changes had Blake’s approval; others did not.

One example of Blake’s disapproval of changes that happened in his time comes in his poem “London,” from his work *Songs of Experience*. In “London,” which has been described as summing up many implications of *Songs of Experience*, Blake describes the woes that the Industrial Revolution and the breaking of the common man’s ties to the land have brought upon him. For instance, the narrator in “London” describes both the Thames and the city streets as chartered, or controlled by commercial interests; he refers to mind-forged manacles; he relates that every man’s face contains “Marks of weakness, marks of woe”; and he discusses the “every cry of every Man” and “every Infant’s cry of fear.” He connects marriage and death by referring to a marriage hearse and describes it as blighted with plague. He also talks about “the hapless Soldier’s sigh” and the “youthful Harlot’s curse” and describes blackening Churches and palaces running with blood.

“London” and many of Blake’s other works dealing with a similar theme, particularly those from the *Songs of Experience*, strike a particular nerve for those who are living in a society where the cost of living compared with income is steadily increasing, where AIDS, Ebola, and other new and frightening diseases are becoming increasingly common, and where the public is becoming increasingly disillusioned about the reliability and trustworthiness of politicians. These works

resonate for a generation which has to deal with exponentially increasing population problems and with rapidly increasing demands on our immigration facilities and resources. They strike a special chord with a nation that, due to the aforementioned problems, the rise of violent crime, and other considerations, is rapidly desensitizing itself to the marks of weakness, marks of woe that we are becoming accustomed to seeing on the faces of passers-by on the street.

Blake also attacked conventional religion. In *The Marriage of Heaven and Hell* he wrote “Prisons are built with stones of Law, Brothels with bricks of Religion” and “As the caterpillar chooses the fairest leaves to lay her eggs on, so the priest lays his curse on the fairest joys” (Proverbs 19; Proverbs 20). Rather than accepting a traditional religion from an organized church, Blake designed his own mythology based primarily upon the Bible and Greek mythology to accompany his personal, revealed religion. Blake’s personal religion was an outgrowth of his search for the Everlasting Gospel, which he believed to be the original, pre-Jesus revelation which Jesus preached. As Blake said, “all had originally one language and one religion: this was the religion of Jesus, the everlasting Gospel. Antiquity preaches the Gospel of Jesus”.<sup>7</sup> Blake’s religion was based upon the joy of man, which he believed glorified God.

One of Blake’s strongest objections to orthodox Christianity is that it encourages the suppression of natural desires and discourages earthly joy; in *A Vision of the Last Judgment*, Blake says that men are admitted into Heaven not because they have curbed and governed their passions or have no passions, but because they have cultivated their understandings.<sup>8</sup> The Treasures of Heaven are not negations of passion, but Realities of Intellect, from which all the passions emanate uncurbed in their eternal glory. Blake also believes that the religion of this world is actually the worship of the entity that St. Paul calls “the god of this world” in II Corinthians 4:4: Satan. It should be noted here that Blake does not conceive of Satan as an incarnate horned quasi-deity, but rather as Error and the “State of Death”;<sup>9</sup> Blake also explicitly says that Satan is not a human existence. Blake believes that orthodox Christians, in part because of their denial of earthly joy, are actually worshipping Satan, which is to say that they are in error.

## Conclusion

Blake lived in a period of aggressive British colonialism, slavery, social casting, Revolutionary change in America and Europe, as well as the beginning of the Industrial Revolution. Being a member of the lower class, an uneducated artist in the formal sense of the term, although Blake was clearly quite intelligent, and considered by many to be an inferior poet bordering madness, Blake experienced firsthand the struggles of oppression. Using words and illustrations, Blake fought back against his countrymen, political leaders, and religious principles. The theme of the repressed is the easiest to identify and extract from Blake’s poetry. Most all of his work will feature a wearisome protagonist who is attempting to revolt against some greater being, whether it be politically, religious, or even the shackles of love and marriage. Many times, this theme is represented in the form of mythology, literary allusion, and the personification of natural objects. Frustrated with a long period of repression in Europe, Blake felt it was time for the people to rise and fight back, and that a political and philosophical cleansing was not only a positive part to the progression of mankind and evolution of societies, but that it was as natural as the rotation of the earth, the changing of the seasons, and the maturity of human.

He criticises the corruption of civilization by the power of Reason, whose mind-forged manacles have restricted every natural joy into a terrible agony. The street-cries of the chimney-weepers are accusations against the Church; and the death-sigh of the soldier is a stain upon State. Love itself, when so bound, makes the marriage-bed a diseases-blighted hearse. His poem is not only a protest but also a picture of a mental state.

We can sum up that Blake, who was a great believer in natural impulses, hated all kinds of restraints. He condemns all those who exercise restraints upon others because God has created human beings with the same right. Therefore he censures any tyrant and oppression to mankind. Blake gives attribute to Urizen, who symbolizes Reason in Blake's later poetry, as all negative such as jealousy, fearfulness, cruelty, secrecy, and hatred of life and of joy.

## References

1. Porter, Roy. 1991 **English Society in the Eighteenth Century**. London: Penguin Books,
2. Engels, Friedrich. 1987 **The Condition of the Working Class in England**. Rev. ed. London: Penguin Classics,
3. H. Hagstrom, Jean. 1964 **William Blake. Poet and Painter. An introduction to the illuminated verse**. University of Chicago,
4. Viscomi, Joseph. 1993 **Blake and the Idea of the Book**. Princeton University Press,
5. Davis, Michael. **William Blake. 1977 A new kind of man**. University of California, Berkeley,
6. Wilson, Mona. 1927 **The Life of William Blake**. London: The Nonesuch Press,
7. Greenblatt, Stephen. 2006 **The Norton Anthology of English Literature**. New York: W. W. Norton & Company,
8. Harmon, William. 2006 **A Handbook to Literature**. New Jersey: Pearson Education,



## **John Keats' Personal Life and Literary Contemplation in His Letters**

**Dr. Md. Shah Alam Chowdhury\***

**Abstract:** This article is an attempt to show the intellectual ability of John Keats which has been focused in his letters. John Keats is one of the major romantic poets in English Literature. His artistic views are reflected in his letters. Literature and society are closely related. John Keats talks about his personal life, contemporary society as well as tragedies of his life in these letters.

**Key Words:** *Letters, Romanticism, Personal life, Poetic Contemplation, Relationship.*

### **Introduction**

John Keats, a very short-lived romantic poet, has written numerous letters which help us to rediscover him and his poetic excellence. The letters of Keats to his brothers, friends, publishers and near-dear ones are as significant as his poems because they reflect or put light upon his real self. i.e his personality. These letters are in fact, the record of his eventful life, works and the repository of his poetic and philosophical ideas and thoughts.

Keats' letters are as much of an interest as his poems. His letters reveal his striving to gain knowledge and his understanding of human condition and the nature of suffering. In fact, these letters are an attempt to explore John Keats in a new dimension. These are also an attempt to study John's deep insight into human life and spiritual musings. The letters provide us both a generous self-revelation of a man's inner self as well as his poetic thought. These letters, once again, emphasize the extent to which poetry was an integral part of Keats' life and the depth to which it was felt and lived. His development as a poet was rapid, particular and individual and in his letters it is articulated in the bursts of energetic and critical self-analysis. These letters establish him as an affectionate brother, reliable and faithful friend, a passionate lover and above all a powerful literary critic.<sup>1</sup>

---

\*Associate Professor, Department of English, Dhaka International University, Dhaka, Bangladesh.

**Correspondence to:** Dr. Shah Alam Chowdhury, E-mail: shahjabeen2010@gmail.com

### **Philosophy of John Keats**

Keats's letters are full with variety of subjects. The world and its surrounding in which John Keats inhabited is fully reflected in his letters. Moreover, his letters are loaded with his strong thought of beauty, imagination, love, friendship and creative process. In the letters Keats has written about the merits of other poets like Milton, Wordsworth and Shakespeare. From his short but eventful life Keats has built up for himself a personal store of reflections and ideas; his intellectual ambition is high; he realizes what is lacking in his nature and is determined to acquire a philosophy. Through letters we find his developed notions of poetry and his own aim as a poet. These letters are not merely invaluable clues to our understanding of the working of Keats' genius; they are also important documents in the history of literary criticism.

### **Romanticism and John Keats**

The Romantics were ambivalent toward the 'real' social world around them. They were often politically and socially involved but at the same time they began to distance themselves from the public. Keats' letters bear the significant emblems of his mental state, love, frustration, unhappiness and mental agony. In his poems we get the note that being dissatisfied with the practical world he tries to escape into the ideal and being disappointed in his mental flight, he returns to the real world. This kind of perplexity, suffering, and happiness he has directly reflected in his letter where the voice of the poet is very much realistic and honest. His every letter holds a strong literary significance being colored with deep imagination and emotion. John Keats has nurtured the genuine characteristics of romanticism. It is also said that English Romanticism attains in Keats the final stage of its progress. The letters are glaring example of his romantic tradition.

### **Keats' family life as revealed in his letters**

The letters of John Keats introduce the readers with his personal life. His life was full of agonies and it is best described in a letter written to his friend Reynolds: "*The world is full of misery, heart break, pain, sickness and oppression.*" His sufferings deepened when his mother remarried soon after the death of his father. His mother left her children in a helpless condition and also left behind an inescapable, fatal disease called tuberculosis which Keats and his brother Tom inherited. From some of his private letters we find how tenderly Keats nurtured feelings of love, sympathy and affection for his sister and brothers. From his own words we discover him as an affectionate brother. Though he, himself was unhappy, Keats

was sincere to the well being of his family members. His tenderly feelings for his brother George are manifested in a letter written to Bailey on June 10, 1810. Keats writes:

*My love for my brothers from the early loss of our parents and even from earlier misfortunes has grown into an affection passing the love of women.*

Keats was almost obsessed with the wellbeing of his sister Fanny, who was the youngest of all and who suffered from the oppressive guardianship of Mr. Abbey after the untimely and accidental death of their parents. In a letter Keats wrote:

*"Your welfare is a delight to me which I cannot express. The moon is now shining full and brilliant; she is the same to me in the matter that you are in spirit... I have a tenderness for you and an admiration which I feel to be as great and more chaste than I can have for any woman in the world." Keats wrote her regularly a series of letters, roughly every fortnight.<sup>2</sup>*

### **Keats' attitude towards human life**

Beside his sympathy for fellow beings, Keats had a deep thought over human life. He had gone through the bitter and stark realities of everyday life. In the letters Keats has recorded his day to day life. He has linked life to every day's every happening and developed a strong philosophy of life. In a letter to J.H Reynolds on May 03, 1818, Keats wrote:

*"I compare human life to a large Mansion of Many Apartments, two of which I can only describe, the doors of the rest being as yet shut upon me—The first we step into we call the infant or thoughtless Chamber, in which we remain as long as we do not think—We remain there a long while, and notwithstanding the doors of the second Chamber remain wide open, showing a bright appearance, we care not to hasten to it; but are at length imperceptibly impelled by the awakening of the thinking principle—within us—we no sooner get into the second Chamber, which I shall call the Chamber of Maiden-Thought, than we become intoxicated with the light and the atmosphere, we see nothing but pleasant wonders, and think of delaying there for ever in delight: However among the effects this breathing is father of is that tremendous one of sharpening one's vision into the heart and nature of Man—of convincing ones nerves that the World is full of Misery and Heratbreak, Pain, Sickness, and oppression—whereby This Chamber of Maiden Thought becomes gradually darken'd and at the same time on all sides of it many doors are set open—but all dark—all leading to dark passages—We see not the balance of good and evil. We are in a Mist—We are now in that state—We feel the "burden of the Mystery,"<sup>3</sup>*

### Keats' Poetic Contemplation

In fact, through this letter he explored life with all its truth, with all its realities. As a romantic Keats lived and believed in the world of imagination He regarded it as true as the everyday one. To him, imaginative world is a great source of knowledge and poetry. Throughout his life, he longed for a “world of sensations” in which he might gain deeper awareness, which in turn he fed into his poetry. He had a strong faith in the truth of imagination. In a letter written to his friend Benjamin Bailey on 22<sup>nd</sup> November 1817, Keats argues for “a life of sensations rather than of thoughts”:

*“But I am running my head into a Subject which I am certain I could not do justice to under five years study and 3 vols octavo—and moreover long to be talking about the Imagination—I am certain of nothing but of the holiness of the Heart’s affections and the truth of Imagination—What the imagination seizes as Beauty must be truth—whether it existed before or not—for I have the same Idea of all our Passions as of Love they are all in their sublime, creative of essential Beauty—In a Word, you may know my favorite Speculation by my first Book and the little song I sent in my last—which is a representation from the fancy of the probable mode of operating in these Matters—The Imagination may be compared to Adam’s dream—he awoke and found it truth. I am the more zealous in this affair, because I have never yet been able to perceive how anything can be known for truth by consequitive reasoning—and yet it must be—Can it be that even the greatest Philosopher ever arrived at his goal without putting aside numerous objections—However it may be, O for a Life of Sensations rather than of Thoughts! It is ‘a Vision in the form of Youth’ a Shadow of reality to come—and this consideration has further convinced me for it has come as auxiliary to another favorite Speculation of mine, that we shall enjoy ourselves here after by having what we called happiness on Earth repeated in a finer tone and so repeated—And yet such a fate can only befall those who delight in sensation rather than hunger as you do after Truth—Adam’s dream will do here and seems to be a conviction that Imagination and its empyreal reflection is the same as human Life and its spiritual repetition. But as I was saying—the simple imaginative Mind may have its rewards in the repetition of its own silent Working coming continually on the spirit with a fine suddenness—to compare great things with small—have you never by being surprised with an old Melody—in a delicious place—by a delicious voice, felt over again your very speculations and surmises at the time it first operated on your soul—do you not remember forming to yourself the singer’s face more beautiful that it was possible and yet with the elevation of the Moment you did not think so—even then you were mounted on the Wings of Imagination so high—that the Prototype must be here after—that delicious face you will see—What a time! I am continually running away from the subject—sure this cannot be exactly the case with a complex Mind—one that is imaginative and at the same time careful of its fruits—who would exist partly on sensation partly on thought—to whom it is necessary that years should bring the philosophic Mind—such an one I consider your’s and therefore it is necessary to your eternal Happiness that you not only drink this old Wine of Heaven which I shall call the redigestion of our most ethereal Musings on Earth; but also increase in knowledge and know all things”.*<sup>4</sup>

Some of Keats' letters explore his poetic ideas. 'Negative Capability' is his most remarkable poetic theory. In the letters to George and Tom Keats in 21 and 27 December, 1817, he defined negative capability as "when man is capable of being in uncertainties, mysteries, doubts, without any irritable reaching after fact and reason." His theory is profound and timeless. He was one of those courageous poets who dared to express uncertainties, fears and doubts and used them to explore the deepest recesses of soul. In fact, poetry is shaped by a writer's personal interests and beliefs, objectivity. However, the poet is receptive to 'uncertainties' of experience, like death and sickness. He believed that Shakespeare was a master of seeing the truth in all the honesty of its contradictions:

*"My dear Brother*

*I must crave your pardon for not having written ere this .[T]he excellence of every Art is its intensity, capable of making all disagreeables evaporate, from their being in close relationship with Beauty & Truth—Examine King Lear & you will find this exemplified throughout; but in this picture we have unpleasantness without any momentous depth of speculation excited, in which to bury its repulsiveness—The picture is larger than Christ rejected—I dined with Haydon the sun day after you left, & had a very pleasant day, I dined too (for I have been out too much lately) with Horace Smith & met his two brothers with Hill & Kingston & one Du Bois, they only served to convince me, how superior humour is to wit in respect to enjoyment—These men say things which make one start, without making one feel, they are all alike; their manners are alike; they all know fashionables; they have a mannerism in their very eating & drinking, in their mere handling a Decanter—They talked of Kean & his low company—Would I were with that company instead of yours said I to myself! I know such like acquaintance will never do for me & yet I am going to Reynolds, on wednesday—Brown & Dilke walked with me & back from the Christmas pantomime. I had not a dispute but a disquisition with Dilke, on various subjects; several things dovetailed in my mind, & at once it struck me, what quality went to form a Man of Achievement especially in Literature & which Shakespeare possessed so enormously—I mean Negative Capability, that is when man is capable of being in uncertainties, Mysteries, doubts, without any irritable reaching after fact & reason—Coleridge, for instance, would let go by a fine isolated verisimilitude caught from the Penetrarium of mystery, from being incapable of remaining content with half knowledge. This pursued through Volumes would perhaps take us no further than this, that with a great poet the sense of Beauty overcomes every other consideration, or rather obliterates all consideration.'*<sup>5</sup>

Keats was a keen reader of poetry. He had an insatiable thirst for poetic knowledge. Poetry was the driving force of Keats' short life. Poetry was to Keats a spontaneous outburst of emotion. It comes automatically to the poet: no force can produce poetry. In a letter to John Taylor on February 27, 1818, Keats noted thus: "If poetry comes not as naturally as the

leaves come to a tree it had better not come at all." The poet started his career as an apprentice to a surgeon but knives, forceps, plasters and tablets could not hold him back. He left the job and became an ardent reader of poetry. To him poetry was life and life was poetry. In a letter to Reynolds, written on April 18, 1817, Keats admitted: "I find that I cannot exist without poetry, without eternal poetry. Half the day will not do---the whole of it."

As a critic he recognized the genius of Shakespeare and loved to read passages from his plays whenever he found time. The poetic sensibility and critical insight are happily combined in him. In a letter to a fellow-poet named Haydon, Keats wrote: "I am very near agreeing with Hazlitt that Shakespeare is enough for us." Appreciating William Wordsworth, he wrote to Reynolds in 1818: "He is a genius and superior to us in so far as he can make discoveries and shed light in them. Here I think Wordsworth is deeper than Milton." Keats could sharply perceive the distinctive poetic features of John Milton about whom he wrote in the same letter: "He did not think with the human heart as Wordsworth has done. Yet Milton as a philosopher had surely as great power as Wordsworth."

Again, Keats has described in details on the aims of poetry in his letters. Keats' letters explore him as a profound and intelligent thinker of poetry who offers his distinctive view regarding the nature and function of poetry. As an earnest devotee of poetry, he loved poetry for its own sake and not for its message. He believed that poetry should purely be the expression of the poet's impressions of nature; it should be a thing of beauty. Poetry should delight people with its beauty and elevate them with truth. His letter to J.H. Reynolds on 3 February 1818 is a remarkable document of his poetic thought:

*"We hate poetry that has a palpable design upon us—and if we do not agree, seems to put its hand in its breeches pocket. Poetry should be great & unobtrusive, a thing which enters into one's soul, and does not startle it or amaze it with itself but with its subject.—How beautiful are the retired flowers! how would they lose their beauty were they to throng into the highway crying out, 'admire me I am a violet! dote upon me I am a primrose! Modern poets differ from the Elizabethans in this. Each of the moderns like an Elector of Hanover governs his petty state, & knows how many straws are swept daily from the Causeways in all his dominions & has a continual itching that all the Housewives should have their coppers well scoured: the antients were Emperors of vast Provinces, they had only heard of the remote ones and scarcely cared to visit them.—I will cut all this—I will have no more of Wordsworth or Hunt in particular—Why should we be of the tribe of Manasseh when we can wander with Esau? Why should we kick against the Pricks, when we can walk on Roses? Why should we be owls, when we can be Eagles?'"<sup>6</sup>*

The letters of John Keats are running document of his poetic thought. Through letters he has explored his views and ideas on poetry. This great romantic thinks that poetry should be pure art which should not be dominated or guided by any single creed or philosophy. He loved the principles of beauty in all things and his aim in poetry was to express that poetry which he loved so well. He opines that the beauty of poetry should be flourished spontaneously. He reveals in his poetry the hidden delights of nature, the true spirit of antiquity. In a letter to John Taylor, on 27<sup>th</sup> February, 1818, Keats says,

*“In Poetry I have a few Axioms, and you will see how far I am from their Centre. 1st I think Poetry should surprise by a fine excess and not by Singularity—it should strike the Reader as a wording of his own highest thoughts, and appear almost a Remembrance—and Its touches of Beauty should never be half way thereby making the reader breathless instead of content: the rise, the progress, the setting of imagery should like the Sun come natural too him—shine over him and set soberly although in magnificence leaving him in the Luxury of twilight—but it is easier to think what Poetry should be than to write it—and this leads me on to another axiom. That if Poetry comes not as naturally as the Leaves to a tree it had better not come at all.”*<sup>7</sup>

Keats has strong observation regarding a poet also. A pure poet does not burden his poetry with any didacticism, he also does not permit his own self to intrude into it. Pure poetry is entirely impersonal, it has no deliberate message to convey, its one and sole aim is to create beauty wherever it exists. It is for this reason that his work is inspired not by his own personality but by the world of things and men outside him. External impression makes him lose, for the moment, his personal identity and he renders them so effectively in his poetry. He luxuriates in the joy of the nightingale’s song so completely because his identity is merged, for the time being with that of the bird. He shared with Richard Woodhouse saying, *“A poet is the most unpoetical of anything in existence; because he has no Identity- he is continually in for- and filling some other Body- The Sun, the Moon, the Sea and Men and Women who are creatures of impulse are poetical and have about them an unchangeable attribute.....”*

### **Keats in Romantic Relationship**

Some of Keats’s private letters provide information that he had developed strong fascination for three women. They were Jane Cox, Mrs. Isabella Jones and Fanny Brawne. John Keats had some weakness towards Jane Cox. He admitted that he liked her but did not have any genuine love affair with her. In a letter of October 14, 1818, Keats wrote to George: *“I forget myself entirely because I live in her. You will by this time think I am in love with her; so before I go any further I will tell you I am not.”* Keats also had feelings for Isabella Jones,

whom he had met by chance. A deep relationship developed between them but that seemed to be based on mere friendship. In a letter Keats said: *"I expect to pass some pleasant hours with her now and then... have no Libidinous thought about her."* But it was Fanny Brawne whom Keats loved with all his heart and who happened to be his close neighbour. Fanny was like an indispensable part of his life. Unfortunately Fanny did not reciprocate his feelings. Fanny led almost an anarchic life, and this caused mental suffering for Keats. In a letter Keats said: *"She is not seventeen.... but she is ignorant... monstrous in her behavior, flying out in directions."* The poet had a perpetual sense of belonging to her and sought to be reassured that Fanny really belonged to him.

Retirees and loneliness grasped the poet seriously but he could hardly escape it. He longed for a companion who could share equally his joys and sufferings. The poet wrote in a letter: *"The hawk wants a mate so does the man.....they both want a nest and they both set about one same in the manner."* During the last stage of his life, especially when his disease took a serious turn, the poet craved for the constant company of his beloved. But Fanny chose to remain alienated from him and remained occupied with the self-oriented activities. In 1820 Keats wrote to Fanny: *"It is certain I shall never recover if I am to be so long separated from you...I am literally worn to death which seems my only recourse."*

The complex relationship with Fanny Brawne and its shocking result accelerated the pathos of his life. He had a critical attitude towards womankind, but still he loved Fanny Brawne intensely, passionately, devotedly and sincerely. Keats' sense of belonging to Fanny was simply overwhelming and he wanted to see that she had given up all her moral irregularities that accelerated the process of his untimely death. What was sport to Fanny, was death to Keats. In the same letter Keats wrote with a bleeding heart:

*"If you still behave in the dancing rooms and other societies as I have seen you ... I do not want to live ... if you have done so I wish this coming night may be my last. I cannot live without you and not only you but chaste you and virtuous you ... be serious. Love is not a plaything."*<sup>8</sup>

Keats' letters reveal that he was of a rather suspicious and pessimistic bent of mind. In one of his letters he writes to his friend Baily, *"You have all your life believed everybody; I have suspected everybody"*. In another letter he writes, *"I dislike mankind in general"* and adds *"If ever there was a person born without the faculty of hoping, I am he."* Here there is no doubt that ill health, disease and hopeless love did much to aggravate the morbidity and gloom of his nature. But it is also a fact that he had a number of affectionate and devoted friends who spoke highly of him in life, liked his company and cherished his memory after his death.



## Conclusion

The letters of John Keats are strikingly compounded with elements that emerge from his own poetic temperament. The artistic range of the letters is wider and the treatment of life in these letters is marked by the more searching pathos, the more sensitive outburst of thought which belong to Keats as a partaker in the romantic renaissance of feeling. The literary contribution by introducing an autobiographic and personal elements, bears the synthesis of emotion, attitude and literary viewpoint of the poet. Keats was especially drawn to a field which abounded in romantic elements and the chief service to letters in which he shared his thought create a space for us to explore him employing the best illuminating intuitions. The intensity of emotion and accuracy of perception with which he colored his poetic career cannot be evaluated properly only in terms of his poetic development. The analysis of his letters throws light to know Keats. The letters present before us the faithful picture of his life as well as his psychological insight that constitute an individual world of Keats with permanent literary significance.

## References

1. Linda, Cookson; Bryan, Loughrey. *Critical Essays on Keats's Poems and Letters*, Longman Literature Guides.
2. David, Daiches. 2006 *The Romantics to the Present day, A Critical History of English Literature*, Volume iv, Reprinted
3. Robert, Gittings. 1970 *The Letters of John Keats*, (ed.) Oxford,
4. Legouis, Cazamian. 2004 *History of English Literature*, Macmillan India Ltd.
5. Syed Naquib, Muslim. 2010 *The letters of John Keats* published in [www.thedailystar.net/newDesign/news-details.php?nid=144](http://www.thedailystar.net/newDesign/news-details.php?nid=144)
6. Andrew, Sanders. 2006 *The Short Oxford History of English Literature*, Third Edition, Oxford University Press,
7. Grant, Scott. 2002 *Selected Letters of John Keats: Based on the Texts of Hyder Edward Rollins*. Harvard University Press, London,
8. *Full text of 2013 "Letters of John Keats to his family and friends*. [www.enotes.com/letters-john-keats-salem/letters-john-ke...](http://www.enotes.com/letters-john-keats-salem/letters-john-ke...)retrieved.

## Spiritualism in W B Yeats' Poetry

Mili Rahman\*

**Abstract:** Spiritualism ushers W. B. Yeats to the development of a unique, spiritual and philosophical life. Yeats had rejected Christianity early in his life, but his lifelong study of mythology, theosophy, spiritualism, philosophy, and the occult reveal his deep curiosity in the divine and its interaction with humanity. Throughout his life, he formed a compound system of spirituality, using the image of intertwining gyres to outline the advance and revival of the soul. Spirituality takes many shapes in his poetry. Sometimes it appears literally as in *Leda and the Swan*, sometimes abstractly in *The Second Coming*. In other poems, the spirituality is gestured as the celestial sense in the Byzantine mosaics in *Sailing to Byzantium*. Whatever shape it takes, spiritualism indicates the role of fate in resolving the course of mysterious life journey.

**Key Words:** *Spiritualism, The Sages, Rough Beast, Mysticism, Gyre, Anti Christ, Soul.*

### Introduction

The poetry of W. B. Yeats is full of spiritual essentials, symbols, subject matters and motifs. His spiritual philosophy attracts the readers and poem lovers for his extra ordinary thoughts and ideas. This Irish poet lost his Christian faith as a boy, but he was a man of profoundly religious disposition. A passionate pastor of life on earth, he nevertheless upheld a lifelong search for a world beyond. This hastened him to various kinds of mysticism, to legends, theosophy, spiritualism, and Neo-Platonism— not in any stringent chronological order, for he kept returning to and reworking earlier aspects of his thought. In fact his poetry was a display of his passion for Irish mythology and folklore mixed with spirituality and the occult.

The human experience, the corporal, emotional and spiritual elements of life, is inextricably related with the versatile notion of longing. Indeed, longing, as one of the most powerful elements of human sentiment, reflects as a central concern in Yeats' life and his poetry. His poetry, ranging over numerous decades, ideological factions and poetic forms, can be seen as a personal expedition to accomplish his desires. His early poems circle fanatically around desire and its objects. They depict a kind of desire that cannot be content, but feeds off its nuisance. His later poems, on the other hand, depict desire as an eternal, disembodied force that sweeps over humanity and possesses an enduring relevance. W. B. Yeats looks for a theory of the essence of spirit as spirit, a theory that chases what is absolutely universal in the spiritual order with its own constituents and decrees.<sup>1</sup>

---

\*Assistant Professor, Department of English, Dhaka International University, Dhaka, Bangladesh.

**Correspondence to:** Dr. Shah Alam Chowdhury, E-mail: shahjabeen2010@gmail.com

Yeats had a life-long concern also for recognizing and nurturing in Irish culture and art of those spiritual elements that were universal but, in his opinion, most noticeably present in Ireland<sup>1</sup>.

### **Definition**

Spiritualism is the belief that there is hidden meaning in life or that each human being can unite with God. It also means the belief that living people can communicate with people who have died.

### **Spiritualism in Islam and Christianity**

In Islam, Sufism is the doctrine of spiritualism. It searches for a direct mystical knowledge of God and His love. Sufism is a school for the actualization of celestial ethics. It involves an enlightened inner being, not intellectual proof; revelation and witnessing, not logic. Sufism used a figurative method opposing to the literal elucidation which looked for the hidden meaning and symbols in the holy texts. The substance of Sufism is the Truth and the meaning of Sufism is the selfless experiencing. The practice of Sufism is the intention to go towards the truth by means of love and devotion.<sup>2</sup>

Christians have their thoughts little different than Islamic idea of spiritualism. Webster defines Spiritualism as: “The belief that the dead survive as spirits which can communicate with the living, especially with the help of a third party, called a medium.” In Islam this medium is called spiritual guide.

The National Spiritualist Association of Churches defines Spiritualism as: “The science, philosophy and religion of continuous life, based upon the demonstrated fact of communication, by means of medium ship, with those who live in the Spirit World.”<sup>3</sup>

### **Hypothesis**

My main objective is to find out the spiritualism and universality of the thoughts and ideas of W. B. Yeats that are revealed in his poetry. This work will observe the realistic representation of his mystic and religious philosophy of life.

---

## Research Methodology

To complete the research study, stimulation came from the study of the poetry of W. B. Yeats from different critical studies of English literature. The 'Keen Observation Method' was applied successfully for this research work. By using this method, the researcher goes through different literary articles, critical compositions, and websites to find interrelated study materials, in order to be acknowledged in the allied topics. The researcher also collects some poems of the poet and composes the research work in a convincing way after studying those.

## A Short Biography of W. B. Yeats

Yeats was born in Dublin. The juvenile Yeats was very much part of the fin de siècle in London; simultaneously he was active in societies that endeavored an Irish literary revival. Together with Lady Gregory he founded the Irish Theatre, which became the Abbey Theatre, and served as its chief playwright until the movement was joined by John Synge. His plays usually treat Irish legends; they also reflect his fascination with mysticism and spiritualism. *The Countess Cathleen*, *The Land of Heart's Desire*, *Cathleen ni Houlihan*, *The King's Threshold*, and *Deirdre* are among the best known.<sup>4</sup>

After 1910, his dramatic art took a sharp turn toward a highly poetical, static, and esoteric style. Yeats is one of the few writers whose greatest works were written after the award of the Nobel Prize. He got Nobel Prize in 1923. Whereas he received the Prize chiefly for his dramatic works, his significance today rests on his lyric achievement. His poetry, especially the volumes *The Wild Swans at Coole*, *Michael Robartes and the Dancer*, *The Tower*, *The Winding Stair and Other Poems*, and *Last Poems and Plays*, made him one of the outstanding and most influential 20<sup>th</sup> century poets writing in English. His recurrent themes are the contrast of art and life, masks, cyclical theories of life (the symbol of the winding stairs), and the ideal of beauty and ceremony contrasting with the tumult of modern life. William Butler Yeats died on January 28, 1939.

Yeats' gravestone was made with his famous epitaph: "the place that has really influenced my life most is Sligo." Sligo is also home to a statue and memorial building in his honor.<sup>5</sup>

---

### **Spiritualism in W. B. Yeats**

William Butler Yeats is one of the most significant poets in the English language of the twentieth century. He had a life-long interest in mysticism and spiritualism. In 1885, Yeats and several friends formed the Dublin Hermetic Order. Yeats became heavily involved with heretics and theosophical beliefs, and in 1900 became head of the Hermetic Order of the Golden Dawn.

Yeats' father, John Butler Yeats, moved the family to London when Yeats was two years old. The Yeats family moved back and forth between Dublin and London several times during the poet's youth. His poetry was permeated and immersed with images and symbols and he attributed this element to his artistic studies. Yeats returned to London where he met important literary figures such as George Bernard Shaw and Oscar Wilde. The twin elements of Dublin and London played an important role in the progress of Yeats' aesthetic sensibility. Yeats' poetic vision was also heavily indebted to Irish folklore, spirituality, mythology, and the occult. Yeats was intrigued by the spiritual and mystical elements of Irish mythology and his interest in the spiritual domain was something that he pursued in depth.

One of the most significant personal influences in Yeats' life was the feminist poet Maud Gonne. Yeats always referred to Gonne as his muse and unrequited love. Yeats proposed to Gonne's daughter after Gonne turned down his proposal. At the age of 51 Yeats married Georgie Hyde Lee in 1917. Lee was twenty five years junior to Yeats but the wedding was a success. She shared Yeats' interests in mysticism and spiritualism. She introduced Yeats' to the technique of automatic writing and experiments with trances and the spirit world. C. M. Bowra said about Yeats that,

“Yeats does not regard poetry as complete in itself, with its own ritual and meaning. He sees it as part of a larger experience, as a means of communication with the spiritual world which lies behind the visible. For him the poet is almost a medium, and interpreter of the unseen and his poetry is the record of the revelations given to him.”<sup>6</sup>

### **Major Spiritual Elements**

#### **Soul**

---

The rejection of Christian principles in favor of a more supernatural approach to spirituality creates a unique flavor in Yeats' poetry that impacts his discussion of history, politics, and love. Yeats is perhaps the one modern poet who built up a system of thought based on the occult and mystic religion and whose poetry was the direct outcome of it. *The Last Poems* of Yeats are steeped in spiritualism. *A Dialogue of Self and Soul* is in a way a debate between 'Atma' and 'Maya'. Here Soul says,

“Upon the stars that marks the hidden pole;  
Fix every wandering thought upon  
That quarter where all thought is done;  
Who can distinguish darkness from the soul?”

### **Mystic Reincarnation**

Mysticism is being conscious not only of a divine presence in nature but also of the existence of an essential identity of being between man, nature and God. Yeats had a deep fascination with mysticism, and his poetry is infused with a sense of the otherworldly, the spiritual, and the unknown. His interest in the occult began at the School of Art in Dublin. Afterward his study of Theosophy developed through his participation in the Hermetic Order of the Golden Dawn, a mystical secret society. Under the influence of the people of this society Yeats came to believe in re-incarnation. Mysticism figures prominently in Yeats' discussion of the reincarnation of the soul, as well as in his philosophical model of the conical gyres used to explain the journey of the soul, the passage of time, and the guiding hand of fate.<sup>7</sup>

### ***The Second Coming***

One of the aspects of Yeats that intrigued the readers was his ability to wrap numinous and conceptual ideas in concrete words and images such as in *The Second Coming*.

“Turning and turning in the widening gyre  
The falcon cannot hear the falconer  
Things fall apart; the center cannot hold  
Mere anarchy is loosed upon the world”

*The Second Coming* is similar to the holy sonnet in that the speaker can't control the fate of himself or the world. He speaks of a world in chaos where-

---

“The falcon cannot hear the falconer.”

In this metaphor, the falcon is the speaker, or a human, and the falconer is God. The speaker goes on to say that ‘the Second Coming’ is at hand; not the second coming of Christ, but the second coming of the pagan gods, which is represented by the ‘rough beast’, its hour comes at last and then it,

“slouches toward Bethlehem to be born.”

Yeats believed that every 2000 years, the cycle of the world changes. So the speaker in the poem is living during a time when the cycle is changing, which is why there is chaos. Again, this poem puts the fate of the speaker and the world in the hands of the gods. However, unlike the holy sonnet, this poem isn’t about the speaker’s relationship with God, but rather the lack of relationship and the arrival of new gods. The poem isn’t about the relationship with God at all. It is about the chaotic times where it seems like God has left to let the new gods take over.<sup>8</sup>

### **The Sages**

The appeal of the Roman Catholic is to the saints, whose lives on earth are commemorated, and whose present spiritual existence in the other world is represented, by the monuments. Such is the poet's attitude toward the ‘sages’ in *Sailing to Byzantium*. He does not say, “Come from the gold mosaic.” He says:

“O sages standing in God's holy fire  
As in the gold mosaic of a wall,  
Come from the holy fire. . . .”

The sages are to come from the holy fire, not from the gold mosaic, which, like the statues of saints for the Catholic, is merely the visible representation of the sages and the holy fire. If Yeats meant that the art might actually become animate, he would be little more than an idolater, or, even if he meant it only as a metaphor, it would be on about the same intellectual level as a fairy tale for children.

Of course, from a strictly rationalist standpoint, coming from the holy fire would be crude magic, but this symbol for a mystical, spiritual contact with the holy dead has considerable religious sanction and therefore a certain degree at least of intellectual dignity.

### **Gyre**

---

The 'gyre' is a circular or conical shape that appears recurrently in Yeats' poems and was developed in his book *A Vision*. He used the image of interlocking gyres—visually represented as two intersecting conical twists—to represent his idealistic belief that all things could be described in terms of cycles and patterns. The soul or the civilization or the age would move from the smallest point of the spiral to the largest before moving along to the other gyre. This interlocking gyres reveals Yeats' belief in fate and historical determinism as well as his spiritual attitudes toward the development of the soul. With the image of the gyre, Yeats created a shorthand reference in his poetry that stood for his entire philosophy of history and spirituality.

### **Rough Beast**

Yeats uses the figure of a rough beast—an appalling, vicious animal—to personify difficult abstract concepts. The great beast represents evil and darkness. In *The Second Coming*, it emerges from the Spiritus Mundi, or soul of the universe, to function as the primary image of devastation in the poem.

Yeats depicts the commencement of apocalyptic events: “blood-dimmed tide is loosed”

Again he says: “ceremony of innocence is drowned”

The world enters into a new age and the things fall apart as a result of the widening of the gyres. The speaker predicts the arrival of the Second Coming, and this prediction summons a enormous figure of a scary monster pulled from the consciousness of the world. Yeats modifies the well-known image of the sphinx to embody the poem's vision of the coming. By providing the horrifying prospect of commotion and change into a probable appalling monster Yeats makes an abstract and touchy fear. The rough beast slouches toward Bethlehem to be born, where it will evolve into an anti-Christ figure for the dark new age. In this way, Yeats uses distinct, concrete imagery to symbolize complex spiritual ideas about the state of the modern world.<sup>9</sup>

### **Spiritual Masterpiece: *Sailing To Byzantium***

*Sailing to Byzantium* is indeed one of the most well-known lyrics of W.B. Yeats. And perhaps for good reason as the poem shows how someone can gain immortality through artifice, a structure created by man that exists in both the mortal and eternal realm. Though, it is hardly the only poem where Yeats presents this theme, and by explicating artifice from

---



other poems the readers understand the level of density concerned and, thus, can better appreciate the success in 'Sailing'. Most of the critics have alleged Byzantium in several ways; as a representation of the thoughts, the imaginative act, the soul, apparition, and Unity of Being. The poem has also been sighted and construed as the source of supreme beauty and permanent appeal of artifacts. According to Yeats old age is useless if at that time one does not respond to spirituality, or the soul's claps and songs. Here he also depicts the modern spiritual barrenness.

The lyric centers the contrast between the transient and the eternal. The poem transmits the point that human body is mortal and is sure to crumble and expire whereas art or beautifully crafted artifacts are timeless, eternal, unchangeable and of permanent value. The poem is thus the poet's intensifying wish to leave this world of death and sorrow and to escape into a world of immortal beauty perceived imaginatively as a spiritual escape to Byzantium. Byzantium is a world of immortality beyond limits of time and space. It also denotes a place of unity; spiritual or otherwise.

'Byzantium' is indeed an admirable endeavor at bringing together aesthetics, spiritualism, symbolism, and mysticism together on one common platform. The effect is both revealing and enthralling. The epic exploration of the other world brings into perspective, the question of life in death and death in life. The poet metaphorically leaves the world of limitations to steer into a world of permanence and artistic eternity. Tired of life's agonizing existence, the poet seeks recluse and relief in death and beyond.

The flames of the Emperor's pavement are fuelled by deep spiritual realization. Thus, these flames are flames of divine purgatorial fire. The spirits brought to Byzantium by Dolphins through the sea of time are covered with 'mire and blood'; here blood signifies impurity or spurious state. 'Faggot' in the poem signifies martyrdom. This means, the impure spirits must pass through an intensely trying spiritual fire, they must consign themselves to this fire to emerge like a phoenix. This agonizing dance of fire, flames and faggots would eventually turn these spirits into something pure or 'Herculean'.

### **Spiritual Ambivalence**

Yeats is a poet of spiritualism yet spiritual ambivalence finds place in his life for a little moment. Spiritual ambivalence refers to some contradictory attitudes towards the reality and the world. On the one hand, Yeats expresses his desire to flee from the materialized world into the nature and the fairyland; on the other hand, Yeats wants to play an important role in the Irish literature revival and the Irish independence movement. Such ambivalence is caused

by several reasons indeed. The impact of the submissive Romanists, discontent at the repulsive civilization and the introvert and revering personality allow him dispose to flee from the reality to the nature and the fairyland.

### **Conclusion**

Yeats had a life-long interest in mysticism, spiritualism, occultism, astrology and numerology. He read broadly on the subjects all through his life, and was especially influenced by the writings of Emanuel Swedenborg. His spiritual interests are also inspired by his study of Hinduism, under the Theosophist Mohini Chatterjee, and the occult is formed much of the basis of his late poetry.<sup>10</sup>

Yeats offers a wide range, a substantial body of spiritual work, and a mastery of verse: he manifests an exceptionally long and impressive development. A quality of previously determined certainty pervades his poetry, particularly in descriptions of situations of human and divine interaction. Winding stairs, spirals of all kinds, gyres and spinning tops are some of the terms that hold spiritual importance in his later poetry.

Yeats' success in turning his spiritual emotions and likes and dislikes into great poetry was really remarkable. Very few modern poets have succeeded in turning the powers of poetry to such effective spiritual use and yet preserve the necessary impersonality of poetry in which Yeats believed as much as T. S. Eliot did.

### **References**

1. Kirby, R Kenneth. Research Paper 2013: W.B. Yeats, Unity of Culture, and the Spiritual Telos of Ireland. Web. At URL: <http://link.springer.com>
  2. <http://studentacademichelp.blogspot.com>
  3. Stefanidakis, Rev. Simeon; Artricle: *What is Spiritualism?; First Spiritual Temple*, 2001; at URL address: <http://www.fst.org/spirit1.htm>
  4. [www.nobelprize.org](http://www.nobelprize.org)
  5. [www.yeats-sligo.com](http://www.yeats-sligo.com)
  6. Russell, Robert. Online article 2013: William Butler Yeats: Poetic Mysticism and Realism. Web. At URL address: <http://voices.yahoo.com>.
  7. Sen, Dr. S. 'W. B. Yeats 2008: *Selected Poems (An Evaluation of his Poetry)*'. Dhaka: FBC & Unique Publishers,
  8. Nakamoto, Jamie. Online article 2011: *Spirituality Through the Eyes of Donne, Yeats and Marley*. Web. <http://voices.yahoo.com>.
-

9. SparkNotes Editors. 2013. "SparkNote on Yeats' Poetry." SparkNotes.com. SparkNotes LLC. 2002. Web.
10. [www.gradesaver.com](http://www.gradesaver.com)

## Nature of Supernatural treatment in Coleridge's poetry

**Dr. Sazzad Hossain\***

**Abstract:** Samuel Taylor Coleridge is one of the greatest poets of Romantic Movement in English Literature. His thoughts are philosophical but his style is simple and clear. Supernaturalism is his special field. Supernatural elements and events figure prominently in Coleridge's poems. He describes things that are beyond nature. But he describes them in such a way that they appear natural and life-like. In his treatment of supernaturalism he differs from some of his contemporaries Mrs. Radcliff and others who create horror by showing reshaped and horrible paces. Coleridge, on the other hand, creates horror by creating horrible atmosphere.

*Key Words: Romantic Movement, supernaturalism, horrible atmosphere.*

### **Introduction**

It is true that what is best in Coleridge's poetry is very small in amount but that little is of great value. He seems to have more interest in describing supernatural elements. But his greatness lies in the fact that he describes them in such a way that appears to be natural and life-like. What is supernatural? Throughout the ages, phenomena which could not be explained by the known laws of nature have been attributed to supernatural powers and influences. If these happenings were led contrary to the benevolent powers they resulted in suffering and misery and they were ascribed to evil spirits. Literature has continuously been enriched by stories in which the supernatural plays an important part. The desire of hearing about the miraculous is as strong in the civilized man as it was in his primitive ancestors, as it is in the native child. The folklores of all ages and countries abound in tales of magic, fairies, spirits ghosts and demons however be explained by the laws of science and that seem to involve gods or music. The interest in the supernatural was an important aspect of the romantic spirit that appeared in the eighteenth century. The fashionable cult of the strangeness turned inevitably to this alluring world of the unknown and exploited it with a reckless carelessness. To Coleridge the supernatural appealed with a special power. Samuel Taylor Coleridge's poems "The Rime of the Ancient Mariner", 'kubla khan' and "Christabel" are the precious assets of English literature for supernatural elements. The objective of the present article is to discuss the nature of these supernatural elements in "The Rime of The Ancient Mariner" and "Kubla Khan".

### **Supernaturalism in The Rime of the Ancient Mariner**

As a poet of the romantic tradition, Coleridge has put the supernatural in his poem "The Rime of The Ancient Mariner". He put it perhaps to satisfy the taste of ordinary people of his day. We find every detail of a sea voyage, the climate of the sea and the condition of the mariners on board. But at the same time there are incidents and scenes in the poem that cannot be believed with reason. Coleridge has created a willing suspension of disbelief here.

---

\* Associate Professor, Department of English, Dhaka International University, Dhaka, Bangladesh.

**Correspondence to:** Dr. Sazzad Hossain, E-mail: sazzaddiu73@gmail.com

The Ancient Mariner is a tale of a curse which the narrator, the Mariner himself, brings upon himself and his companions by killing an albatross without reason. Coleridge's power of handling the supernatural is like the pure music of his verse. The moral of the poem is one of all-embracing love. This poem is full of moral teachings for human beings. Humphry House expresses his agreement with three great critics, Dr. Tillyard, Dr. Bowra, and Robert Penn Warren, that the poem has a very serious moral and spiritual effect on human life. The moral of the ancient Mariner's story is that one should love all God's creatures.

Coleridge is regarded as the greatest poet of the supernatural in English literature and *The Ancient Mariner* is regarded as a masterpiece of supernatural poetry. The elements of supernaturalism in this poem are controlled by thought and study. It is said that, the very center of Coleridge's art lies in his faculty of evoking the mystery of things, and making it actual, widespread, and obsessing. Even better than Wordsworth, he knows how to handle that species of the supernatural whose essence spirit is entirely psychological. The supernatural element in "The Ancient Mariner" is a hallucination, the outcome of remorse; by the most sober of method."<sup>1</sup> His skill in dealing with the supernatural in this poem is two-fold: first, he has fully achieved his aim of making the supernatural appear to be natural; and, second, he has employed suggestive, psychological, and refined sophisticated methods of producing the feelings of mystery and horror in the poem, not crude and sensational like that of the writers before him, i.e. Horace, Walpole, Mrs. Radcliffe and Monk Lewis. The greatness of *The Ancient Mariner* lies chiefly in the technique by which the supernatural has been made believable and convincing. There are, no doubt, a number of impossible, incredible, and fantastic situation in the poem, such as: the mesmeric or magnetic power in the mariner's gaze, the sudden appearance of the mysterious skeleton ship, the spectre woman and her mate, the coming back to life of the dead crew, the seraph-band making signals to the land, the sudden sinking of the ship, and the polar spirit commenting on or influencing the course of events. But these supernatural phenomena are so skillfully blended with the perfectly believable and natural phenomena that the whole looks real. The sun shining brightly at the outset, the mist and snow, the freezing cold of the polar regions, the floating ice bergs floating in the water, the torrid (very hot) fierceness of stagnant water, the slimy things crawling on the sea, the moon going up the sky, the roaring wind, the rainfall—such are the natural phenomena in the poem. The realistic effect is enhanced by a description of the state of mind of the ancient mariner, that is, how he tried to pray but he could not, how lonely he felt on a wide, wide sea, how he wanted to die but in vain, how he suffered mental and spiritual torture. This psychological study of the mariner adds to the realistic effect because we are made to feel that any man would suffer in the same way under similar circumstances. Again, the details of the ship's voyage have such a fiary-like air that we accept them as a faithful recording of facts. There is, too, the logic of cause and effect in the poem. The punishment and torture have a convincing cause behind them.

The realistic effect achieved by Coleridge in *The Ancient Mariner* is one of his great creations which make the poem not only convincing and exciting but also in some sense a criticism of life.

There are a large number of situations and episodes in *The Ancient Mariner*, which fill us either with a sense of mystery or a feeling of horror or with both. The first situation that strikes terror in the heart of the Mariner (and also the reader) is the appearance of the skeleton-ship. When this skeleton-ship is sighted in the distance, the sailors feel happy to think that they will now get water to quench their burning thirst. But in a few moment they discover the reality of this ship. The description of the ship with its “ribs” and its “gossamere-like sails” fill us with terror. It is a strange mystery that this ship should sail on the sea without wind and without a tide, while the Mariner’s ship stands still “like a painted shop upon a painted ocean”. Obviously, it is a supernatural force, which drives the ship, and the crew also consists of supernatural characters. The feeling of terror is heightened when a reference is made to the crew of this ship. The crew consists of Death and Life-in-Death. But Coleridge creates the sense of horror in this poem not by describing a direct and crude description but by employing suggestive and psychological methods. For instance, he does not describe the physical features of the spectre woman and her death mate or other external phenomena at length, but he simply portrays the effect of those external things on the mariner’s mind.<sup>2</sup> The appearance of Life-in-Death is described in the following three lines: Her lips were red, her looks were free,/ Her locks were yellow as gold:/ Her skin was as white as leprosy. (Lines 190-92) These three lines are followed by these two: The night-mare Life-in-Death was she,/ Who thicks man’s blood with cold. (lines 193-94) Coleridge, after giving us only three lines of description, conveys the horror by saying that the sight of her would have the effect of freezing a man’s blood. In other words, he leaves it to us to imagine for ourselves the horrible appearance of Life-in-Death that personifies the unspeakable torture of a man who cannot die.

Coleridge merely offers a few suggestions to be developed by the reader himself. The effect of the skeleton-ship with Death and Life-in-Death on board again conveyed to us by the following two lines:

“Fear at my heart, as at a cup,  
My life-blood seemed to sip!”

That is, instead of giving us a detailed description of the whole horrible sight, Coleridge refers to the effect of that horrible sight upon the mind of the Mariner and says that fear sipped his life-blood. Another situation that produces horror in the poem is the death of the two hundred sailors who dropped down one by one, and each of them looked at the ancient Mariner with a curse in his eyes:

“One after one, by the star-dogged Moon,  
Too quick for groan or sigh,  
Each turned his face with a ghastly pang,  
And cursed me with his eye.”

The ancient Mariner heard a whiz-like sound every time a soul left its body:

“The souls did from their bodies fly,—  
They fled to bliss or woe!  
And every soul, it passed me by,

Like the whiz of my cross-bow!”

What a horrible experience it must have been for the ancient Mariner and how horrible for the reader too. The agony and spiritual torture of the lonely ancient Mariner on a wide wide sea when he could not pray or die are, perhaps, the most terrifying and horrifying elements in the poem. The following stanzas convey some of the horror of the Mariner’s state:

“I looked upon the rotting sea,  
 And drew my eyes away;  
 I looked upon the rooting deck,  
 And there the dead men lay.  
 I looked to heaven, and tried to pray;  
 But or ever a prayer had gusht,  
 A wicked whisper came, and made  
 My heart as dry as dust.”

What makes the situation still more horrifying is that the curse in dead men’s eyes had never passed away: “The look with which they looked on me Had never passed away.” “Seven days, seven nights, I saw that curse, And yet I could not die.” Here, again, no ugly details are provided. We are to imagine the horror of the situation ourselves. We shudder (tremble) with fear to think of the Mariner who is left alone after seeing “four times fifty living men” dropping down one by one, “with heavy thump, a lifeless lump.” It is at this stage that the Wedding-Guest begins to experience a sensation of fear because he thinks that the Mariner himself must also have dropped down dead and that it is the Mariner’s ghost who is now speaking to him and so he says:

‘I fear thee, ancient Mariner!  
 I fear thy skinny hand!

.....  
 I fear thee and thy glittering eye,  
 And thy skinny hand, so brown.’

Next, the groaning, stirring, and coming back to life of the dead crew must have been a terrifying experience for the ancient mariner till he discovered that the bodies were inspired not by their original souls but by a troop of angelic spirit. We are certainly terrified when we read:

“The dead men gave groan,  
 They groaned, they stirred, they all uprose,  
 Nor spake, nor moved their eyes;”  
 “They raised their limbs like lifeless tools  
 We were a ghastly crew.”

In real life, if a dead man happens to open his eyes (because he has not really died), all the mourners get terribly frightened and run away helter-skelter. In this case two hundred dead men got up on their feet and started working at the oars.

The horror of the situation can well be imagined. Again, towards the close of the poem, the poet wishes to tell us how horrifying the Mariner’s face appeared after he had undergone his strange

adventures. The poet does not describe the features of the face; he simply describes the effect of the face upon the Pilot's mind:

"I moved my lips—the Pilot shrieked  
And fell down in a fit;"

In other words, the Mariner's face was ghastly like the face of a dead man, and it struck so much terror in the Pilot's heart that the Pilot fainted. The Pilot must have thought that the Mariner was not a human being but some horrible spectre. The effect on the Pilot's boy was that he went crazy with fear:

"I took the oars: the Pilot's boy,  
Who now doth crazy go,  
Laughed loud and long, and all the while  
His eyes went to and fro."

As for the Hermit, he too was terrified but, being a holy man, he sought courage from God:

"The holy Hermit raised his eyes,  
And prayed where he did sit."

The Hermit is, indeed, badly shaken and, on stepping forth from the boat, could scarcely stand because of fear:

"The Hermit stepped forth from the boat,  
And scarcely he could stand."

In a nervous state of mind, the Hermit asks the Mariner to tell him immediately what manner of man he is. In short, the horror of the Mariner's face is conveyed to us through the reactions of the Pilot, the Pilot's boy, and the Hermit. Coleridge's treatment of the supernatural is quite different from that of such writers as Horace, Walpole, Mrs. Radcliffe, and Monk Lewis. The difference between Coleridge and the others is the difference between the maker of horror and the maker of horrors. Coleridge creates the atmosphere of mystery and fear by indefiniteness and by subtle suggestion, while the others employ crude description and they pile horrors in order to send a cold shiver down the reader's spine and to curdle the reader's blood.<sup>3</sup> The theme of this poem is crime, punishment and reconciliation. In this poem the Mariner did not act but was only acted upon and he was the recipient rather than the doer. He is the recipient of the odd and of the fate. There is a tragic flaw for the Mariner as the killing of the bird starts his suffering. The suffering endured by the Mariner is due to killing the bird that represents imagination, and by killing the bird the Mariner kills the imagination and the loss of the imagination is a kind of death. The Mariner suffers mentally and spiritually, and he is isolated. Then in his suffering, he sees water snakes and blesses them, which eventually releases his suffering.

The ancient mariner is the story of a real life sea voyage pervaded by a supernatural atmosphere. There is an strangeness in the hypnotic eyes of the mariner, the spectral ship with death and nightmare life in death as its crew dicing on the deck, the winds that sound but never come near, the polar spirits entering the corpses of the mariners and activating them, and the mariners ship sinking mysteriously with a thundering sound coming from under the water. Terror is produced by Coleridge's ability to provide visual descriptions of striking vividness. The story with its



supernatural accounts is obviously incredible, but within this frame work there is the human reality:

“God save thee, ancient mariner  
From the fiends, that plague you thus!”

Here Coleridge vividly presents the supernatural issues by dwelling upon the hideous relations on the face of the mariner. This is the indirect way of treatment of the supernatural, Coleridge was perhaps aware of the fact that such supernatural scenes would not be accepted or believed by his readers. Hence he has dealt with the reactions of the persons that we experience.

‘And some is dreams assured were  
Of the spirit that plagued us so  
Nine fathom deep he had followed us  
From the land of mist and snow.’

Then comes the appearance from nowhere of the skeleton ship with gossamer-like sails, carrying death and life in death engaged in a gambling contest. This ship sails on the sea without wind or tide and it disappears as suddenly as it had appeared. The stanza where this incident is described as horrifying in their effect upon us and sends a cold shiver down our spine. The manner of the death of all the sailors except the ancient mariner is supernatural. There is something supernatural about the way in which the dead body of the albatross automatically falls down from the ancient mariner’s neck into the sea. The moving of the ship upon the sea without a wind is supernatural.

‘A speck, a mist, a shape, I wist!  
And still it neared and neared;  
As if it dodged a water-sprite,  
If plunged and tacked and veered.’

In these lines the ancient mariner describes the gradual approach of the skeleton ship. He and his companions had passed a long and weary time, in thirst and loneliness. One day, looking towards the western sky, where the sun was setting, the ancient mariner saw a strange sight. At first the thing appeared like a den in the moving piece of mist; it was still too indistinct to be clearly distinguished.

Then as it came still nearer, the mariner found it had a definite shape-it was a ship, it was moving so fast that it appeared to be escaping from the pursuit of a water spirit. Besides, its course was very unsteady. The strange behavior of the ship made the ancient mariner think that the ship was trying to escape from a water spirit that was pursuing it to take revenge.

The poet skillfully suggests the supernatural nature of the ship. The ship of the ancient mariner was becalmed for there was no wind and tide, but in the same sea there was another ship which was moving fast and very fast. How could the second ship move thus, without wind or tide, unless there was something supernatural about it? <sup>4</sup>

## Supernaturalism in Kubla Khan

“Kubla Khan” by Samuel Taylor Coleridge is one of the most mysterious and ambiguous pieces of poems ever written. Allegedly written after a laudanum induced dream, the author claims to have been planning a two hundred to three hundred line poem before he got interrupted by a man. This is partly true, as the language seems often in genial Christianity.

Coleridge’s philosophy in life was very romantic and so nearly all of his poems exemplify the romantic idea, especially “Kubla Khan”. This romantic poem uses brilliant imagery and metaphors to contrast the ideals of romantic paganism with often in genial Christianity. The vision of paganism is the first idea introduced in the poem. The supernatural reference to “Alph” or Alpheus as it is historically known.

“The sacred river ran  
Though caverns measureless to man  
Down to a sunless sea”

The river Alph is directly related to the Greek god Alpheus, the river god. According to Greek mythology, a pagan belief, the god Alpheus had fallen in love with Arethusa, the daughter of Nereus and a Hesperide. This again adds to the supernatural quality of the poem.

Suggestiveness is the basic feature of Coleridge’s supernaturalism. It is true that a very vivid and graphic description of the surrounding of the pleasure-dome is given in the poem but the supernatural element is suggestive. Coleridge is a superb artist for intermingling the natural and supernatural so that the probable and the improbable interfuse. Here are lines which for sheer suggestiveness and mystery are perhaps unsurpassed.

“A savage place: as holy and enchanted  
As e’er beneath a waning moon was haunted  
By woman wailing for her demon-lover”

A complete story of love’s tragedy is hidden in these three lines. And then the following two lines:

“And ’mid this tumult Kubla heard from far  
Ancestral voices prophesying war!”

The poet in these lines, describes the visionary landscape of the palace of Kubla Khan. Kubla Khan, the mighty emperor ordered to build a pleasure dome. The poet says that the place is a wild one which may be awe-inspiring. Again this is holy and magic land. The influence of magic seems to be there. This place, says Coleridge, is visited repeatedly by a woman to find out her lover who is a demon. Under the fading light of the waning moon she looks for her lover and wails. These lines are full of dream elements that run through the whole poem. Coleridge’s supernaturalism is at its height as he describes a mysterious and terrible landscape.

In lines, 37-46, Coleridge here presents a visionary scene where a maiden is playing her musical instrument and singing. The poet says in these lines, describes the visionary landscape of the palace of Kubla Khan. The poet says that once he saw in a vision or dream that an Abyssinian

girl was playing on a musical instrument called dulcimer. The maid was also singing a wonderful song that charmed the poet. If he could remember that music he could build a pleasure-dome in the air, with his inspired poetry. The poem here gets a supernatural touch with the maid and her musical instrument. The maid is Abyssinian and her instrument is a dulcimer which is from faraway place and time.

‘For he on honey-dew hath fed,  
And drunk the milk of paradise.’

The poem here gets a supernatural touch with boney dew and milk of paradise. These are the foods of magicians and by taking them he could get the supernatural quality himself.

However Coleridge never forgets that his real purpose was to make the supernatural natural and to bring about the “willing suspension of disbelief which constitutes poetic faith.” Whether Kubla Khan is seen as a poem about poetic creativity or about life, it is a convincing work.

### **Conclusion**

Coleridge made the supernatural as the region and haunt of his genius and shows the way to its most artistic use. There are two ways of treating the supernatural, one external and decorative and the other suggestive and psychological. In the first the supernatural horrors may be multiplied through a number of direct and vivid descriptions, in the second they may be subtly suggested and intensified through the depiction of their effect on the human victim. Coleridge knew how to handle that type of the supernatural whose essence is entirely psychological. He creates an atmosphere of mystery and horror by using supernatural elements. The influence of the supernatural has been brought to bear not only on human nature but on phenomenal nature also. Coleridge makes the natural seem supernatural by attributing to nature something of the special power and proficiency of the supernatural. Coleridge is best known for his haunting ballad, Rime of the Ancient Mariner, the dream like Kubla Khan and the unfinished Christabel. He used supernatural elements vastly in his three best known poems and supernaturalism gives him a new identity.

### **References**

1. Duncan Wu. 1998 A Companion to Romanticism, Blackwell Publishing.
2. McGann, Jerome J. 1985 The Beauty of Inflections. Clarendon Press.
3. D.R. Ewen. 1992 Romantic Parodies. London and Toronto: Associated University Presses.
4. James Engell. 1999 Biographia Literaria. London: Princeton University Press.

# Human Rights in Islam: Some Universal Fundamental Rights for Humanity

**Mahua Gulfam<sup>1</sup>**

**Abstract:** Human rights as codified in international documents are claims every human being have by virtue of being a human. Meaning that every state must ensure, through it's laws, that each individual is guaranteed these claims or rights equally. The concern of violating rights of other people within Islamic law calls into attention how Islamic principles can be applied in a state while guaranteeing human rights as universal principles. This study discusses various approaches proposed by Muslim authors on how human rights can be justified in Islam. Human Rights and Islam is a subject which has been of great interest in many circles. The debate on whether Islam and the definition on Human Rights are compatible has raised many voices and concerns, the debate has mainly focused on the unsuitability of Sharia and it's undermining of minorities. The purpose of this essay is to look at the relationship between Islam and Human Rights. This essay will also illustrate the religious debate of Human Rights in Islam.

**Key words:** Human rights, Islam, moral right, legal right, humanus, chastity, slavery, tyranny, sanctity and security, al-nisa, Zalimun, Fasiq, UDHR, Humanity.

## **Introduction**

Islam had played a very significant role towards the development of International Human Rights Law. Human Rights in Islam mean those rights which are granted by Allah and can neither be stopped or suspended nor abrogated as there is no higher purpose to which they are subservient. They are an integral part of Islamic faith. When we speak of human rights in Islam we really mean that these rights have been granted by Allah; they have not been granted by any king or by any legislative assembly. The rights granted by the kings or the legislative assemblies, can also be withdrawn in the same manner in which they are conferred. The same is the case with the rights accepted and recognized by the dictators. They can confer them when they please and withdraw them when they wish; and they can openly violate them when they like. But since in Islam human rights have been conferred by God, no legislative assembly in the world, or any government on earth has the right or authority to make any amendment or change in the rights conferred by God. No one has the right to abrogate them or withdraw them.

The charter and the proclamations and the resolutions of the United Nations cannot be compared with the rights sanctioned by God; because the former is not applicable to anybody while the latter is applicable to every believer. They are a part and parcel of the Islamic Faith. Every Muslim or administrators who claim themselves to be Muslims will have to concept, recognize and enforce them. If they fail to enforce them, and start denying the rights that have been guaranteed by God or make

---

<sup>1</sup> Lecturer , Faculty of Law, Dhaka International University, Dhaka, Bangladesh.

**Correspondence to : Mahua Gulfam**, E-mail : mahua777gulfam@gmail.com,01743722716

amendments and changes in them, or practically violate them while paying lip-service to them, the verdict of the Holy Quran for such governments is clear and unequivocal.<sup>1</sup>

Those who do not judge by what God has sent down are the dis-Believers (Kafirun). 5:44.

The following verse also proclaims: “They are the wrong-doers (zalimun)” (5:45), While a third verse in the same chapter says: “They are the evil-livers (fasiqun)” (5:47). The rights which have been sanctioned by God are permanent, perpetual and eternal. They are not subject to any alterations or modifications, and there is no scope for any change or abrogation<sup>2</sup>

**Objective:** Objective of this study is to analyze the significant role of Islam forwards the development of International Human Rights Law. To recognize that the concept of Human rights derived from Holly Quran not from the Western Europe. The Human Rights which are codified in Holy Quran in now traceable in modern Human Rights Law.

**Methodology:** This discussion is based on the data and documents collected from text-books, publications, articles, journals, websites and so on. It is a religious and legal research. This essay is descriptive in nature.

**Concept of right:** Right means a claim of some interests adverse by an individual or a group of individuals which has either moral of legal basis and which is essential for his development in the society.

Salmond said, “Rights means an interest recognized and protected by the law, respect or which is a duty, and disregard of which is a wrong”.

Holland said, “Right means a capacity residing in one man of controlling, with the assent and assistance of the state, the actions of others”.<sup>3</sup>

**Kinds of Right:** Rights are primarily divided into two kinds-

**Moral Rights:** Moral Rights are those rights which have their basis on the rule of natural justice and the violation of which results in moral wrong. Rights that are based on general principles of fairness and justice; they are often but not always based on religious beliefs. People sometimes feel they have a moral right even when they do not have a legal right.<sup>4</sup>

**Legal Rights:** Legal Rights, on the other hand, are those rights which are recognized by the positive law of the country and can be claimed on legal basis and the violation of which results in legal wrong. Rights

---

provided for and protected by the law. In other sense, rights that are laid down in law and can be defended and brought before courts of law.<sup>5</sup>

Legal rights are those bestowed onto a person by the law of a particular political and legal system, and therefore relative to specific cultures and governments. Legal rights may be constitutional, statutory, regulatory, contractual, common-law, or conferred by international human rights law. Legal rights are almost always qualified, whether by implication, by the law which created the right itself or by legal rights held by others. A legal right can be enforced in courts of law against another who has infringed the right. The right may be enforced by a court order or injunction prohibiting the other person or persons from infringing a right, by the awarding of money to compensate the holder of the right. If a person's right to liberty is infringed, he or she may bring an action of habeas corpus so that a court can order his or her release.<sup>6</sup>

**Concept of Human Rights:** The word “human” evolved from the Latin word “humanus” which means “any view in which interests of human welfare is central”. Human rights are commonly understood as “inalienable fundamental rights to which a person is inherently entitled simply because she or he is a human being.”

Human Rights which are typically called natural rights or rights of man are those rights that are inherent in human person and without which a man cannot lives as human being. Since human rights came with birth and every person is entitled to them because of the very fact that he or she is a human, they are applicable to all people throughout the world irrespective of their race, color, sex, language, and religion, political or other opinion. Human rights are concerned with dignity and worth of the individual. Human Rights, therefore, have two inherent characteristics—

- (1) Universal inherence and
- (2) Inalienability.

But the term “inalienability” does not apply to all human rights, e.g. rights to property.<sup>7</sup>

Overall, the basic rights and freedoms to which all humans are entitled, often held to include the right to life and liberty, freedom of thought and expression, and equality before the law.

**Modern Concept of Human Rights:** Modern Concept of Human Rights has shape during the long development of democratic society. The concept of human rights first emerged in the thirteenth century in England. After King John violated a number of ancient laws and customs by which England had been

---

governed, his subjects forced him to sign the Magna Carta, or Great Charter in 1215, which enumerates a number of what later, came to be thought of as human rights. This issue of human rights became a tremendous cause in 17th century England. The protection of the people's rights (especially the right to political participation, and freedom of religious belief and observance) against an oppressive government was one of the most important goals of the English Revolution of 1640. It was also the reason for the rebellion against the civil administration - the 'Glorious Revolution' - of 1688 which saw another King on the throne, but also led to the English Bill of Rights.

American Declaration of Independence was declared in 1776 and later in 1791 American Bill of Rights was passed.

In 1789, the people of France overthrew their monarchy and established the first French Republic.

Magna Carta of 1215, the petition of Rights of 1628, the bill of Rights 1688, the Act of Settlement 1710, the American Declaration of Independence 1776, the American Bill of Rights 1791, the French Declaration of Rights of Man and Citizen 1789, were milestone in the road on which the individual acquired protection against capricious acts of kings and despots and the right to lead a free life in a free society. And the modern ideas of Human Rights are to be expressed through passing the Universal Declaration of Human Rights in 1948.<sup>8</sup>

**Magna Carta 1215:** Magna Carta was infact a treaty of peace between the king john of England and the wealthy landowners or barons in arms. The provisions of it were designed to ensure-

- (a) The prohibition of imposing arbitrary taxation by the king without the assent of Great Council and the Prohibition seizure of the property by the Royal officials.
- (b) Freedom of Movements of the merchants within the realm.
- (c) Trial by Jury etc.

**The Bill of Rights:** The Bill of rights which is described as, “An act declaring the Rights and Liberties of the subject and setting the succession of the crown”. It Was the outcome of the seventeenth century struggle of Parliament against the arbitrary rule of the Stuart Monarchs and the Declaration of Human Rights.

The contents of Bill of Rights were as follows:

- (1) Suspending and dispending of laws shall be illegal
  - (2) Erection of royal commission and courts shall be illegal.
  - (3) Keeping or raising standing army in time of peace shall be illegal unless parliament agreed.
  - (4) Election of Parliament shall held frequently
-

(5) Parliament to enjoy full liberty to speech and debate.

It is important to note that the Act of Settlement also regarded as an instrument which helped to develop the concept of Human rights in England.<sup>9</sup>

The Bills of Rights contain the following documents:

1. The Universal Declaration of Human Rights, 1948.
2. International Covenant on Civil and Political Rights, 1966.
3. International Covenant on Economic, Social and Cultural Rights, 1966.
4. Optional Protocol to the International Covenant on Civil and Political Rights, 1966.
5. Optional Protocol to the International Covenant on Economic, Social and Cultural Rights, 1966.

**The Universal Declaration of Human Rights:** The United Nations adopted a Universal Declaration of Human Rights in 1948. This Universal Declaration of Human Rights (UDHR)- the first segment of the international Bill of Human Rights is the basic International pronouncement of the universal inalienable and inviolable rights of all members of the human family. The Declaration is based on the principle of equality and non-discrimination as regards the enjoyment of all the rights and freedoms set forth in it. The Declaration has its own importance and cannot be regarded as having merely a historical significance. This Declaration consists of 30 Articles.<sup>10</sup>

Article 1 provides the philosophy upon which the Declaration is based. Article 2 provides the basic principle

of equality and non-discrimination in case of enjoyment of Human rights and Fundamental rights.

Article is

called the 1<sup>st</sup> Corner stone. Article 22 is called the second corner stone. Article 23-27 ensures economic,

social and cultural rights. Article 28-30 provides the limitation of enforcement of these rights.<sup>11</sup>

**UN and Human Rights:** The Charter of the United Nations is the foundational treaty of the international organization called the United Nations. This organization is established on the 24<sup>th</sup> Oct, 1945. The United Nations Charter sets forth the "inherent dignity" and the "equal and inalienable rights of all members of the human family." Upholding these human rights principles as "the foundation of freedom, justice, and peace in the world" is fundamental to every undertaking of the United Nations.

---



United Nations intergovernmental bodies dealing with human rights. The General Assembly is the main deliberative body of the United Nations. Made up of 185 Member States, it reviews and takes action on human rights matters referred to it by its Third Committee and by the Economic and Social Council.

The Commission on Human Rights is the main policy-making body dealing with human rights issues. Composed of 53 member Governments, it prepares studies, makes recommendations and drafts international human rights conventions and declarations. It also investigates allegations of human rights violations and handles communications relating to them.

The Commission has established a number of subsidiary bodies, including the Sub-Commission on Prevention of Discrimination and protection.<sup>12</sup>

The UN Charter consists of a preamble and a series of articles grouped into chapters.

The preamble consists of two principal parts. The first part containing a general call for the maintenance of peace and international security and respect for human rights. The second part of the preamble is a declaration in a contractual style that the governments of the peoples of the United Nations have agreed to the Charter. Article 1, 55,56,62,68, and 76 also deal with the provisions relating to Human Rights.<sup>13</sup>

**The Western Approach:** The people in the west have the habit of attributing every good thing to them and try to prove that it is because of them that the world got this blessing; otherwise the world was steeped in ignorance and completely unaware of all these benefits. Now let us look at the question of human rights. It is very loudly and vociferously claimed that the world got the concept of basic human rights from the Magna Carta of Britain; though the Magna Carta itself came into existence six hundred years after the advent of Islam. But the truth of the matter is that until the seventeenth century no one even knew that the Magna Carta contained the principles of trial by Jury; Habeas Corpus, and the control of parliament on the right of Taxation. If the people who had drafted the Megna Carta were living today they would have been greatly surprised if they were told that their document also contained all these ideals and principles. They had no such intention, nor were they conscious of all these concepts which are now being attributed to them. As far as my knowledge goes the westerners had no concept of human rights and civic rights before the seventeenth century. Even after the seventeenth century the philosophers and the thinkers on jurisprudence though presented these ideas, the practical proof and demonstration of these concepts can only be found at the end of the eighteenth century in the proclamations and constitutions of America and France. After this there appeared a reference to the basic human rights in the constitutions of different countries. But more often the rights which were given on paper were not actually given to the people in real life. In the middle of the present century, the

---

United Nations, made a Universal Declaration of Human Rights, and passed a resolution against genocide and framed regulations to check it. But as you all know there is not a single resolution or regulation of the United Nations which can be enforced. They are just an expression of a pious hope.<sup>14</sup>

### **Relationship between Human Rights and Islam:**

The genie of the concept of human rights in the contemporary sense is the belief in the sacredness of human personality. This sacredness is supposedly universal and absolute at ideal and conceptual levels, at least and it has some consequences, which means that certain choices should be made for all human beings and certain choices should be rejected for any human being. ‘The Universal Declaration of Human Rights’ (UDHR-1948), ‘International Covenant on Civil and Political Rights’ (ICCPR-1966), and ‘International Covenant on Economic, Social, and Cultural Rights’ (ICESC-1966) -- the three documents constituting ‘The International Bill of Human Rights’-- commonly speak of ‘human dignity’ as something which should be respected in its own right. There is also the ‘Declaration on Elimination of All Forms of Intolerance and of Discrimination Based on Religion or Belief’, which has not become a part of the International Bill so far. Moreover by giving references to Biblical teachings like ‘love on another’ and ‘brother/sister-hood’, there is elaborate relationship between the concept of equality as expounded in the idea of human rights and Islam. Equality cannot be assumed unless we assume that all human beings belong to the same origin. Obviously such teachings are also mentioned in holy scriptures like the *Qur’an*, which lays emphasis on the belief that all human beings were created from Adam and Eve, and in this sense, tied in a natural and permanent ‘brother/sister-hood’ or a family (The *Qur’an*, 49:13). Thus this could become an important point of relationship between human rights and Islam. Islam emphasizes on certain *Haququ’l-’Ibad* (Rights of People) such as rights of the neighbor, fellow traveler, parent, wife, children etc. For example that the *Qur’an* puts great emphasis on the ‘right to justice’. The importance of justice is concerned in the *Qur’an* by mentioning “Be just!”(5:8), which is essentially an instruction.<sup>15</sup>

### **Basic Human Rights:**

The first thing that we find in Islam in this connection is that it lays down some rights for man as a human being. In other words it means that every man whether he belongs to this country or that, whether he is a believer or unbeliever, whether he lives in some forest or is found in some desert, whatever be the case, he has some basic human rights simply because he is a human being, which should be recognized by every Muslim. In fact it will be his duty to fulfill these obligations. These are discussed bellow-

---

**The Right to the safety of Life:** The first and the foremost basic right is the right to live and respect human life. The Holy Quran lays down:

Whosoever kills a human being without (any reason like) man slaughter or corruption on earth, it is as though he had killed all mankind.... (5:32).<sup>16</sup>

These instructions have been repeated in the Holy Quran in another place saying:

Do not kill a soul which Allah has made sacred except through the due process of law... (6:151).<sup>17</sup>

There can be several forms of saving man from death. We regard it as our duty to save every human life, because it is thus that we have been enjoined in the Holy Quran.<sup>18</sup>

**Respect for the Chastity of Women:** The third important thing that we find in the charter of Human Rights granted by Islam is that a woman's chastity has to be respected and protected under all circumstances, whether she belongs to our own nation or to the nation of an enemy, whether we find her in the wild forest or in a conquered city; whether she is our co-religionist or belongs to some other religion or has no religion at all. The words of the Holy Quran in this respect are, "Do not approach (the bounds of) adultery". Heavy punishment has been prescribed for this crime, and the order has not been qualified by any conditions.<sup>19</sup>

**The Right to a Basic Standard of Life:**

Speaking about the economic rights the Holy Quran enjoins upon its followers:

"And in their wealth there is acknowledged right for the needy and destitute" (51:19).

The words of this injunction show that it is a categorical and un-qualified order. Furthermore this injunction was given in Makkah where generally the Muslims have to come in contact with the population of the disbelievers. Therefore the clear meaning of this verse is that any one who asks for help and anyone who is suffering from deprivation has a right in the property and wealth of the Muslims; irrespective of the fact whether he belongs to this nation or to that nation, to this country or to that country, to this race or to that race. If you are in a position to help and a needy person asks you for help or if you come to know that he is in need, then it is your duty to help him. God has established his right over you, which you have to honor as a Muslim.<sup>20</sup>

---

**Individual's Right to Freedom:** As stated earlier, the Qur'an is deeply concerned about liberating human beings from every kind of bondage. Recognizing the human tendency toward dictatorship and despotism, the Qur'an says with clarity and emphasis in Surah 3: Al-Imran: 79. Islam has clearly and categorically forbidden the primitive practice of capturing a free man, to make him a slave or to sell into slavery.<sup>21</sup>

**The Right to Justice:** This is a very important and valuable right which Islam has given to man as a human being. The Holy Quran has laid down, "Do not let your hatred of a people incite you to aggression" (5:2). "And do not let ill-will towards any folk incite you so that you swerve from dealing justly. Be just, that is nearest to heedfulness" (5:8). Stressing this point the Quran again says, "You who believe stand steadfast before God as witness for (truth and) fair play" (4:135). This makes the point clear that Muslims have to be just not only with ordinary human beings but even with their enemies.<sup>22</sup>

**Equality of Human Beings:** Islam not only recognizes absolute equality between men irrespective of any distinction of color, race or nationality, but makes it an important and significant principle, a reality. The Almighty God has laid down in the Holy Quran, "O mankind, we have created you from a male and female". In other words all human beings are brothers to one another. They all are the descendants from one father and one mother. "And we set you up as nations and tribes so that you may be able to recognize each other" (49:13).<sup>23</sup>

**Right to Education:** The seeking of knowledge has been repeatedly encouraged in the Holy Quran by the words that one should "see", "look", "think", "judge", "reflect" etc. The prophet (SM) enjoined upon every Muslim to seek knowledge when he said, "Knowledge is incumbent in every male and every female". According to Qur'anic perspective, knowledge is a prerequisite for the creation of a just world in which authentic peace can prevail. The Qur'an emphasizes the importance of the pursuit of learning even at the time, and in the midst of war.<sup>24</sup>

**Right to Economic Security:** Islam recognizes the right to every person, irrespective of caste, creed, and religion to meet their basic economic needs like food, shelter, cloths, education etc. In respect of employment and earnings equal opportunities are open to all. Everyone is allowed to adopt any profession or service according to will and ability except in religious institutions. He will have full freedom to enjoy his earnings which will not be disposed from him through confiscation or other coercive methods. According to Qur'anic teaching every man and woman has the right to work, whether the work consists of gainful employment or voluntary service. The fruits of labour belong to the one

---

who has worked for them - regardless of whether it is a man or a woman. As Surah 4: An-Nisa': 32 states: "to men is allotted what they earn, and to women what they earn."<sup>25</sup>

**The position of Slavery in Islam:** The Muslims were ordered that in expiation of some of their sins they should set their slaves free. It was said that every limb of the man who manumits a slave will be protected from hell-fire in lieu of the limb of the slave freed by him. The result of this policy was that by the time the period of the rightly-Guided Caliphs was reached, all the old slaves of Arabia were liberated. The Prophet alone liberated as many as 63 slaves. The number of slaves freed by Aishah was 67, "Abbas liberated 70", "Abd Allah ibn 'Umar liberated one thousand and 'Abd al-Rahman purchased thirty thousand and set them free. Similarly other companions of the prophet liberated a large number of slaves, the details of which are given in the Traditions and books of history of that period. Thus the problem of the slaves of Arabia was solved in a short period of thirty or forty years.<sup>26</sup>

#### **Rights of Citizens in an Islamic State:**

We have discussed the human rights in general. Now we would like to take up the question of rights of the citizens in an Islamic state. As these rights are more extensive than the general human rights which have been described earlier, they need separate treatment.

**The Security of Life and Property:** In the address which the Prophet delivered on the occasion of the Farewell Hajj, he said, "Your lives and properties are forbidden to one another till you meet your Lord on the Day of Resurrection". God Almighty has laid down in the Holy Quran, "Anyone who kills a believer deliberately will receive as his reward (a sentence) to live in Hell for ever. God will be angry with him and curse him, and prepare dreadful torment for him" (4:93). The Prophet has also said about the dhimmis (the no-Muslim citizens of the Muslim State), "One who kills a man under covenant (i.e. a dhimmi) will not even smell the fragrance of paradise" (Al-Bukhari and Abu Dawud). Along with security of life, Islam has with equal clarity and definiteness conferred the right of security of ownership of property, as mentioned earlier with reference to the address of the Farewell hajj. On the other hand, the Holy Quran goes so far as to declare that the taking of people's possessions or property is completely prohibited unless they are acquired by lawful means as permitted in the Laws of God. The Law of God categorically declares "Do not devour one another's wealth by false and illegal means" (2:188).<sup>27</sup>

---

**The Protection of Honor:** The second important right is the right of the citizens to the protection of their honor. In the address delivered on the occasion of the Farewell Hajj, to which I have referred earlier, the Prophet did not only prohibit the life and property of the Muslims to one another, but also any encroachment upon their honor, respect and chastity were forbidden to one another. The Holy Quran clearly lays down:

- (a) “You who believe, do not let one (set of) people make fun of another set.
- (b) Don not defame one another
- (c) Do not insult by using nicknames
- (d) And do not backbite or speak ill of one another” (49:11-12)<sup>28</sup>

**The Sanctity and Security of Private Life:** Islam recognizes the right of every citizen of its state that there should be no undue interference or encroachment on the privacy of his life. The Holy Quran has laid down the injunction, “Do not spy on one another” (49:12). “Do not enter any houses except your own homes unless you are sure of their occupants consent” (24:27).<sup>29</sup>

**The Security of personal Freedom:** Islam has also laid down the principle that no citizen can be imprisoned unless his guilt has been proved in an open court. To arrest a man only on the basis of suspicion and to throw him into a prison without proper court proceedings and without providing him a reason- able opportunity to produce his defense is not permissible in Islam. The injunction of the Holy Quran is very clear on this point, “Whenever you judge between people, you should judge with (a sense of) justice” (4:58). And the Prophet has also been asked by God, “I have been ordered to dispense justice between you”. This was the reason why the Caliph Umar Said, “In Islam no one can be imprisoned except in pursuance of justice”.<sup>30</sup>

**The Right to Protect against Tyranny:** Amongst the rights that Islam has conferred on human beings is the right to protest against government’s tyranny. Referring to it the Quran says, “God does not love evil talk in public unless it is by someone who has been injured thereby” (4:148). This means that God strongly disapproves of abusive language injustice or tyranny, God gives him the right to openly protest against the injury that has been done to him. This right is not limited only to individuals. The words of the verse are general.<sup>31</sup>

**Freedom of Expression:** Islam gives the right of freedom of thought and expression to all citizens of the Islamic State on the condition that it should be used for the propagation of virtue and truth and not

---

for spreading evil and wickedness. The Holy Quran has described this quality of the Faithful in the following words, “They enjoin what is proper and forbid what is improper” (9:71). In what is improper and forbid what is proper” (9:67). The main purpose of an Islamic Government has been defined by God in the Quran as follows, “ if we give authority to these men on earth they will keep up prayers, and offer poor due bid what is improper” (22:41). The Prophet has said, “ if anyone of you comes across an evil he should try to stop it with his hand(using force) if he is not in a position to stop it with his hand then he should try to stop it by means of his tongue then he should at least condemn it in his heart. This is the weakest degree of faith” (Muslim).<sup>32</sup>

**Freedom of Association:** Islam has also given people the right to freedom of association and formation of parties or organizations. Addressing the Muslims, the Holy Quran declares, you are the best community which has been brought forth for mankind. You command what is proper and forbid what is improper and you believe in God (3:110).<sup>33</sup>

**Freedom of Conscience and Conviction:** Islam also gives the right to freedom of conscience and conviction to its citizens in an Islamic State. The Holy Quran has laid down the injunction, “there should be no coercion in the matter of faith” (2:256). But if somebody does not accept Islam, Muslims will have to recognize and respect his decision, and no moral, social or political pressure will be put on him to change his mind.<sup>34</sup>

**Protection of Religious Sentiments:** Along with the freedom of conviction and freedom of conscience, Islam has given the right to the individual that his religious sentiments will be given due respect and nothing will be said or done which may encroach upon this right. It has been ordained by God in the Holy Quran, “Do not abuse those they appeal to instead of God” (6:108).<sup>35</sup>

**Protection from Arbitrary Imprisonment:** Islam also recognizes the right of the individual that he will not be arrested or imprisoned for the offences of others. The Holy Quran has laid down this principle clearly, “No bearer of burdens shall be made to bear the burden of another” (6:164). Islam believes in personal responsibility.<sup>36</sup>

**Equality before Law:** Islam gives its citizens the right to absolute and complete equality in the eyes of the law. As far as the Muslims are concerned, there are clear instructions in the Holy Quran and hadith

---

that in their rights and obligations they are all equal, “The believers are brothers (to each other)” (49.10). Prophet said that who accept the oneness of God, Muslim community and brotherhood, “then they have the same rights and obligations as other Muslims have”(Al-Bukhari, Al-Nisa’i). According to the Quran, Pharaoh used to indulge in, “He had divided his people into different classes, And he suppressed one group of them (at the cost of others)<sup>37</sup>

## Conclusion

That the individual is absolute, that his or her reality must be recognized unconditionally and necessarily lies at the basis of human rights. The Lawyers of Western Europe thought that Human Rights are the concept of their time. But this concept of the Lawyers of the Western Europe about Human Rights is not correct. Near about fifteen hundred years ago the concept of Human Rights was codified by Holly Quran and Sunnah. The Human Rights which codified in Quran is now traceable in International Human Rights Law. As the Human Rights which were codified in Islamic law is the creation of God, so it can not be suspended for the time being. No conditions can be imposed upon it and it must not be changed by human being. These Rights and Laws are equally applicable on the whole Humanity without any discrimination on the grounds of race, color, sex, religious etc. So this is a brief sketch of those rights which fifteen hundred years ago Islam gave to man which every believer regards as sacred as law. It refreshes and strengthens our faith in Islam when we realize that even in this modern age which makes such loud claims of progress and enlightenment, the world has not been able to produce just and more equitable laws than those given fifteen hundred years ago.

## References

1. P.Forsthe, David, 2009, Encyclopedia of Human Rights, Oxford University, Newyork, First edition, p.20.
  2. Abu Al-‘A’ la Maududi, Allamah, Human Rights in Islam (Al Tawhid Journal, Vol. IV No.3 Rajab-Rahmadhan, 1407).
  3. Ahamuduzzaman, 2008, International Human Rights Law,Shams Publication, Dhaka, 2<sup>nd</sup> edition,p.01.
  4. [www.1.umn.edu/humanrts/edumat/hreduseries/hereandnow/Part-...](http://www.1.umn.edu/humanrts/edumat/hreduseries/hereandnow/Part-...)
  5. *ibid*
  6. [en.wikipedia.org/wiki/Legal\\_rights](http://en.wikipedia.org/wiki/Legal_rights)
  7. [en.wikipedia.org/wiki/human\\_rights](http://en.wikipedia.org/wiki/human_rights)
  8. <http://www.lincoln.edu/criminaljustice/hr/History.htm>
  9. Ahamuduzzaman, 2008, International Human Rights Law, Shams Publication, Dhaka, 2<sup>nd</sup> edition, p.18.
-



10. Brownlie Ian & Goodwin-Gill Guy S, 2003, Basic Documents on Human Rights, Fourth edition, p.85.
11. Mafizul Islam,A.B.M & Akhteruzzaman, Md. 2007, Elements of Human Rights and Legal Aid,Humanist and Ethical Association of Bangladesh, 3<sup>rd</sup> edition, p.30.
12. en.wikipedia.org/wiki/UN\_and\_human\_rights
13. Brownlie Ian & Goodwin-Gill Guy S, 2003, Basic Documents on Human Rights, Fourth edition, p125.
14. [http://www.lincoln.edu/western\\_approach/hr/History.htm](http://www.lincoln.edu/western_approach/hr/History.htm)
15. An-Naim, Abdullahi (forthcoming) *ISIM Working Paper*, (ed.) Farish A. Noor, Leiden & Boven, Theo Van, 1998, *A Universal Declaration of Human Responsibilities* in Barend van der Heijden and Bahia Tahzib-lie (Eds.) *Reflections on the Universal Declaration of Human Rights*, Martinus Nijhoff Publishers,73-79
16. Surah 5: Al-Ma'idah:32.
17. Abu Al-'A' la Maududi, Allamah, Human Rights in Islam (Al Tawhid Journal, Vol. IV No.3 Rajab-Rahmadhan 1407).
18. ibid
19. ibid
20. Fattani Dr.Zubair, Article on Human Rights in Islam, p.4.
21. Asad, Muhammad, 1980, The Message of the Qur'an (translation), (Gibraltar: Dar Al-Andalus), p.778.
22. Islam, G.A. Parwez, 1986, A Challenge to Religion, (Lahore: Idara-e-Tulu'-e-Islam), p.346.
23. Fazlur Rahman, Alhaz Maolana, Interpretation of Holy Quran.
24. Reference here is to Surah 9: At-Tawbah: 122.
25. The Holy Qur'an, p. 194.
26. D, Littman, 1999, Universal Human Rights and Human Rights in Islam (Published in the journal of midstream, New York.
27. Fattani Dr.Zubair, Article on Human Rights in Islam, Texas, USA,p.6.
28. ibid.
29. Fazlur Rahman, Alhaz Maolana, Interpretation of Holy Quran
30. <http://www.crvp.org/book/Series05/V-5/conclusion.htm>
31. Fattani Dr.Zubair, Article on Human Rights in Islam,Texas,USA,p.7.
32. Ibid.
33. [www.islamicacademy.org](http://www.islamicacademy.org).
34. ibid.
35. Ibid.
36. Fyzee, A.A.A., A Modern Approach to Islam, Lahore: Universal Books, 1978, p.17.

37. Ibid.

# The Laws and Practice regarding Confessional Statements: A Critical Analysis

Sadia Yeasmin\*

**Abstract:** A confessional statement is the cognomen of admitting the commission of an offence or criminal act. The sensitivity of self-atonement devoid of any corporal punishment or mental allurements pertaining to the committed crime or offence is the rudimentary philosophy of confessional statement which can be the edifice of conviction. The very objective of this article is to demonstrate the jurisprudential reality of a confessional statement along with its deviation in Bangladesh followed by multidimensional misuse of this entrenched standard of justice and whether there is any glimpse of egress.

**Key words:** Confession, confessional statement, evidence, admission, voluntary and involuntary admission, coercion, physical and mental torture, judicial confessions, extra judicial confessions, incriminating facts, exculpatory, recording evidence, recording confession, remand, Section(s) – 17, 24, 25, 26, 27, 28, 29 and 30 of Evidence Act 1872.

## Introduction

Confessional statement is the spontaneous and voluntary outcome of one's own realization via inner sanction of conscience that what is he /she committed is an offence or crime. It works as a solace in the mind of a real offender with the hope of divine mercy and lessened penalty via criminal administration of justice of a given country. Confessional statement is recognized as evidence for conviction of the confessor in every legal system of the world. By the efflux of time, the reality of confessional statement has been deviated per cent from its original jurisprudential philosophy as confessional statements have been extracting now -a - days via extra legal maneuver of coercion, torture both physical and mental, corruption, nepotism, political interference, etc. for multifaceted purposes by the law enforcing agencies. In many cases, recording of confessional statements have been turned into an immediate by product of remand<sup>1</sup> which is the epitome of injustice, torture and unconstitutional reality. In consequence, the dream of justice and rule of law have been shattered in Bangladesh as many innocent people have been bound to tell the false confessional statement whereof the truth scowls on the surface of its forced grave.

---

\* Lecturer, Department of Law, Dhaka International University. Dhaka, Bangladesh.  
**Correspondence to :** Sadia Yeasmin, E-mail: [sadialima80@yahoo.com](mailto:sadialima80@yahoo.com)

Any civilized country cannot allow false confessional statement which is obtained by illegal third degree method to be used as evidence by the court to find out the fact. It is high time for all the stakeholders to come forward to prevent all the illegal and unlawful practices pertaining to confessional statement for the sake of irrefutable principle of natural law which is justice must not only be done but also seem to be done.

### **Outline of confession and confessional statement**

Although the term “Confession” has not been expressly defined in any statute, this term finds mentioned in the Code of Criminal Procedure and the Evidence Act<sup>2</sup>. The provisions relating to confessions are incorporated under the heading of ‘admission’. The Act has used the term ‘admission’ to mean confession. Therefore, the definition of admission, as given in Section 17, is applicable to confession. Section 17 defines admission as “a statement oral and documentary which suggests any inference to any fact in issue or relevant fact.”

According to the dictionary meaning confession is “an acknowledgement of offence”. As defined, in a very wider sense, by Stephen in his Digest of the Law of Evidence, confession is an admission made at any time by a person charged with a crime stating or suggesting the inference that he committed a crime. Therefore, confession seems to be a statement which is a direct acknowledgement of guilt and does not include merely inculpatory admission which falls short of being admission of guilt. Furthermore, Lord Atkin observed<sup>3</sup> that no statement containing self-exculpatory matter could amount to confession, if the exculpatory statement was of some fact, which if true, could negate the offence alleged to be confessed. As considered in State Vs. Lalu Miah and another, 39 DLR (AD) 117<sup>4</sup> “A confession must either admit in terms of the offence or at any rate substantially all the facts which constitute the offence”. In the law of criminal evidence, a confession is a statement by a suspect in crime which is adverse to that person. Some secondary authorities, such as Black's Law Dictionary, define a confession in more narrow terms, e.g. as "a statement admitting or acknowledging all facts necessary for conviction of a crime," which would be distinct from a mere admission of certain facts that, if true, would still not, by themselves, satisfy all the elements of the offence.<sup>5</sup>

Confession means admission of the guilt in terms of the offence<sup>6</sup>. Evidence extracted from an accused often proves to be substantive as no evidence can supersede an explicit confession from an accused. The well-known maxim, *habemus optimum-testem, confidante reum*, meaning that a confession against an accused was the best evidence against him applied in

such cases. However, confessions would be of two types. Judicial confessions are substantive evidence while extra-judicial confessions, if found & reliable, are admissible in a court of law. However, by virtue of Sections 25 and 26, all extra-judicial confessions made to police officers or in police custody are not admissible. This is, of course, the normal rule as enunciated in the Indian Evidence Act, 1872. The rationale behind this staple rule is quite simple. The powers of the police are often abused for the purpose of extortion and oppression and confessions obtained by the police through undue influence will be subject to judicial review. In enacting these provisions, the legislature had in view the malpractice of police officers to gain credit by securing convictions and that those malpractices went to the length of positive torture. Therefore, it is a natural rule that confession to police officers or even in the custody of police officers is not admissible in court as the Court cannot rely on the neutrality of the Police, however, in case of such confession material corroboration by evidence of unimpeachable character depending on the veracity of witness to whom it is made might form the base of a conviction. Moreover, no statement is of some fact which if true would negative the offence alleged to be confessed. Moreover, a confession must either admits in terms of an offence or at any rate substantially all the facts which constitute the offence. An admission of gravely incriminating facts, even a conclusively incriminating fact is not of itself a confession, e.g. an admission that the accused is the owner of and was in recent possession of the knife or revolver which caused a death with no explanation of any other man's possession<sup>7</sup>. Exculpatory statements may however in certain circumstances subsequently become evidence of guilt itself. In that way they become confessions and attract sections 24 and 27 of the Evidence Act. But the formality indicated in S. 164 (3) Cr.P.C. 1898 cannot be made to apply when the maker of the statement does not intend to confess, but intends to do just and the opposite<sup>8</sup>. A confession must relate to the particular crime with which the accused is charged, and any admission which is not connected with any of the ingredients of the offence charged would not amount to be a confession<sup>9</sup>. Confession must either admit in terms of the offence or at any rate substantially all the facts which constitute the offence, exculpatory portion of judicial statement to be rejected being contrary to evidence but court connect the accused person on the basis of the inculpatory portion of the statement and the judicial statement of the accused is admissible as confessional statement. A statement is confession, if it be of such a nature that it alone can be the basis of conviction. A statement containing self-exculpatory matter is never a confession<sup>10</sup>. However a statement made under this section which does not amount to confession can be used against the maker as an admission within the purview of sections 18 and 21 of the Evidence Act, 1872. The fact

that an admission is made to a magistrate while he is functioning under S. 164 CrPC, 1898 cannot take it outside the scope of the Evidence Act.

### **Legal regime pertaining to confession in Bangladesh**

Sections 164 and 364 of the Code of Criminal Procedure<sup>11</sup> provide how the confession should be recorded and Sections 24 to 30 of the Evidence Act deal with admissibility and inadmissibility of a confessional statement. In an overabundance of judicial pronouncements<sup>12</sup> the principles governing the recording of confessional statements, its admissibility and use as evidence and the norms of appreciation as to its reliability and forming the basis of conviction have been laid down.

Section 164 of the CrPC, 1898 provides:

- (1) Any Metropolitan Magistrate, any Magistrate of the first class, and any Magistrate of the second class specially empowered in this behalf by the Government may, if he is not a police-officer record any statement or confession made to him in the course of an investigation under this Chapter or at any time afterwards before the commencement of the inquiry or trial.
- (2) Such statements shall be recorded in such of the manners hereinafter prescribed for recording evidence as is, in his opinion best fitted for the circumstances of the case. Such confessions shall be recorded and signed in the manner provided in section 364, and such statements or confessions shall then be forwarded to the Magistrate by whom the case is to be inquired into or tried.
- (3) A Magistrate shall, before recording any such confession, explain to the person making it that he is not bound to make a confession and that if he does so it may be used as evidence against him and no Magistrate shall record any such confession unless, upon questioning the person making it, he has reason to believe that it was made voluntarily; and, when he records any confession, he shall make a memorandum at the foot of such record to the following effect:-

"I have explained to (name) that he is not bound to make a confession and that, if he does so, any confession he may make may be used as evidence against him and I believe that this confession was voluntarily made. It was taken in my presence and

hearing, and was read over to the person making it and admitted by him to be correct, and it contains a full and true account of the statement made by him.

(Signed)A.B.  
Magistrate."

**Explanation**-It is not necessary that the Magistrate receiving and recording a confession or statement should be a Magistrate having jurisdiction in the case.

Section 364 of the CrPC, 1898 says about the manner in which the statement of the accused person shall be recorded. The rules laid down in this section as to the mode of recording statements are, however, applicable like to confessions taken before inquiry or trial under section-164 and to the examination of the accused under section-342.

Section 24 of the Evidence Act 1872 stipulates that a confession is irrelevant in a criminal proceeding if appears to the court that it has been made by inducement, threat or promise Section 25 of the Evidence Act absolutely excludes from evidence against the accused a confession made by him to a police officer. Section 27 of The Act, however, provides an exception to the prohibition imposed by section 25 to the extent that information even by way of confession made in police custody which relates distinctly to the fact discovered is admissible in evidence against the accused. Section 28 of the Evidence Act should be read as an exception to section 24 that no confession made under inducement, threat or promise can be relevant except in the circumstances. Section 29 of Evidence Act covers the field of confessions of extra-judicial confessions made under circumstances similar to those which make judicial confessions inadmissible. Section 30 of the Evidence Act deals with confessions made where more persons than one are being tried jointly for the same offence affecting himself and others, may be taken into consideration not only against the maker but also against the co-accused.

### **Evidential value of confessional statements recorded under section 164 in evidence**

In a criminal case, a confessional statement is considered to be an important piece of evidence<sup>13</sup>. Such a statement may be the sole basis for convicting the maker if it is proved to be voluntary and true, although the statement may be retracted at a subsequent stage<sup>14</sup>. However, the court must also be satisfied that the statement has been recorded in accordance with law as provided in section 164 of the Code<sup>15</sup>. Where, however, the confession was not recorded in the manner prescribed in S. 364, or there was only a gist of the confession in a

narrative form, and where it moreover appeared that the confession was not voluntary, it was held to be inadmissible in evidence<sup>16</sup>. The irregularities in recording a confession can be cured under S. 533 of the CrPC, 1898 only when the court is satisfied that the confession had been made duly, although it was not recorded duly. In other words, the matter is one of substance and not merely that of form<sup>17 & 18</sup>. However, it would not cure a non-compliance if the error inures the accused in his defense on merit<sup>19</sup>.

Previously, the view was that if a confessional statement is partly true, the statement should not be taken in consideration. But the recent view is that a confessional statement, which is partly true and inculpatory and also partly false and exculpatory may be taken into consideration and conviction may also be given on the basis of such statement<sup>20</sup>. A confessional statement should be proved in the court by examining the recording Magistrate as a witness. In the case reported in 42 DLR (AD) 186, the Appellate Division has observed that although section 80 of the Evidence Act provides for making certain presumption in respect of a confession by an accused taken in accordance with law and purporting to be signed by a Magistrate, it was injudicious to rely upon such a confession without calling the Magistrate as a witness. If the Magistrate is not examined as a witness, the accused will be deprived of challenging the validity of the recording by way of cross-examining the Magistrate who recorded the statement.

A confessional statement cannot be the basis for conviction of a co-accused unless there is other corroborative evidence against the co-accused. The provision of section 30 of the Evidence Act, 1872 only empowers the court to take into consideration such a confessional statement against a co-accused. But under this section, such a statement cannot be used against the other accused persons jointly tried with the maker unless there is some other evidence available against those persons<sup>21</sup>. It may happen that a statement made by an accused may not be a confessional statement, but if such statement contains admission of certain facts of the occurrence, such a statement is admissible under sections 18-21 of the Evidence Act, provided it is voluntary<sup>22</sup>. Besides confessional statement of an accused, a statement of a witness may also be recorded under section 164 of the Code. The general view is that such statement is not substantive evidence and can be used under section 145 and 155(3) of the Evidence Act for the purpose of contradiction the maker or for the purpose of corroborating him under section 157 of the Evidence Act. Extra-judicial confession, in an appropriate case, may be taken into consideration. However, it can be the basis of conviction of the maker if such extra-judicial confession is proved by unimpeachable evidence and



found to be true and voluntary<sup>23</sup>. But it has also been held that extra-judicial confession made before a person in authority cannot be relied upon as evidence without independent corroboration<sup>24</sup>. The principle regarding proof of extra-judicial confession is that it must be proved by the persons in whose presence such confession was made. There must be consistency in the statement of such witnesses as to the exact words used by the maker while making extra-judicial confession<sup>25</sup>. Extra-judicial confession of an accused may be taken into consideration like a judicial confession for convicting another co-accused if there are other corroborative evidences<sup>26</sup>.

### **Modus operandi to record confessional statement**

A confession can be made, directly or indirectly: (1) by words or writing, conduct or demeanour of the accused; (2) the accused's words or writing, conduct or demeanour could adopt a statement of another (so as to, in effect, make it the accused's own); or (3) the accused's words or writing, conduct or demeanour could show a consciousness of guilt i.e. not doli incapax. Moreover, any accused including the minor and a deaf or dumb may make a confessional statement but special care is required in recording the statement of such person. Any Metropolitan Magistrate, any Magistrate of the first class and any Magistrate of the second class specially empowered in this behalf by the Government may record the confessional statement (Judicial Confession). The Magistrate need not have jurisdiction to try or handle the relevant case. Extra-Judicial Confession may be recorded by any person capable of recording. Confessional statement should be recorded in court room during court hours unless there are special reasons to the contrary which the prosecution are required to explain<sup>27</sup>.

Confessional statement should not be recorded in the jail and should ordinarily be recorded in the court during court hours in the chamber of the Magistrate. The confessional statement should be recorded in prescribed Form (M-84) but due to lack of Form, plain paper may be used. Also plain paper may be annexed in case of lengthy statement<sup>28</sup>.

The language "may record his statement or confession" as used in section 164 of the Code of Criminal Procedure, 1898 indicates that it is discretion and not obligation to record the confession<sup>29</sup>. Recording of confessional statement is a matter not only of form but also of substance. The recording Magistrate should make his real endeavor for ascertaining that the accused is making the statement voluntarily and should record the confessional statement by strictly following the provisions of sections 164 and 364 Cr. P.C. 1898<sup>30</sup>.

Section 164(2) of the Code provides- “Such statement shall be recorded in such of the manners hereinafter prescribed for recording evidence as is, in his opinion best fitted for the circumstances of the case. Such confessions shall be recorded and signed in the manner provided in section 364 .....” Sub section (3) of the same section provides- "A Magistrate shall, before recording any such confession, explain to the person making it that he is not bound to make a confession and that if he does so it may be used as evidence against him and no Magistrate shall record such confession unless, upon questioning the person making it, he has reason to believe that it was made voluntarily; and, when he records any confession, he shall make a memorandum at the foot of such record”. The requirements of section 364 of the Code of Criminal Procedure, amongst others, are- (1) The whole of the examination of an accused, including every question put to him and every answer given by him, shall be recorded in full, in the language in which he is examined, or, if that is not practicable, in the language of the court or in English. (2) Such record shall be shown or read over to the confessing accused, or, if he does not understand the language in which it is written, shall be interpreted to him in a language which he understands. (3) The accused shall be at liberty to explain or add to his answers. (4) When the whole is made conformable to what he declares is the truth, the record shall be signed by the accused and the Magistrate. (5) In cases in which the examination of the accused is not recorded by the Magistrate himself, he shall be bound, as the examination proceeds, to make a memorandum thereof in the language of the court, or in English, if he is sufficiently acquainted with the latter language; and such memorandum shall be written and signed by the Magistrate or Judge with his own hand, and shall be annexed to the record. If the Magistrate or Judge is unable to make a memorandum as above required, he shall record the reason of such inability. According to the letters and spirit of sections 164 and 364 of the Code of Criminal Procedure, section 24 of the Evidence Act, and according to a number of judicial pronouncements in the leading cases the following, amongst others, may be identified as the duties and obligations of the recording Magistrate: (1) The recording Magistrate should disclose his identity before examining the accused brought before him. He must disclose that he is a Magistrate and not Police Officer<sup>31</sup>. (2) The Magistrate should make real endeavor to place the accused person at ease, dispel all the fear, inducement and hope from accused's mind enabling him to make the confession of his own volition, absolutely free and voluntary according to the best dictates of his own inner conscience. (3) A Magistrate shall, before recording any such confession, explain to the person making it that he is not bound to make a confession and that if he does so, it may be used as evidence against him. (4) The Magistrate should record the questions put to and

answers obtained from the accused person. The following (Phraseology of questions may be different) may be some of the relevant questions :- (i) For how long have you been in the police custody? (ii) Have you understood that you are not bound to make confessional statement? (iii) Was any pressure been brought to bear upon you to make a confession? (iv) Have you understood that if you make the confession it can be used against you as incriminating evidence? (v) Have been told that you will be made an approver? (vi) Why are you making the confession? (vii) Has anybody threatened or induced you or given you any hope or compelled you in any manner for making the confessional statement? (viii) Are you willing to make the confessional statement voluntarily? (ix) If you are willing to make the confession, will you make the true statement? (5) The Magistrate should record the particulars as to when and wherefrom the accused was arrested and wherefrom the accused was placed before him. (6) The Magistrate should ask the accused persons whether he has been mentally or physically tortured while in police custody and record the answer. The Magistrate should make a note on whether or not any mark of physical torture is found on any part of the body of the accused. (7) After making examination as above the accused should be given a reasonable time (at least 3 hours) for reflection to ponder over the matter and during that time the accused should be placed under care of a person who is under control of the Magistrate<sup>32</sup>. At that place no police should be allowed to stay. (8) After the time given for reflection is over, the Magistrate should again ask the accused whether he is willing to make the confession voluntarily and if the answer is yes, the accused should be warned again that his confessional statement may be used against him as incriminating evidence. (9) Inside the room or within sight no police officer should be allowed to remain present and all the police officers should be turned out from that room<sup>33</sup>. (10) No oath should be administered to the accused before recording the confessional statement. (k) Confession should be recorded in the words of the accused, but it is not always correct to say that confession not recorded exactly in the words of the accused is inadmissible<sup>34</sup>. (11) The recorded statement should be read out and explained to the confessing accused. (12) When the accused confirms that the confessional statement has been recorded correctly, it shall be signed by the accused and by the Magistrate. (13) The Magistrate must make a memorandum at the foot of the recorded statement to the following effect-“I have explained to (name) that he is not bound to make a confession and that if he does so, any confession he may make may be used as evidence against him and I believe that this confession was voluntarily made. It was taken in my presence and hearing, and was read over to the person making it and admitted by him to be correct, and it contains a full and true account of the statement made by him”<sup>35</sup>. Making of

the above memorandum is mandatory; its non-compliance affects voluntary character of the confession<sup>36</sup>. (14) Again it is unavoidable duty of the Magistrate that he shall certify under his own hand that the examination was taken in his presence and hearing and that the record contains a full and true account of the statement made by the accused<sup>37</sup>. The Form (M-84) used for recording the confessional statement by the Magistrate itself is a small guiding booklet. The left margin of the form contains certain instructions. The Form states, inter alia: “Magistrates should clearly understand the great importance of giving their closest attention to the procedure to be followed, from first to last, in the recording of confessions. This procedure should be followed without haste, with care and deliberation, it being understood that this duty is not a distasteful and minor, appendage or addition to their normal functions, but one which is of consequence to the confessing accused, his co-accused and court responsible for the administration of criminal justice. A confession which is recorded perfunctorily and hastily is a source of embarrassment to the trial court, the prosecution and the defense.” Along with the above guidelines all other guidelines given in the prescribed Form should be carefully gone through by the recording Magistrate and thereafter the following duties are to be performed: (a) The Magistrate should fill in all the blanks in the Form; (b) He should put his signature at all the places shown in the Form; (c) Under paragraph 3 of the Form the name of the Peon and the place where the accused is kept to wait should be specifically mentioned; (d) The name, address and particulars of the accused as required under Column 7 of the Form must be specifically written; (e) Where and at what time the accused is forwarded should be mentioned under Column 10 of the Form; (f) As required under Column 9 of the Form, if during recording of the statement it appears to the Magistrate that the statement made or about to be made is not voluntary, forthwith the Magistrate shall stop recording of confession stating reasons thereof; and (g) Under Column 8 of the Form the Magistrate should give reasoning, in brief, why he has believed that the statement made before him is voluntary; (h) The Magistrate should specifically note in the Form whether there is any mark of physical torture on any part of the body of the accused. Also the allegation of the accused of torture in any kind either mental or physical or mental, if any, must be noted in the Form.<sup>38</sup>

### **Derogation of laws pertaining to recording of confessional statement**

Burden of proof of admitting a confession is borne by the Prosecution. Improper and irregular recording of the confessional statement is frequently raised in the criminal administration of justice in Bangladesh. If the confession is not recorded in this manner, the record is

defective<sup>39</sup>. The magistrates generally put a series of questions which simply puzzle the confessing accused. When the accused is not given any time for reflection, no question was put to him to ascertain whether he was prepared to make the statement of his own free will, it cannot be said that the Magistrate has made any genuine effort to find out the real character of the confession. If the Magistrate does not fill up the important paragraphs of the Form, the manner of recoding the confession is not acceptable. Recording of the confession in such manner casts seriously doubt as to the voluntary character of the confessional<sup>40</sup>. It is a serious irregularity in recording of confession if by the question put by the Magistrate to the accused, the later was subjected to a kind to Cross examination in the hands of Magistrate<sup>41</sup>. It is commonly and generally alleged by the confessing accused persons and their lawyers that the confession has been extracted by police torture and the law upholding magistrates are not aware enough that in the maximum incidents the accused are humiliated via multidimensional way to confess the offence though the confessor is innocent. Also in many of the retraction petitions and during examination under section 342, of the CrPC, 1898 the allegation of mental and physical torture is raised. There is no guideline, nor is there any practice to separately dispose of the retraction petition upon any inquiry into the allegation of torture for compelling an accused to make the confessional statement. The Constitution of the People's Republic of Bangladesh, the Supreme Law of the land, provides "no person accused of any offence shall be compelled to be witness against himself"<sup>42</sup>. If, in fact, confessions are obtained by compelling the accused in any manner, it is clearly violation of the constitutional right guaranteed to the accused. Many times the recording magistrate just perform his /her routine duty as a mechanical way. Many made confessors have been seen which simply frown at the expectation of justice in Bangladesh<sup>43</sup>. When the accused is not given any time for reflection, no question was put to him to ascertain whether he was prepared to make the statement of his own free will, it cannot be said that the Magistrate has made any genuine effort to find out the real character of the confession. Recording of the confession in such manner casts seriously doubt as to the voluntary character of the confessional statement<sup>44</sup>. The Form M-84 where the confessional statement is recorded is itself a conflicted one with difficult legal jargons in English and very often germinated confusion among magistrates to understand. Lack of proper training to the concerned is also considered as substantial problem for improper and illegal training of confessional training in Bangladesh.

## **Recommendations**

The sole object and the dominant purpose behind the legal regime of confession is to ensure that the confessions of the accused recorded by the concerned magistrate are free and voluntary and are not induced by any threat or promises or under any undue influence<sup>45</sup>. Any forms of hastiness and indifference during the recording of confession statement by the magistrates should be discarded. When recording the confession of an accused the first and the foremost duty of the magistrate is to ask the accused as to the custody from which he is produced and the treatment he has been receiving in such custody in order to ensure that there is no scope for doubt of any sort of extraneous influence proceeding from a source interested in the prosecution still lurking in the accused mind. In the event magistrate fails to do so, the confession recorded by him has been held not to be voluntary<sup>46</sup>. The recording Magistrate must be careful in ascertaining whether the accused placed before him for making confession statement was compelled by torture or by any other manner to make a statement against himself<sup>47</sup>. On the other hand, the trial court as well as the appellate court should make a careful scrutiny of the confession statement, the entries in the Form for recording such statements, comments of the Recording Magistrate and his evidence given in the court. Since the confession statements alone can form the basis of conviction, the Magistrate should not act mechanically in recording the confession statements; it is the solemn duty of a Magistrate to strictly follow the provisions of sections 164 and 364 of the Code of Criminal Procedure for avoiding the possibilities of causing injustice. There may be cases where only for non-compliance of those provisions a confession statement may be left out of consideration by the trial court and appellate court though confession statement was made voluntarily. The confessing person should not be impeded to leave to narrate his story as a whole without any unnecessary interference and allowed to give all the details that he remembers and wishes to describe<sup>48</sup>. The core philosophy is that it must be spontaneous narrative<sup>49</sup> should be ensured at any cost. It is important that the procedure and manner followed by the recording Magistrate must be reflected in the prescribed Form so that the trial court/ appellate court can see whether the recording Magistrate has made real endeavor for ascertaining voluntary nature of the confession. The recording Magistrate must keep in view that for his omission to follow the procedure and guidance, for his slightest negligence and carelessness, an innocent person may be convicted upon a confession shown to be voluntary but not in fact voluntary and, on the other hand, a real culprit may be acquitted though he has made a true confession. It is not

enough for the recording Magistrate that he himself be satisfied that the confession is true and voluntary; he should also reflect everything as required by law for scrutiny of the court which is the ultimate forum to arrive at the decision as to whether the confessional statement is true and voluntary. A magistrate should not before recording a confession, look into police report to see what the accused had stated to the police<sup>50</sup>. The magistrate should not hand over the accused to the investigation officer who was in attendance outside his room and record his confession after he had been with the police officer for a few minutes. There must be an in-depth and meticulous observance of all necessary formalities and precautions provided in S. 164(3) with minute particularity so as to ensure that the confession is absolutely free from slightest inducement or extraneous influence. Magistrate must put question with a view to finding out the real object of confession<sup>51</sup>. The magistrate must not put any question to the accused tending to incriminate him<sup>52</sup>. The magistrate should not hold out any inducement. The Form M-84 where the confessional statement is recorded should be simplified in Bengali language. The concerned magistrates and investigating police should be properly trained up in consonance with right based approach, human rights, rule of law, justice and good governance.

### **Conclusion**

Confessional statement is the peak matrix of a successful criminal administration of justice of any legal system of the world whereof the real culprit depose before the magistrate inculcating him/her hails from self-repentance or modern right based investigation maneuver of investigation to find out the fact as it could be the decisive evidence of the court. It is a matter of great regrets that confessional statements have been extracted via third degree method of illegality for multifaceted illegal considerations dooming the notion of human rights, justice, rule of law, right based approach and constitutional rights; culminated in, higher rate of acquittal in criminal cases in Bangladesh and justice cries in silence. The legal regime pertaining to confessional statement should be strictly followed in terms of letters and spirit without any kind of derogation to uphold the norm "Justice not only be done, it seems to be manifestly done". GO, NGO and other civil society members should take a keen view on the whole dimension of confessional statement and its multifarious misuse to quench the thirst of justice as the single aspiration of our independence. Herein raising awareness among the mass people demands higher degree of priority as vertical and horizontal ignorance triumphs over justice in Bangladesh.

---

## References

1. Sections 167 and 344 of the CrPC,1898.
2. The evidence Act, 1872.
3. AIR 1939 PC 47(52).
4. State Vs. Lalu Miah and another, 39 DLR (AD) 117 (per M.H. Rahman J).
5. [http://en.wikipedia.org/wiki/Confession\\_\(law\)](http://en.wikipedia.org/wiki/Confession_(law)) searched at 10pm on 18/11/2013.
6. 25 DLR 41).
7. (PLD 1971 Pesh 71).
8. (52 Cr.L.J. 561).
9. (AIR 1945 Bom).
10. (5 DLR 41).
11. The Code of Criminal Procedure, 1898.
12. 26 BCR 97. 16 MLR (AD) 35.
13. 8 BLT (AD) 23. 6 BCR (AD) 212.
14. 29 DLR (SC) 271, 59 DLR 17, 396, 6 MLR 205, 51 DLR 244, 53 DLR 268, 49 DLR 573, 55 DLR 137. 14 MLR 258, 7 ADC 427, 6 ADC 886.
15. 41 DLR 62, 19 BLD 74.
16. 36 Cr.L.J. 447.
17. (51 Cr.L.J. 126 Lah PLD 1950 Lah 68).
18. (PLD 1950 Bal 1).
19. (Abdul Hakim v State, 1990 DLD 430).
20. 44 DLR (AD)51 para 16, 3 MLR 57, 6 MLR 205. [For detailed discussion on the evidentiary value of confessional statement see 39 DLR (AD) 117.
21. 25 BCR (AD) 239, 44 DLR (AD) 10 45 DLR (AD) 175, 55 DLR 382, 7 BLC 362, 3 BLC (AD) 53.
22. 25 BCR (AD) 239 para 20. 15 BLT (AD) 251 (para 20).
23. 9 BLC 39, 51 DLR 43, 55 DLR 116. 18 BLT (AD) 3 BLT (AD) 3 (para 291), 16 MLR (AD) 35.
24. 55 DLR 325.
25. 4 BLC 582, 9 BLC 163, 16 MLR (AD) 35.
26. 3 BLD (AD) 329.
27. (48 Cr. L.J. 794 at 791).
28. (5 BLD 9. 37 DLR 66).
29. 36Cr.L.J45.
30. 46 DLR77.
31. AIR1954Tra.Co 456DB).
32. 48DLR1988..
33. (AIR 1954 SC 462).
34. Nausher Ali Sarder and others Vs. State, 39 DLR(AD) 194-paragraph-9.
35. Section 164(3), of the Cr.P.C, 1898.
38. 7CWN220.
37. Section 364(2), Cr.P.C.1898.
38. PLD1964Kar3WW.
39. (26 Cr.L.J. 1209)
40. Statement: Md. Azad Shaikh Vs. State, 8 BLD(HCD) 50
41. PLD 1950 Lah 252 (DB), AIR 1957 MYS 50 (DB).



- 
42. The Constitution of the People's Republic of Bangladesh, the supreme Law of the land Article 35(4).
  43. Jeroge Mia was an artificial confessor in the 21<sup>st</sup> Grenade Attack Case.
  44. [Md. Azad Shaikh Vs. State, 8 BLD(HCD) 50].
  45. (1993 Lah: 354: P. Cr. L.J. 1978 SC 21. DLR 1978 SC).
  46. (1986 Cr. L.J. 439 Ori).
  47. AIR1952Raj97 (83), 1972PakCrlg8 (DB), AIR1956SC217.
  48. (33 Cr.L.J 414).
  49. 1972 Pak Cr.L.J. 775 DB.
  50. (13 CWN 861).
  51. (8 BLD (1998) 190).
  52. (2 Weir 136).

# Validated RP-HPLC Method for Estimation of Halobetasol propionate in Topical Pharmaceutical Preparation

Moynul Hasan<sup>1</sup>, Md. Mahfuzur Rahman<sup>2</sup>, Abdullah Al Masud<sup>3\*</sup>

**Abstract:** The present study was undertaken to develop a validated reversed phase high performance liquid chromatographic (RP-HPLC) method for quantitative determination of Halobetasol propionate in pharmaceutical topical (cream) preparation. The method was based on reversed phase liquid chromatography using a Grace Smart C<sub>18</sub> column (250 × 4.6 mm; 5μ) integrated with PDA (Photo Diode Array) detector where the detection was carried out at 240 nm. The mobile phase consisting of acetonitrile and phosphate buffer (pH adjusted to 5.5) at a ratio of 70:30 (v/v). The injection volume was 20 μL and flow rate was 1.0 mL/min. The linear dynamic response was found 2.5 μg/mL to 20 μg/mL and coefficient of correlation was found to be 0.999. The %RSD value was below 2.0 for intraday and interday precision indicated that the method was highly precise. The LOD and LOQ were found to be 0.05 μg/ml and 0.105 μg/ml respectively for Halobetasol propionate which revealed that the method was highly sensitive. The percentage recovery value was higher than 100 %, indicating the accuracy of the method and absence of interference of the excipients present in the formulation. The proposed method was simple, economic, accurate, precise and reproducible and hence can be applied for routine analysis of Halobetasol propionate in pharmaceutical topical formulation.

**Key words:** Halobetasol propionate, RP-HPLC, Validation.

## Introduction

Halobetasol propionate cream contains halobetasol propionate, a synthetic corticosteroid for topical dermatological use. Halobetasol is a super-potent TCS with additional fluorine at the 6α position when compared with clobetasol (Fig.1&2). The additional fluorine in the 6α position further increases its topical anti-inflammatory and anti-proliferative activities.<sup>1,2,3</sup> Like other topical corticosteroids, halobetasol propionate has anti-inflammatory, antipruritic and vasoconstrictive actions. The mechanism of the anti-inflammatory activity of the topical corticosteroids, in general, is unclear. However, corticosteroids are thought to act by the induction of phospholipase A<sub>2</sub> inhibitory proteins, collectively called lipocortins. It is postulated that these proteins control the biosynthesis of potent mediators of inflammation such as prostaglandins and leukotrienes by inhibiting the release of their common precursor arachidonic acid.

---

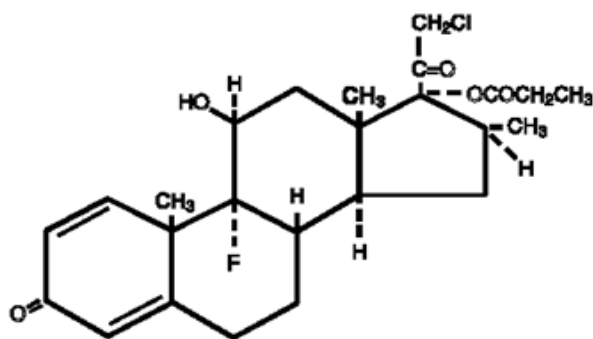
<sup>1</sup>Assistant Professor, Department of Pharmacy, Dhaka International University, Dhaka, **Bangladesh.**

<sup>2</sup>Department of Pharmaceutical Technology, University of Dhaka, Dhaka, Bangladesh.

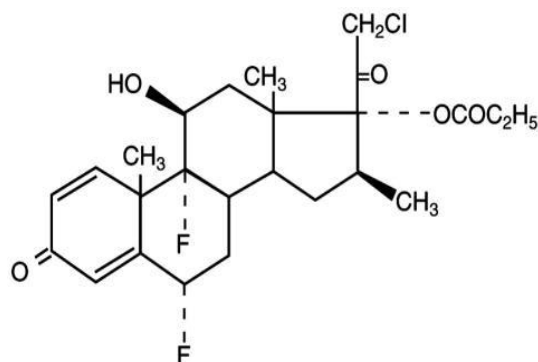
<sup>3</sup>Lecturer, Department of Pharmacy, Jagannath University, Dhaka, Bangladesh

\***Correspondence to:** Abdullah Al Masud, E-mail: masud\_pr14@yahoo.com

Arachidonic acid is released from membrane phospholipids by phospholipase A<sub>2</sub>.<sup>4</sup>



**Fig. 1: Structure of Clobetasol propionate**



**Fig. 2: Structure of Halobetasol propionate**

Chemically Halobetasol propionate is 21-chloro-6 $\alpha$ ,9-difluoro-11 $\beta$ ,17-dihydroxy-16 $\beta$ -methylpregna-1,4-diene-3,20-dione-17-propionate (Fig. 2) with molecular formula C<sub>25</sub>H<sub>31</sub>ClF<sub>2</sub>O<sub>5</sub> (M.W. 485). It is a white crystalline powder insoluble in water. Each gram of Halobetasol propionate cream contains 0.5 mg/g of halobetasol propionate.<sup>4</sup>

A Spectrophotometric method has been reported for determination of clobetasol propionate, halobetasol propionate, quinagolide hydrochloride, through charge transfer complexation.<sup>5</sup> A literature survey revealed that very few HPLC methods have been reported for the determination of Halobetasol propionate in bulk and pharmaceutical preparations but the methods were not validated.<sup>6,7,8</sup> So in this present investigation an attempt has been made to develop a validated HPLC method for the estimation of Halobetasol propionate in bulk drug and in pharmaceutical topical preparation.

## Materials and Methods

**Chemicals and reagents:** Halobetasol propionate was obtained as a gift sample from ACI Pharmaceuticals Ltd. Acetonitrile, methanol and water used were HPLC grade and phosphate buffer used were analytical grade. The commercially available Halobetasol propionate cream claimed to contain 0.05% of active ingredients were procured from local market of Bangladesh.

**Apparatus and chromatographic condition:** The chromatographic separation was performed on a using a Grace Smart C<sub>18</sub> column (250 × 4.6 mm; 5 $\mu$ ) integrated with PDA (Photo Diode Array) detector where the detection was carried out at 240 nm. The mobile phase consisting of acetonitrile and phosphate buffer (pH adjusted to 5.5) at a ratio of 70:30 (v/v). The injection volume was 20  $\mu$ L and flow rate was 1.0 mL/min. Water and methanol was used as diluents. The column and the HPLC system were kept in 40°C.

**Preparation of stock solution:** Stock solution of Halobetasol propionate was prepared by dissolving 25 mg of Halobetasol propionate in a 50 mL volumetric flask containing 30 mL of methanol as diluent and the solution was sonicated for 5 min and then made up to the mark with same diluent to get a concentration of 0.5 mg/mL. Subsequent dilutions of this solution were made with the diluent to get concentrations of 2.5 µg/ml to 20 µg/ml and the chromatogram was recorded by maintaining the chromatographic condition.

**Preparation of sample solution:** 1 gm of cream sample (Equivalent to 0.5 mg of Halobetasol propionate) was accurately weighed and transferred into a 50 ml volumetric flask containing 30 mL of diluent and the solution was heated on a water bath and then sonicated for 5 min. Then the solution was allowed to cool at room temperature and then made up to the mark with the diluent to get a concentration of 0.02 mg/mL. Then it was first filtered through whatman filter paper and then with 0.2µ disk filter and diluted suitably using diluent to obtain a solution of 5 µg/mL. The chromatogram of sample solution was recorded under the same chromatographic conditions as mentioned above.

### **Method Validation**

All of the analytical validation parameters for the proposed method were determined according to International Conference on Harmonization (ICH) guidelines (ICH guidelines Geneva, July 2000).<sup>9</sup>

**Linearity:** The linearity of this method was determined at five concentration levels ranging from 2.5- 20 µg/mL (Table 1). Then 20 µl from each solution was injected using the auto-sampler and the analyses were monitored at 240 nm and repeated three times. The average peak areas were plotted against respective concentration. The linearity of the proposed method was evaluated by using calibration curves to calculate coefficient of correlation and intercept values.

**Precision:** The precision is a measure of the ability of the method to generate reproducible results. The precision of the assay was determined by repeatability (intraday) and intermediate precision (inter-day) and reported as %RSD. For this, 5 µg/mL of the solution was measured three times in a day and the same was repeated in next three days.

**Recovery studies (Accuracy):** Recovery studies were performed to judge the accuracy of the method. The studies were carried out by adding a known quantity of pure drug to the pre-analyzed formulation and the proposed method was followed. From the amount of drug found, the percent recovery was calculated. Recovery study was carried out at three levels 80%, 100% and 120% for the formulation concentration of 5µg/mL.

**System suitability test:** The system suitability tests were carried out on freshly prepared standard stock solution of Halobetasol propionate to evaluate the suitability of the system and the parameters that were studied presented in Table 1. To optimize the chromatographic conditions, various combinations of acetonitrile and buffer were tested and the ratio of 70:30 v/v afforded peak with good shape and resolution.

**Sensitivity:** Limit of detection (LOD) and limit of quantification (LOQ) were calculated by the using the equation given in ICH guidelines based on Signal to Noise ratio, this may be expressed as LOD:  $S/N \geq 2:1$  or 3:1 and LOQ:  $S/N \geq 10:1$ .

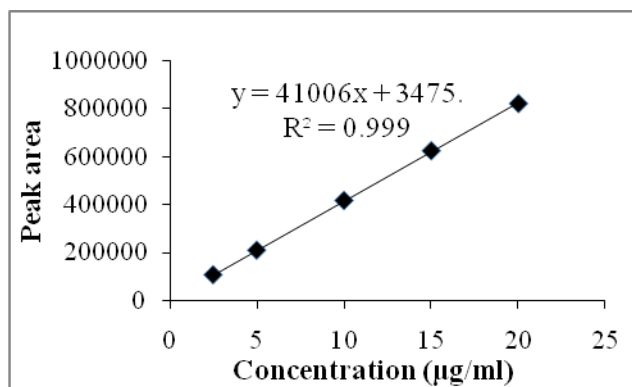
## Result & Discussion

Recently, HPLC is the most convenient and accurate technique for analysis bulk and finished pharmaceutical products. A RP-HPLC method has been developed and validated as per ICH guidelines for determination of Halobetasol propionate in semisolid preparation using mobile phase consisting of acetonitrile and phosphate buffer (pH adjusted to 5.5) at a ratio of 70:30 (v/v) over Grace Smart C<sub>18</sub> column (250 × 4.6 mm; 5 $\mu$ ) integrated with PDA (Photo Diode Array) detector at 240 nm.

**Table 1: Validation Parameters**

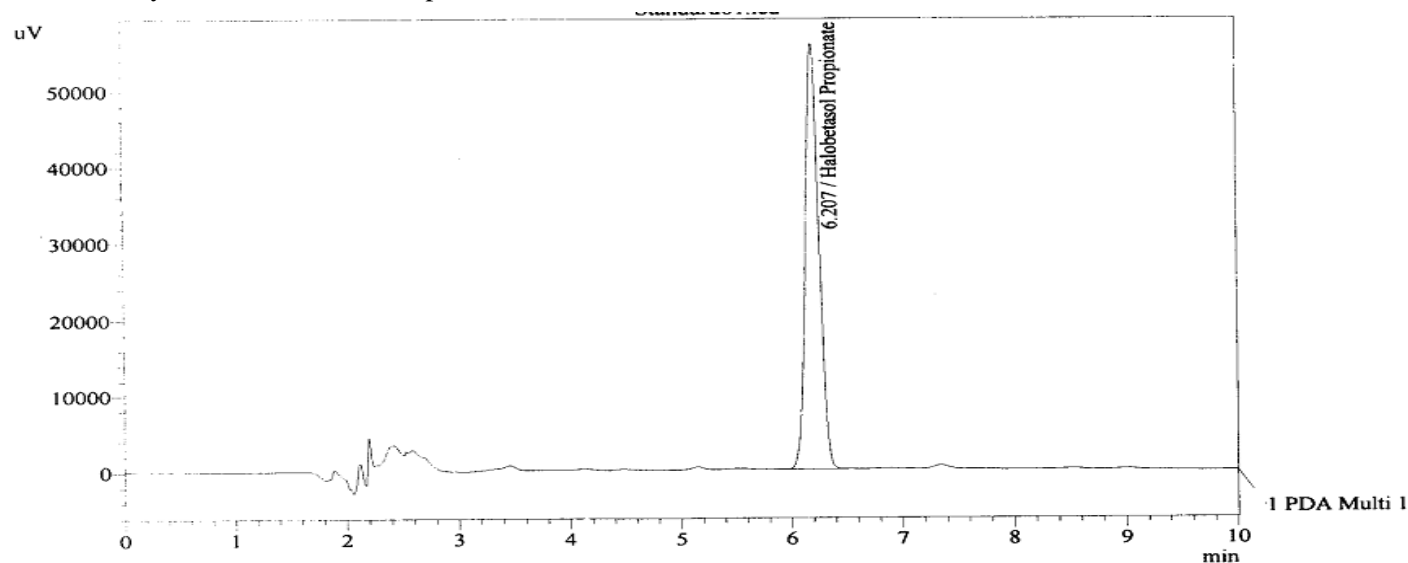
Parameteres	Results		
Linearity range ( $\mu\text{g/ml}$ )	2.5 to 20		
Standard Regression equation	$Y=41006x+3475$		
Correlation coefficient	0.999		
LOD ( $\mu\text{g/mL}$ )	0.035		
LOQ ( $\mu\text{g/mL}$ )	0.105		
Precision	Concentration	Intraday (%RSD)	Interday (%RSD)
	5 ( $\mu\text{g/ml}$ )	0.92	0.65
<b>System suitability parameters</b>			
Retention time (min) $\pm$ S.D.	6.207 $\pm$ 0.025		
No. of theoretical plates	11009		
Asymmetric factor	1.026		

The linear dynamic response was found 2.5  $\mu\text{g/mL}$  to 20  $\mu\text{g/mL}$  and coefficient of correlation was found to be 0.999. The precision (measurements of intraday and interday) results showed (Table 1) good reproducibility with percent relative standard deviation (% RSD) was below 2.0%.. The LOD and LOQ were found to be 0.05  $\mu\text{g/ml}$  and 0.105  $\mu\text{g/ml}$  (Table 1) respectively for Halobetasol propionate which revealed that the method was highly sensitive.



**Fig. 3: Calibration curve of Halobetasol propionate**

From the typical chromatogram of Halobetasol propionate as shown in Fig. 4, it was found that the average retention time, ( $\pm$ ) standard deviation for Halobetasol propionate was found to be  $6.207 \pm 0.025$  minutes for five replicate injections. The asymmetry factor was found to be 1.026 (Table 1), which indicated asymmetric nature of the peak.



**Fig. 4: Typical chromatogram of Halobetasol propionate**

The number of theoretical plates was found to be 11009 (Table 1), which suggested an efficient performance of the column. The absence of additional peaks in the chromatogram indicated non-interference by the common excipients used in the semisolid formulation.

**Table 2: Recovery study**

Formulation (µg/mL)	Level of Addition (%)	of Addition of pure drug (µg/mL)	% Recovery of pure drug	Recovery (%) ± S.D.
5 (µg/mL)	80	4	101.56	101.62±0.58
	100	5	102.24	
	120	6	101.08	

The percentage recovery value was higher than 100% (Table 2), indicating the accuracy of the method and absence of interference of the excipients present in the formulation.

**Table 3: Determination of active ingredients**

Sample	Label claimed/gm	Amount found/gm	% Amount found*
Halobetasol Propionate	0.05 gm	0.0506±0.67	101.2

(\* Average of three determinations)

The proposed method was also applied for the assay of Halobetasol propionate in semisolid preparation (in triplicate) and the results are shown in Table 3. Hence, this method can be used for the routine determination of Halobetasol propionate in pure sample and in semisolid (Cream) preparations.

## References

1. Mensing H, Korsukewitz G, Yawalkar S. 1991. A double-blind, multicenter comparison between 0.05% halobetasol propionate ointment and 0.05% betamethesone dipropionate ointment in chronic plaque psoriasis. *J. Am. Acad. Dermatol*, **25**, pp. 1149-1152.
2. Mohandas, A., Rai, R., Srinivas, C.R. 2009. Halobetasol versus clobetasol: A study of potency. *Ind. J. Dermatol. Venereol. Leprol.* **75(2)**, pp. 186-187.
3. Goldberg B, Hartdegen R, Presbury D, Smith EH, Yawalkar S. 1991. A double-blind, multicenter comparison of 0.05% halobetasol propionate ointment and 0.05% clobetasol propionate ointment in patients with chronic, localized plaque psoriasis. *J. Am. Acad. Dermatol*, **25**, pp. 1145-8.

4. [www.Medicine Online.com](http://www.Medicine Online.com)
5. Mostafa AA, Lories I, Bebawy LI, Heba H, Refaat HH. 2002. Spectrophotometric determination of clobetasol propionate, halobetasol propionate, quinagolide hydrochloride, through charge transfer complexation. *J. Pharm. Biomed. Anal.*, **27(6)**, pp.889-899.
6. Chakole CM, Shende MA, Khadatkar SN. 2009. Formulation and evaluation of novel combined halobetasol propionate and fusidic acid ointment. *Int. J. Chem.Tech. Research*, **1(1)**, pp.103-116.
7. Ankam R, Mukkanti K, Durgaprasad S, Naidu P V L. 2010. Simultaneous Determination of Halobetasol Propionate and Fusidic Acid Related Substances by Reversed Phase High Performance Liquid Chromatographic Method, *Asian Journal of Chemistry*, **22(5)**, pp.3376-3380.
8. Cravotto G, Giovenzana GB, Masciocchi N, Palmisano G, Volante P. 2007. A degradation product of halobetasol propionate: characterization and structure, *Steroids* , **72(11-12)**, pp. 787-791.
9. ICH guidelines. July 2000. Analytical method validation (Q3). Geneva.



## Evaluation of antinociceptive activity of ethanolic extract and other fractions of *Desmodium pulchellum* (Fabaceae) bark in mice.

Zebunnesa Ahmed<sup>1</sup>, Mohammad Saydur Rahman<sup>2\*</sup>, G. M. Alamin<sup>3</sup>

**Abstract:** In this study the antinociceptive activity of ethanolic extract and other fractions of *Desmodium pulchellum* (Fabaceae) were evaluated by acetic acid induced writhing method. The crude ethanolic fraction, pt. ether soluble fraction and carbon tetrachloride soluble fraction at a dose of 400 mg/kg had shown significant antinociceptive activity. They produce an inhibition of writhing of 67.23%, 58.20% and 61.48% where as standard diclofenac sodium inhibits 73.77% of writhing. All other fractions tested also had mild antinociceptive activity. The results of the study suggested significant dose dependent antinociceptive activity of extracts as compared to control group.

**Keywords:** *Desmodium pulchellum*, Antinociceptive activity, Acetic acid induced writhing, Diclofenac.

### Introduction

Herbs are staging a comeback and herbal ‘renaissance’ is happening all over the globe. The herbal products today symbolize safety in contrast to the synthetics that are regarded as unsafe to human and environment. Many of the herbs and spices used by humans as seasonal food yield useful medicinal compounds<sup>1-2</sup>. The use of, and search for, drugs and dietary supplements derived from plants have accelerated in recent years. Pharmacologists, microbiologists, botanists, and natural-products chemists are combing the earth for phytochemicals and which could be used for developing treatment of various diseases. In fact, according to the World Health Organization, approximately 25% of modern drugs used in the United States have been derived from plants<sup>3</sup>. Extensive varieties of bioactive compounds are being isolated from medicinal plants day by day. Hence medicinal plants serve as an important source of raw materials for drug discovery. Among the 120 active compounds currently isolated from the higher plants and widely used in modern medicine today, 80 percent show a positive correlation between their modern therapeutic use and the traditional use of the plants from which they are derived<sup>4</sup>. So many investigations are now being conducted on the plant source for searching new molecule for different disease conditions where the existing actives commencing various adverse effects. During this procedure, the analysis of the efficacy of plant-based drugs used in the traditional medicine has been paid great attention<sup>5</sup>.

<sup>1</sup> Zebunnesa Ahmed, Assistant Professor, Department of Pharmacy, Dhaka International University, Dhaka, Bangladesh.

<sup>2</sup> Mohammad Saydur Rhaman, Lecturer, Department of Pharmacy, Jagannath University, Dhaka, Bangladesh.

<sup>3</sup> G.M. Alamin, Assistant Professor, Department of Botany, Jagannath University, Dhaka, Bangladesh.

**Correspondence to:** Mohammad Saydur Rahman, E-mail: Saydur\_pr@yahoo.com

*Desmodium pulchellum* Benth. (Fabaceae), a stoutish shrub, an indigenous plant in Thailand and it is abundant in Khon Kaen. The plant is distributed in the tropical areas and widely distributed in Bangladesh, India, Srilanka, and Southern China<sup>6</sup>. Traditionally the plant is used in cold and fever, malaria. Leaves are applied to ulcers.<sup>7</sup> Decoction of bark is used for diarrhea, eye afflictions, malaria, swelling and rheumatism.<sup>8</sup> The plant is used by chineses for traditional remedy of schistosomiasis. Some chemical constituents like, alkaloids, bufotenin, Indole-3 alkaline bases, tryptamine derivatives have been isolated from the whole plant<sup>9-10</sup>. Pharmacological investigations of the plant have not been thoroughly explored. The plant possesses antihelmintic, behavioral and anti- hepatofibrotic activities<sup>11</sup>. In the traditional practice the barks of this plant has been used to control swelling and rheumatism. The antinociceptive activity of *D. pulchellum* barks is speculative and has not yet been documented. The present study has been undertaken to study the antinociceptive activity of ethanolic extract and other fractions of *D. pulchellum* bark in mice.

## **Materials and methods**

### ***Plant material and extraction***

The plant *Desmodium pulchellum* belonging to the Fabaceae family was investigated for the study.

### **Collection and preparation of the plant material**

Plant sample of *Desmodium pulchellum* (Accession No. : DUSH 4686) was collected from Rangamati on 10 September, 2011. Bark of *Desmodium pulchellum* was washed properly, cut into small pieces and then air dried for several days. The pieces were then oven dried for 24 hours at considerably low temperature to effect grinding. The pieces were then ground into coarse powder in the Phytochemical Research Laboratory, Faculty of Pharmacy, University of Dhaka using high capacity grinding machine.

### **Extraction of the plant material**

About 600 gm of the powdered material was taken in a clean, round bottomed flask (5 liters) and soaked in 2.5 liter of methanol. The container with its content was sealed by foil and kept for a period of 15 days accompanying occasional shaking and stirring. The whole mixtures were then

filtered through a fresh cotton plug and finally with a Whatman No.1 filter paper. The volume of the filtrate was then reduced using a Büchi Rotavapor at low temperature and pressure. The weight of the crude extract was 19 gm.

### **Solvent-solvent partitioning**

Solvent-solvent partitioning was done using the protocol designed by Kupchan and modified by Van Wagenen<sup>12</sup>. The crude extract (5 gm) was dissolved in 10% aqueous ethanol. It was then extracted with petroleum ether (PEF), carbon tetrachloride (CTF). All fractions were evaporated to dryness and were used for the study.

### **Experimental animals**

Swiss albino mice (25-30 g) of either sex, aged 4-5 weeks were obtained from the animal house of Jahangirnagar University. They were housed in standard polypropylene cages and kept under controlled room temperature ( $24 \pm 2^\circ\text{C}$ ; relative humidity 60-70%) in a 12 hour light-dark cycle in the animal house of Institution of Nutrition and Food Science, University of Dhaka and fed ICDDR,B formulated rodent food and water ad libitum. As these animals are very sensitive to environmental changes, they were kept before the test for 3-4 days in the environment suitable for the experiment.

### **Drugs and reagents**

Ethanol, carbontetrachloride, petroleum ether, acetic acid, Twin 80 (Sigma chemicals, USA), diclofenac, (Incepta Pharmaceuticals Ltd.), normal saline (Opsonin Pharmaceutical Ltd.) were collected from the mentioned sources. All the chemicals and solvents were of analytical grade.

### **Antinociceptive test**

The antinociceptive activity of the crude ethanolic extract and other fractions were evaluated using the acetic acid-induced writhing test<sup>13-14</sup>. In the writhing test, thirty male experimental animals were randomly selected and divided into five groups denoted as group-I, group-II, group-III(A-B), group-IV(A-B), group-V(A-B), consisting of 5 mice in each group. Each group received a particular treatment. Prior to the treatment, each animal were weighed properly and

the doses of the test samples and control materials were adjusted accordingly. All animals were identified individually of a group during the treatment.

In order to administer the crude ethanolic extract and other fractions at doses of 400 mg/kg & 200 mg/kg body wt of mice, 100 mg and 50 mg of the extracts were measured respectively and triturated in unidirectional way by adding of small amount of Tween-80 (a suspending agent). After proper mixing of extract and suspending agent, normal saline was slowly added. The final volume of the suspension was made up to 3.0 ml. To stabilize the suspension, it was stirred well by vortex mixture. For the preparation of diclofenac at the dose of 50 mg/kg body weight, 25 mg of diclofenac was taken and a suspension of 3.0 ml was made. All the drugs were administered orally. Acetic acid was administered intraperitoneally.

At zero hour test samples, control (1% Tween-80 solution in saline) and diclofenac sodium were administered orally by means of a long needle with a ball-shaped end. After 40 minutes acetic acid (1%) was administered intra-peritoneally to each of the animals of all the groups. Forty minutes interval between the oral administration of test materials and intra-peritoneal administration of acetic acid was given to assure proper absorption of the administered samples. Five minutes after the administration of acetic acid, number of squirms or writhing were counted for each mouse for ten minutes. Each mouse of all groups were observed individually for counting the number of writhing they made in 10 minutes commencing just 5 minutes after the intra-peritoneal administration of acetic acid solution. Full writhing was not always accomplished by the animal, because sometimes the animals started to give writhing but they did not complete it. This incomplete writhing was considered as half-writhing. Accordingly two half writhing were taken as one full writhing.

Table 1: Test materials used in the evaluation of antinociceptive activity of ethanolic crude extract and its different fractions of *Desmodium pulchellum*.

Code no.	Test Samples	Group	Identification	Dose (mg/kg)	R/A
NC	1% Tween-80 in normal saline	I	Negative Control Group	0.1ml/10 g of body wt	Oral
PC	Diclofenac sodium	II	Standard Group (Positive control)	50	Oral
ECE <sub>200</sub>	Ethanolic (crude) extract	III(A)	Test Sample	200	Oral
ECE <sub>400</sub>	Ethanolic (crude) extract	III(B)	Test Sample	400	Oral
PEF <sub>200</sub>	Petroleum ether fraction	IV (A)	Test Sample	200	Oral
PEF <sub>400</sub>	Petroleum ether fraction	IV(B)	Test Sample	400	Oral
CTF <sub>200</sub>	Carbontetrachloride fraction	V (A)	Test Sample	200	Oral
CTF <sub>400</sub>	Carbontetrachloride fraction	V(B)	Test Sample	400	Oral

**Statistical analysis:** The data were statistically analyzed using one-way ANOVA for individual comparison of group with control. All values are expressed as mean  $\pm$  SEM.  $p < 0.05$  was considered as significant.

## Results

### Acetic acid induced writhing method

Ethanolic crude extract and its different fractions of bark of *Desmodium pulchellum* decreased the number of acetic acid induced abnormal constrictions (writhings) in mice, when compared to control ( $p < 0.01$ ) as mentioned in table 2. Statistical evaluation of the data confirmed that the crude ethanolic extract, pt. ether soluble fraction & carbontetrachloride soluble fraction at a dose of 400 mg/kg had shown significant antinociceptive activity. They produced an inhibition of 67.23%, 58.20% and 61.48% respectively. All other fractions tested also had mild antinociceptive activity. Observation are given in Table 2.

Table 2: Screening of antinociceptive activity by counting the number of writhing after Intraperitoneal administration of 1% acetic acid

Animal Group	Writhing Count					Number of Writhing (Mean $\pm$ SEM)	writhing (%)	Inhibition (%)
	M-1	M-2	M-3	M-4	M-5			
NC	25	21	24	27	25	24.40 $\pm$ 0.98	100	-
PC	6	6	7	5	8	6.40 $\pm$ 0.51	26.23	73.77
ECE <sub>200</sub>	11	15	12	13	14	13 $\pm$ 0.71	53.28	46.72
ECE <sub>400</sub>	9	7	9	8	7	8 $\pm$ 0.45	32.77	67.23**
PEF <sub>200</sub>	16	17	15	18	16	16.40 $\pm$ 0.51	67.21	32.79
PEF <sub>400</sub>	12	9	11	10	9	10.20 $\pm$ 0.58	41.80	58.20**
CTF <sub>200</sub>	12	13	14	16	12	13.40 $\pm$ 0.75	54.91	45.09
CTF <sub>400</sub>	9	11	10	9	8	9.40 $\pm$ 0.51	38.52	61.48**

Values expressed as Mean $\pm$  SEM (n=5). \*\*p<0.01 significant compared to control. NC=negative control, PC=positive control, ECE=ethanolic crude extract, PEF=petrollium ether fraction, CTF=carbontetrachloride fraction,

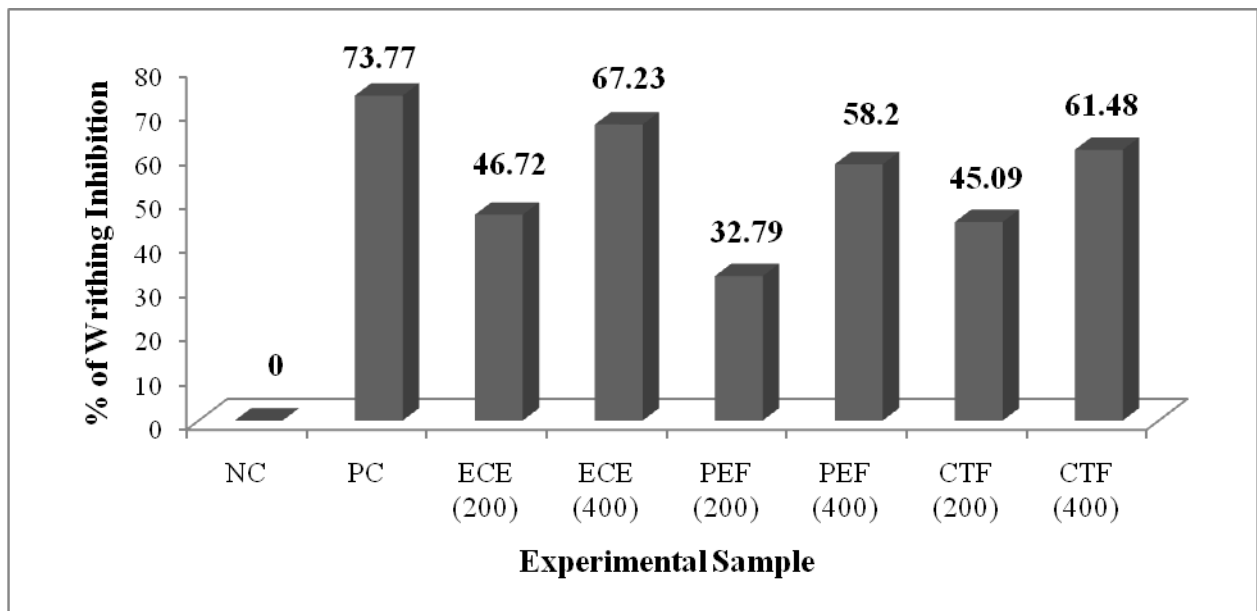


Fig 1: Comparison of % of inhibition of writhing by ethanolic crude extract and other fractions of *Desmodium pulchellum*.

## Discussion:

Acetic acid-induced writhing method represents pain sensation by triggering localized inflammatory response. It induces analgesia by liberation of endogenous substances, which in turn excite the pain nerve endings<sup>15</sup>. Increased levels of PGE2 and PGF2 $\alpha$  in the peritoneal fluid have been reported to be responsible for pain sensation caused by intraperitoneal administration of acetic acid<sup>16</sup>. NSAID such as diclofenac used in this study are known to inhibit cyclooxygenase enzymes I and II which are implicated in the production of inflammation mediating agent prostaglandin from arachidonic acid<sup>17-19</sup>. The ethanolic extract of *Desmodium pulchellum* barks showed statistically significant inhibition on acetic acid-induced writhing in mice. Therefore the possible mechanism behind the antinociceptive effect of ethanolic extract of *Desmodium pulchellum* bark and other fractions may be the inhibition of synthesis or action of prostaglandin.

The anti-inflammatory, antinociceptive and antipyretic activities of many plants have been attributed to their saponin<sup>20</sup>, terpenoids, flavonoids and steroids contents<sup>21</sup>. Moreover, the flavonoids, triterpenoids are known to inhibit prostaglandin synthesis. Based on the results of the present studies, it can be concluded that the ethanolic crude extract & other fractions of the bark of *Desmodium pulchellum* have the favourable antinociceptive activity which is involved in possible inhibition of the synthesis of prostaglandins. The crude ethanolic extract and other fractions of *Desmodium pulchellum* barks might contain phytochemicals like alkaloids, glycosides, steroids, flavonoids, tannin and phenolic compounds which possess antinociceptive activity. However, further detail studies are essential to find out the underlying mechanisms and also to isolate the active compounds responsible for these pharmacological properties.

## References

1. Lai, P.K. and Roy, J. 2004. Antimicrobial and chemopreventive properties of herbs and spices. Current Medicinal Chemistry. Sharjah: Bentham Science Publishers. pp. 1451-1460.
2. Tapsell, L.C., Hemphill, I. and Cobiac, L. 2006. Health benefits of herbs and spices: the present, the future. *Medical Journal of Australia*. 185, pp. 4-24.
3. Barnes, J. and Ernst E. 1998. Traditional herbalists' prescriptions for common clinical conditions: A survey of members of the UK National Institute of Medical Herbalists. *Phytotherapy research*. 12, pp. 369.
4. Fabricant, D.S. and Farnsworth, N.R. 2001. The value of plants used in traditional medicine for drug discovery : *Environ Health Prospect*. Pp. 69-75.

5. Kumara, N.K.V.M.R. 2001. Identification of strategies to improve research on medicinal plants used in Sri Lanka. In: WHO Symposium. University of Ruhuna, Halle, Sri Lanka.
6. Gani, A. 2003. Chemical Constituents and Uses, Medicinal plants of Bangladesh. Asiatic Society of Bangladesh.
7. Rahman, M. K. , Barua, S. , Islam, M. F., Islam, M. R., Sayeed, M. A., Parvin, M. S., Islam, M. E., P. 2013. Studies on the anti-diarrheal properties of leaf extract of *Desmodium pulchellum*. *Asian Pac J Trop Biomed* 2013; 3(8): 639-643.
8. Traditional Uses Of Plants By The Tribal Communities Of Salugu Panchayati Of Paderu Mandalam, Visakhapatnam, District, Andhra Pradesh, India. / S.B.Padal, P. Chandrasekhar & Y. Vijakumar / *International Journal of Computational Engineering, Research*, Vol, 03, Issue 5
9. Ghosal, S. and Mukherjee, 1966. B. Indole-3-alkylamine bases of *Desmodium pulchellum*. *J Org Chem*. 31, pp. 2284-2288.
10. Hjort, S., Sharp, T. and Hacksell, U. 1989. Partial postsynaptic 5-HT<sub>1A</sub> agonist properties of the novel stereoselective 8-OH-DPAT analogue (+) cis-8-hydroxy-1-methyl-2-(di-n-propylamino) tetralin, (+) ALK-3. *Eur J Pharmacol*. 170, pp. 269-274.
11. Chitcharoenthum, M. Theramongkol, P. 1990. Preliminary study: Effects of *Desmodium pulchellum*. *Srinagrind Medical Journal*. 5, pp. 321.
12. Van Wagenen, B.C., Larsen, R., Cardellina, J.H., Ran, D., Lidert, Z.C. and Swithenbank, C. 1993. Ulosantoin, A potent insecticide from sponge *Ulosaruetzleri*. *J org. of chem*. 58, pp. 335-337.
13. Turner, R.A. 1971. *Screening Methods in Pharmacology*, Academic Press: New York. Pp. 100-113.
14. Koster, R., Anderson, M. and De Beer, E.J. 1959. Acetic acid for actinociceptive screening. *Proceedings of the Society for Experimental Biology and Medicine*. 18, pp. 412-415.
15. Taesotikul, T., Panthong, A., Kanjanapothi, D., Verpoorte, R. and Scheffer, J.J.C. 2003. Anti-inflammatory, antipyretic and antinociceptive activities of *Tabernaemontana pandacaqui* Poir. *J. Ethnopharmacol*. 84, pp. 31-35.
16. Derardt, R., Jougney, S., Delevalcee, F. and Falhout, M. 1980. Release of prostaglandins E and F in an algogenic reaction and its inhibition. *Eur. J. Pharmacol*. 51, pp. 17-24.
17. Dhara, A.K., Suba, V., Sen, T., Pal, S. and Chaudhuri, A.K.N. 2000. Preliminary studies on the anti-inflammatory and antinociceptive activity of the methanol fraction of the root extract of *Tragia involucrate* Linn. *J Ethnopharmacol*. 72, pp. 265-268.
18. Wu, K.K. 2003. Aspirin and other cyclooxygenase inhibitors: new therapeutic insights. *Seminar Vascular Med*. 3, pp. 107-112.
19. Parmar, N.S. and Ghosh, M.M.N. 1978. Current trends in flavonoid research. *Indian J Pharm*. 12, pp. 213-228.
20. Oweyele, V.B., Oloriegbe, Y.Y., Balogun, E.A. and Soladoye, A.O. 2005. Antinociceptive and anti-inflammatory properties of *Nelsonia canescens* leaf extract. *J Ethnopharmacol*. 99, pp. 153-156.



21. Adeolu, A.A., Margaret, O.S., Viola, M., Busani, M., Patrick, J.M. and Anthony, J.A. 2008. Anti-inflammatory and antinociceptive activities of the aqueous extract of *Cussonia paniculata* stem bark. *Rec Nat Prod.* 2, pp. 46-53.

# Exposure to Mass Media, National Health Message and HIV/AIDS Campaign in Bangladesh: Challenges and Prospects

Masum Billah<sup>1</sup>

**Abstract :** This paper is about to identify the relationship between socio-economic determinants of People Living with HIV/AIDS (PLHIV) and their exposure to different sources of media in the context of having opportunities and accessibilities to HIV/AIDS campaign program in Bangladesh. The study reveals that around 90 percent of the PLHIV gave consent about watching television and expressed their positive attitudes toward HIV related national messages. About 58 percent of the respondents receive HIV/AIDS related messages and information from satellite channels because it covers the highest percentage of watching television in Bangladesh. The analysis of the study clearly shows that electronic media dominates over print media in question of disseminating health information among PLHIV in the second decades of twenty first century.

**Key Words:** Mass media, HIV/AIDS, Campaign, Satellite channel, Risk group, Message

## Introduction

Mass media is carrying out a dominating role in continuing and shaping the image of tackling challenge of HIV/AIDS awareness building and prevention program across the world. Since media is a very powerful and high-tech mechanism of sharing knowledge and disseminating information about risk practices, very often directed by the finance of global funding and the ideology of local power elite in present society, it might have covered reliable news and authentic reports about this fatal silence. According to national surveys conducted in the United States, 72% of Americans identify television, radio and newspapers as their primary source of information about HIV/AIDS, more than doctors, friends and family<sup>1</sup>. Similar statistics have also been reported in the United Kingdom and elsewhere in the world. In a survey carried out in India more than 70% of respondents said they had received their information about HIV/AIDS from television (UNAIDS, 2004). Being a global catastrophe and menace of modern risk society, all the knowledge based issues and preventive measures about HIV/AIDS are vehemently intertwined with the social, economic and political agenda of the development sector of the country. Bangladesh is geographically more vulnerable to HIV and AIDS epidemic,

---

1. Masum Billah, Lecturer, Department of Sociology, Dhaka International University, Dhaka, Bangladesh.

**Correspondence to:** Masum Billah, Email: [billahmasum87@yahoo.com](mailto:billahmasum87@yahoo.com)

it is still regarded as a low prevalence (of less than 1%) country and it has many epidemiological and social factors that could produce devastating epidemic risk factors such as high prevalence of HIV in the neighboring countries, less awareness of HIV infection, existence of large commercial sex industry and Man sex with Man (MSM), sex with multiple clients and mushrooming growth of Injecting Drug Users (IDUs)<sup>3</sup> extreme poverty, illiteracy, physical and sexual abuse, high prevalence of STDs, mobile population, human trafficking into prostitution, stigmatization, conservative social attitudes, migrant workers, low popularity of condoms<sup>4</sup> in an iconoclastic way.

### **Objectives of the Study**

The principle objective of this paper is to explore the relationship between socio-economic determinants of People Living with HIV/AIDS (PLHIV) and their exposure to different sources of media in the context of having opportunities and accessibilities to HIV/AIDS campaign program in Bangladesh. The specific objectives are as follows.

- 1) to identify the most risk groups who can contract HIV/AIDS
- 2) to examine the level of knowledge and awareness of PLHIV about STDs
- 3) to focus on the scale of media exposure
- 4) to determine the strengths or intensities of HIV/AIDS campaign program in Bangladesh

### **Methodology**

The current study applied quantitative method of data collection. Collecting data through survey has been conducted for seeking the relationship between socio-economic determinants of PLHIV and their exposure to different sources of media. A structured questionnaire was used for collecting data. Data were collected randomly from the victims who were available during the special treatment and counseling day in different NGO clinics and Govt. clinics. The study accounted for 100 People Living with HIV/AIDS (PLHIV) as the respondents for conducting survey. As the research work relates with HIV/AIDS, PLHIV are chosen as the respondents of the current study. Some NGO clinics and govt. clinics working on the treatment and care of PLHIV in Dhaka city were selected as the major sources of getting information about HIV/AIDS campaign program. The field work for the present study was

conducted for a period of two months from February 2013 to March 2013. Bivariate and Multivariate data analysis was done for higher statistical output of the study.

### **Literature**

HIV/AIDS very often poses for a serious public health risk that can be transmitted through sexual and drug related activities and blood transfusion<sup>5</sup> but the epidemic is framed as a repercussion of multiple factors that are intentionally slighted and overlooked in the mainstream media in this globalized world. Referring to media coverage of HIV/AIDS during the first decade in the United States, the media has been ineffective in encouraging an adequate public response to the HIV/AIDS treatment. Information has been presented but usually in non-involving, neutral and objective forms that could be easily and selectively avoided<sup>6</sup>

The workshops held on the role of the media in HIV/AIDS awareness and education in Asian countries like Turkey, Bangladesh, Malaysia Vietnam and Thailand, between 1993 and 1996, revealed that Southeast Asian media are specifically reluctant to make the connection between sexual behavior and HIV/AIDS<sup>7</sup> unless it is portrayed in a sensational and stereotyping panoramic way. The state-owned media in Asia are often controlled by the government authorities who do not care much about HIV/AIDS since many high ranking individuals are not yet infected with the lethal virus. Information campaigns which delivers knowledge and awareness about HIV/AIDS usually aims at inducing knowledge that results in preventing individual behaviors because information and knowledge alone are insufficient to eradicate new HIV/AIDS infections<sup>8</sup>.

Information campaigns are considered to be the most cost effective public response to reduce the number of new HIV infections amidst the absence of an effective vaccine to stop HIV/AIDS transmission and the very expensive medical treatment of HIV positive people. This is confusing whether the media is able to provide effective public health education. “Journalists are not trained to be educators. There is no classroom or controlled setting, no teacher to provide answers to questions or immediately correct misunderstandings”<sup>9</sup>. Mass media are often claimed to misinform the public by suggesting that HIV/AIDS affects certain groups rather than being associated with particular behaviors<sup>10</sup>. The perceived relevance of information on risk behavior in relation to HIV/AIDS will be tremendously affected by whether HIV/AIDS is initially viewed as of concern to individuals, communities, nations, or a mix of them<sup>11</sup>. As Bangladesh is astoundingly located in a geographical and geopolitical

vulnerable situation in terms of spreading HIV/AIDS, the dissemination of national message related with HIV/AIDS control program demands excellent media coverage.

### Results of the Study

The study (Table 1) found that a majority of the PLHIV (25 percent) got themselves engaged in household chores who are simply women. A considerable number of PLHA (16 percent) was identified as unemployed whereas 20 percent of the PLHIV found themselves in various professions. Of the PLHIV 13 percent were counted as migrant workers and service holders respectively in the study. Few respondents (11 percent) were attached to farming though it is an agricultural country. Income is an important factor more enthusiastically connected to the socio-economic status of the people. A large number of PLHIV (69 percent) shows themselves that their monthly income is less than 5000 (BDT). Only 19 percent of the respondents admitted that their income range was 5000-10000 (BDT). The rest of respondents disclosed the fact of having more than 10,000 (BDT). In fact, around 4 percent of the PLHIV confessed that they had an earning source of more than 20,000 (BDT). The average monthly income of the family of respondents was 5650 BDT which disclosed the fact that most of respondents had got HIV infected as a result of migration for earning livelihood, frustration and therefore being engaged in risk practices.

**Table 1: Profile of the PLHIV by socio-economic status**

<b>Characteristics</b>	<b>Male (%)</b>	<b>Female (%)</b>	<b>Total (%)</b>
<b>Employment Status</b>			
Migrant worker	12	01	13.0
Housewife	00	25	25.0
Farmer	11	00	11.0
Service holder	09	04	13.0
Retired	02	00	02.0
Unemployed	14	02	16.0
Other	19	01	20.0
<b>Income (BDT)</b>			
<5000	41	28	69.0
5000 to 10000	16	03	19.0
10000 to 15000	04	00	04.0
15000 to 20000	03	01	04.0
20000 +	03	01	04.0
<b>Education (Level)</b>			
Illiterate	12	13	25.0
Primary	31	8	39.0
Secondary	18	11	29.0
Tertiary	06	01	07.0

<b>Total</b>	<b>67</b>	<b>33</b>	<b>100.0</b>
--------------	-----------	-----------	--------------

(Source : Field Work, 2013)

School attendance among PLHIV was moderately high with more than 70 percent. A certain number of respondents (39 percent) had only primary level schooling. With a view to getting higher education, 29 percent of the PLHIV had participated in secondary school level and only 7 percent of the whole respondents completed tertiary level education.

Table 2 summarizes that more than 90 percent of PLHIV identified IDUs as the most risk group to HIV epidemiology. Male respondents were more likely to female. The child of affected pregnant mother, commercial sex workers and female sex workers were extensively reported by PLHIV to be most risk groups such as 77 percent, 76 percent and 75 percent respectively. Women's response was quite low than men in many respects. Around 56 percent of PLHIV gave consent to commercial blood users who were nearly about to risk. Whereas 44 percent of PLHIV was on behalf of individual with multiple sexual partners, another 22 percent and 2 percent of the PLHIV gave approach to internal migrant workers and others respectively who were regarded as most risk.

**Table 2: Most risk groups to contract HIV\***

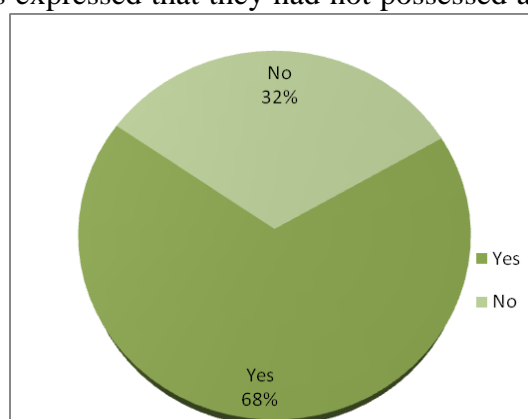
<b>Risk groups</b>	<b>Male (%)</b>	<b>Female (%)</b>	<b>Total (%)</b>
Individual with multiple sexual partners	70.45	29.55	44
Female sex workers	68.00	32.00	75
Commercial sex workers	68.42	31.58	76
Injecting Drug Users (IDUs)	68.48	31.52	92
Commercial blood users	67.86	32.14	56
Child of affected pregnant mother	61.04	38.96	77
Internal migrant workers	71.43	28.57	21

\* Multiple Responses

(Source : Field Work, 2010)

### Knowledge and Awareness about STDs

Only 68 percent of the PLHIV revealed that they had heard about STDs. On the contrary, 32 percent of the respondents expressed that they had not possessed any idea of the STDs at all (Fig. 1).



**Fig. 1: Ever heard of any Sexually Transmitted Diseases (STDs)**

It can be epitomized that the presence of STDs increases the risk of HIV transmission manifold. Table 3 shows that whether PLHIV have a clear idea about different types of STDs and its relation with HIV in terms of sex. Around 65 percent of the PLHIV confirmed that gonorrhoea was a STD while 59 percent of the respondents had knowledge about syphilis. Men were more preferably higher than women in answering about STDs. The percent of percentage of the PLHIV was only 28 who were well aware of the clamedia. Trichomoniasis is one sort of STD which is apparently supported by 15 percent of the respondents. Approximately 5 percent of the PLHIV gave consent about genital sore but the highest number of respondents goes with male respondents which was astounding to some extent.

**Table 3: Awareness of STDs by sex\***

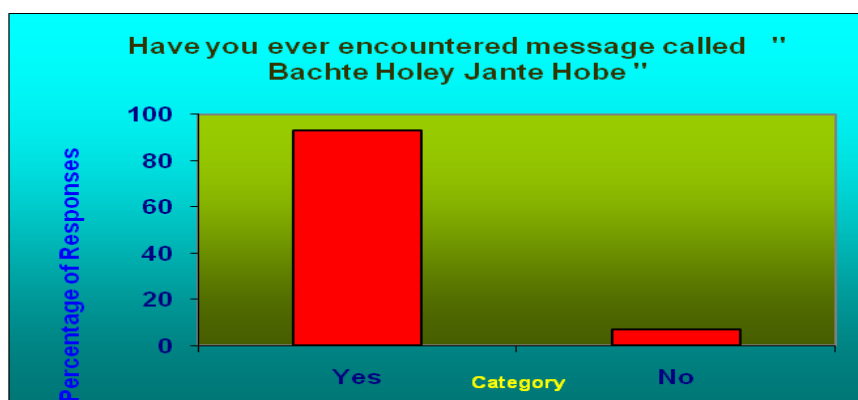
<b>STDs</b>	<b>Male (%)</b>	<b>Female (%)</b>	<b>Total (%)</b>
Syphilis	71.19	28.81	59
Gonorrhoea	70.77	29.23	65
Clamedia	78.57	21.43	28
Trichomoniasis	80.00	20.00	15
Genital Sore	100.00	0.00	4
Other	66.67	33.33	3

\* Multiple Responses

*(Source : Field Work, 2010)*

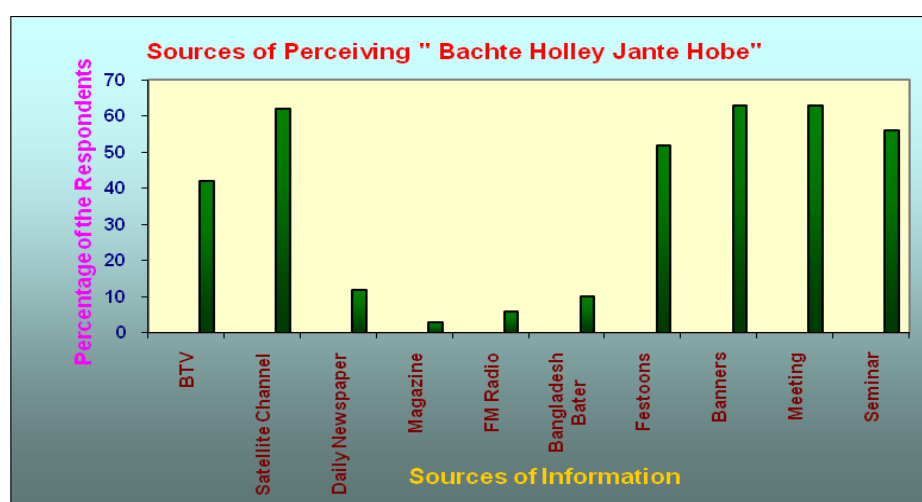
### **Exposure to Mass Media and Health Seeking Information**

Accessibility to knowledge and information as to HIV epedemiology is often channelled to increase people's awareness of the health related risk behavior, which may affect their perceptions and behavior. Awareness and counseling program can make them sure of the severity of the disease and the proper channels of receiving treatment. This is obligatory to pick up that exposure to mass media is very important for PLHIV because of their vulnerability and susceptibility to risk practices. The message "Bachte Holley Jante Hobe" (Fig, 2) is important not only for the PLHIV but also for the general people in order to be conscious of the deadly virus HIV/AIDS and its horrifying ramification. Exposure to electronic and print media was given equally emphasis in order to measure their accessibility to it.



**Fig. 2: Ever encountered message called “Bachte Holley Jante Hobe”**

More than 90 percent (Fig. 3) of the PLHIV received the message called “Bachte Holley Jante Hobe” from satellite channels, banners and meetings. The present study shows that information about HIV prevention could be easily disseminated among general people by arranging awareness program or posting banners. People Living with HIV/AIDS are more exposed to satellite channels (62 percent)



**Fig. 3: Sources of perceiving “Bachte Holley Jante Hobe”**

### **Exposure to Mass Media in Bangladesh**

In this study exposure to mass media was assessed by asking respondents when they usually listen to radio, watch television. It was also asked them that whether they had accessibility to reading newspaper. Of the PLHIV (Table 4), 35 percent of respondents listen to radio on a regular basis. Exposure to radio is higher among female than male respondents. Majority of the respondents (about 15 percent) listen to radio at night while 10 percent of the respondents listen to it other time. Around 90 percent of the PLHIV gave consent about watching television and expressed their positive attitudes toward HIV related national messages.



Though the highest number of respondents (35 percent) are exposed to satellite channel, but 27 percent of the respondents expressed that they are frequently used to watching both satellite and BTV. The peak time for watching TV was regarded night claiming to be free from all kinds of works. More than 50 percent of the frequently TV viewers chose night for watching TV. Around 20 percent of the PLHIV got themselves exposed to watching TV at other time. Watching TV at morning, noon and afternoon was categorized by respondents at 9 percent, 1 percent and 6 percent respectively.

Women are more likely to watch BTV than male. Moreover around 40 percent male PLHIV got used to watching satellite channel which was comparatively higher than female. Around 40 percent of respondents expressed they were used to reading newspaper. The number male respondents was higher than those of female in reading newspaper.

**Table 4: PLHIV by their Media Exposure**

Sources	Male (%)	Female (%)	Total (%)
<b>Radio</b>	32.84	39.39	35.0
<b>Listening to Radio</b>			
Morning	02.99	00.00	02.0
Noon	01.49	09.09	04.0
Afternoon	04.48	06.06	05.0
Night	13.43	15.15	14.0
<b>Television</b>	88.06	87.88	88.0
<b>Watching TV Channel</b>			
BTV	23.88	30.30	26.0
Satellite Channel	40.30	24.24	35.0
Both	23.88	33.33	27.0
<b>Watching TV Channel</b>			
Morning	10.45	06.06	09.0
Noon	01.49	00.00	01.0
Afternoon	04.48	09.09	06.0
Night	50.75	57.58	53.0
<b>Reading Newspaper</b>	49.25	15.15	38.0

(Source : Field Work, 2010)

### **Exposure to HIV and AIDS Related Campaign Program**

More than 90 percent (Table 5) of the PLHIV proclaimed that they had ever heard/watched campaign on HIV/AIDS from the reliable sources of both electronic and print media. Men are more likely to expose to media than women. Almost 60 percent of the PLHIV received

information on HIV/AIDS from satellite channels but 52 percent of the respondents supported banners for getting information. Around 46 percent of the respondents got the message on HIV/AIDS from BTV, only 12 percent and 9 percent of the PLHIV heard the message from Bangladesh Betar and FM radio respectively. The other sources of print media such as festoon, daily newspaper and magazine were reached by PLHIV characterizing 44 percent, 20 percent and 6 percent respectively. Men were almost likely to response than women in this media based multiple responses questions.

**Table 5: Response to HIV and AIDS Control Program\***

Characteristics	Male (%)	Female (%)	Total (%)
Ever heard/watched any campaign on HIV/AIDS	94.03	90.91	93
<b>Sources of information</b>			
BTV	50.75	36.36	46
Satellite channel	58.21	57.58	58
Daily newspaper	22.39	15.15	20
Magazine	4.48	9.09	6
FM radio	10.45	6.06	9
Bangladesh Betar	10.45	15.15	12
Festoons	47.76	36.36	44
Banners	58.21	39.39	52
Others	10.45	3.03	8

\* Multiple Responses

(Source : Field Work, 2010)

### Socio-economic Status and Accessibility to Information

**Tables 6: Summary table of cramer's V and chi-square on media exposure**

Variables	Media Exposure		
	Listening to Radio	Watching Television	Reading Newspaper
Sex	$\chi^2=.418$ , df 1	V=.003	$\chi^2=10.914^{**}$ , df 1,
Education	V=.327**	V=.227	V= .461***
Income	V=.170	V=.165	V= .268
Marital status	V=.162	V= .065	V=.324*
Occupation	V=.212	V= .165	V=.320

P= 0.05\* P= 0.01\*\* P= 0.001\*\*\*

The table six (6) of Chi-square and V values shows that sources of exposing mass media are significantly associated with three important variables, sex, education and marital status.

Education is found to be significantly associated with exposure to radio ( $P < 0.05$ ) and newspaper ( $P < 0.001$ ). It is found that more female are exposed to radio listening and more male are exposed to television watching. Around 40 percent of the respondents read newspaper; this lower rate of exposure to newspaper reading may be affected by the low level of knowledge of PLHIV. Sex has been significantly associated with exposure to newspaper reading ( $P < 0.01$ ). It is found that more men tend to read newspaper than women. Such type of exposure to newspaper reading may be affected by the level of knowledge and curiosity of knowing the present condition of markets, politics, economy, environment and health sectors etc. Moreover marital status has a coherent relation with newspaper reading ( $P < 0.05$ ). Income and occupation do not show any significant relation with different variables of mass media.

From sociological point of view it can easily be expressed that the exposure of mass media is determined by socio-economic statuses of PLHIV. Both print and electronic media have a coherent relation with educational status of the concerned respondents. Education, a dominant character of the lifestyles and status, affects many aspects of life including demographic and health behavior. Many studies show that people with formal education have strong influences on health behavior, attitudes and practices. More than sixty percent People Living with HIV/AIDS (PLHIV) are extremely exposed to satellite channels focused in the present study. This statistic clearly shows the level of affordability of having electronic devices like Radio, TV and the cost management of satellite channels which is intimately connected with the economic statuses of the study people.

### **Recommendations**

For overcoming the challenges and enriching the prospects of media coverage in Bangladesh, some specific strategies can be artistically recommended in relation with the dissemination of national messages.

- ❖ Exposure to risk free practices such as safe sex relation, pure blood transfusion can act positively for ameliorating the health hazards of PLHIV.
- ❖ Besides satellite channels, BTV and radio exposure should be accelerated for spreading the texts related with HIV/AIDS at national level.
- ❖ Since the whole country is not under electricity service, exposure to newspaper can be increased for reaching the general people of remote regions across the country.
- ❖ The language of messages should be clearly oriented with health risks and preventive measures of HIV/AIDS in the context of Bangladesh.

- ❖ The state might have directed and played a multidisciplinary arrangement for reshuffling the awareness program of HIV/AIDS related issues taking the matter of strengthening the role mass media into account.
- ❖ Though the level of HIV/AIDS is still less than 1% in Bangladesh, various organizations along with the direct supervision and monitoring of government should take the protagonist role in overcoming the impending HIV/AIDS related health challenges countrywide.

### **Conclusion**

The study found that 88 percent of the PLHIV frequently watched TV and only 35 percent of the respondents were exposed to radio. The electronic media predominates over the print media in the present study. Only a considerable number of the respondents read newspaper. This evidence proves that people with secondary and primary education are not highly exposed to reading newspaper. Only 7 percent of the PLHIV received tertiary level education, an important sign of determining the rate of newspaper readers. More than 90 percent of the respondents have either heard or watched any campaign of HIV/AIDS. About 58 percent of the respondents receive the information from satellite channels because it covers the highest percentage of watching television. This analysis proves that exposition to electric media has augmented the level of awareness of PLHIV. A large number of the respondents regard festoons and banners as the important sources for disseminating HIV knowledge.

### **References**

1. UNAIDS 2004. AIDS epidemic update 2004. Geneva, Switzerland: UNAIDS
2. UNAIDS 2004. AIDS epidemic update 2004. Geneva, Switzerland: UNAIDS
3. Amanullah, A.S.M. 2006c. 'Bangladesh and HIV Epidemic: A Fatal Silence. Gender and Human Resources for Health in South Asia: Challenges and Constraints'. University Grants Commission of Bangladesh (UGC) and Canadian International Development Agency (CIDA), Canada. Dhaka, 2006
4. Amanullah, A.S.M. 2002, 'A Socio-cultural Analysis of Sexual Risk and Disease in a Developing Country: The failure of KAP-based Theories Applied to Controlling HIV/AIDS in the Bangladeshi Sex Industry'. PhD Dissertation, The University of New South Wales, Sydney, Australia.

5. Kotulak, R. 1993. "Sorting through the chaff," in S, Ratzan. 89 - 99.
6. Ratzan, S. ed. 1993. AIDS: Effective Health Communication for the 90's. Boston: Taylor and Francis.
7. Wolffers, I. 1997, "Culture, Media and HIV/AIDS in Asia," The Lancet, 349
8. Frolich and Vazquez- Alvarez, 2009.
9. Aggleton, P., P, Davies and G, Hart. eds. 1991, AIDS: Response, Interventions and Care. London: Falmer Press.
10. Aggleton, P., P, Davies and G, Hart. eds. 1992, AIDS: Rights, Risks and Reason. Washington DC: Falmer
11. Patton, C. 1990, Inventing AIDS. London: Routledge.

# Sociocultural Constraints, Sexual Violence and Dropouts at School Level: A New Challenge for Bangladesh

**Thamina Khan<sup>1</sup> and Masum Billah<sup>2</sup>**

**Abstract :** This paper is about to sort out the sociocultural barriers of school going female children and its association with dropouts in Bangladesh. Primary data are collected using social survey method as the situation demands. Results of the study reveal that social insecurity, abusive expressions, objectionable comments and sexual violence are primarily liable for increasing the level of dropouts in educational institutions, even if socio-economic factors. The state does not particularly follow any strict policy to handle the horrifying scenario of sexual violence in educational institutions. The study basically accounts for the complexities of access and the interactive, dynamic nature of socio-cultural factors which may contribute to dropping out in Bangladesh.

**Key Words:** Constraint, Sexual violence, Dropout, Harassment, Persecution, Social insecurity

## **Introduction**

Enmeshed with poignant social problems and cultural obstacles, the way of living of school going girl children has been challenged over time in Bangladesh. A series of events concerned with sexual harassment and eve-teasing, have already been occurred in Bangladesh which might be claimed as the apotheosis of violence against school going girls. Bangladesh is one of the most densely-populated countries in the world, with about 160 million people in a land area of 147,570 square kilometers<sup>1</sup>. Bangladesh is a land of immense beauty and potential situated in South Asia bordering India, Myanmar and the Bay of Bengal. It is largely a flat deltaic country formed by the confluence of great river systems of the Padma (Ganges), the Brahmaputra and the Meghna. Bangladesh is a land of mosaic of green fields striped by stretches of silvery waters. Dhaka the capital city of Bangladesh is chosen as the site area of the study as people from different parts of the country reside here and continues schooling for their children. The findings of the study could very easily be applicable for all over Bangladesh.

A conglomeration of horrifying incidents has been occurred all over Bangladesh intensifying the rate of girl's violence at school level. The successive trend of women's empowerment prevailed across the world is yet to touch people maneuvered by social dogmas and conservative attitudes. The successive trend of women's empowerment prevailed across the world is yet to touch people maneuvered by social dogmas and conservative attitudes.

---

1. Tahmina Khan, Associate Professor, Dept. of Sociology, Dhaka International University, Dhaka, Bangladesh.

2. Masum Billah, Lecturer, Department of Sociology, Dhaka International University, Dhaka, Bangladesh.

**Correspondence to:** Tahmina Khan, Email: khan.tahmina24@yahoo.com

This is a normal scenario that the inquiry committee is often formed to ensure the actual verdict of the accused person if it occurs at institutional level. At the family level the case is sometimes filed against the criminal, to some extent it is not actually done because of social security related complexity. The ultimate goal has not been achieved at all. In order to accelerate the level of judgment and ensure instant family support a timeframe is only circumscribed for the victimized person. The real judgment is not completed properly in many spheres of social life. To avoid the repercussion of such hectic violence, a constructive and action-oriented policy needs to be boosted up ensuring the implementation of laws and the confirmation of higher education in Bangladesh.

### **Objectives of the Study**

The major objective of the research is to explore the socio-cultural factors and perceived barriers to girl attendance in schools in Bangladesh. It also attempts to focus on socio-economic determinants and its association with girl enrollment rates. The study has focused to identify the patterns of teasing and approaching sexual abuse in relation with violent behavior. It seeks to observe whether school going girl children have trust to social security promoted by school authority. The existing gaps between teacher and student and parents in relation with behavioral patterns have also been focused in the research.

### **Methodology**

The study applies quantitative method of data collection. Samples have been selected purposively. School going girl children of secondary level are chosen as the target group of the study. The survey method is used for collecting quantitative data. The questionnaire includes both structured and semi-structured questions to get the desired information. The field work for this study was carried out during February-March 2013 in 6 different schools in Dhaka city. Survey has been administered among 180 students who are purposively selected. Each school covers 30 students for generalizing the study findings. The study objectives and overall plan of fieldwork are initially discussed with key informants and school teachers. Considering the issues of security and confidentiality, the researcher has to take the institutional permission at each school for carrying out the field work. The data is analyzed by using uni-variate statistical table.

## **Literature**

In developing countries, the problem is particularly severe because the violence is, at times, extreme and takes place in conjunction with an increased risk of HIV infection in places where HIV rates are high. In an educational setting in Ecuador, 22 percent of the adolescent girls reported being victims of sexual abuse<sup>2</sup>. A qualitative study in Addis Ababa, Ethiopia found that bullying and attempted rape were factors in low female enrollment rates and high dropout rates from secondary schools. There was public awareness and concern about this, but many families and schools felt helpless to bring about change. Both male and female respondents in this study identified girls' "dress" and their general behavior as a cause of sexual violence. Respondents and researchers both noted that school crowding and teacher's apathy further contributed to violent behaviors in schools<sup>3</sup>.

African Rights, a UK-based NGO, reported that sexual violence against girls in schools is "an extremely grave problem" in many African countries, including South Africa, Zambia, Sudan, Nigeria, and the Democratic Republic of Congo<sup>4</sup>. The report discusses a series of sexual abuse incidents perpetrated by male students or teachers as well as outsiders against female students from primary schools to universities. Student clubs and organizations might have been used as safe domain for sexual harassment and abuse against girl students, with alcohol consumption considered to be contributing factor in many cases.<sup>5</sup>

## **Premarital Sex and Reproductive Health: Vulnerabilities and Risks**

In U.S. schools, both student-to-student and teacher-to-student sexual harassment have been widely reported<sup>6</sup>. In the United Kingdom, research in four co-educational schools with children aged 10 and 11 and 14 and 15 found that girls routinely mentioned boys calling girls sexualized names, flicking their bra straps, looking up their skirts, and grabbing or fondling, and that boys were regularly called "gay" and other sexually laden terms that the students perceived to be derogatory<sup>7</sup>. A study of the sexual and reproductive health status of 400 in-school and out-of-school adolescents in Dodowa, Ghana<sup>8</sup> found that adolescent premarital sexual activity is common (54 percent of the never-married male students and 32 percent of the never-married female students reported sexual experience). While both female and male adolescents reported being forced to have sex, in-school female adolescents were more susceptible to forced sex, and junior secondary school female adolescents were the most susceptible. Teachers accounted for 5 percent of those forcing female students to have sex and one-third of the 50 teachers interviewed in the study reported that they knew one or more teachers who had sex with students. Most of these relationships were never reported to school



authorities, including those involving coercive sex. Some described these relationships to be mutual ones based on sex in exchange for marks, money, or love. The authors argue that the simultaneous practice of unprotected and multiple partner sexual behavior by teachers may put their sexual and reproductive health at risk, as well as that of their partners.

The study had examined the prevalence of sexual abuse, including rates of sexual activity, whether respondents had been forced or coerced to have sex and, if so, who coerced them and whether or not condoms were used<sup>9</sup> While the study did not include a representative sample for Botswana, it included interviews with 40 teachers, parents, or community leaders. The findings indicated that 38 percent of the girls questioned reported that they had been touched in a sexual manner without their consent, while 17 percent reported having had sex, with 50 percent of them saying that it was forced. Thirty-four percent of the students said they had sex for money, gifts, or favors. Of those sexually active, 48 percent said they had never used a condom. Most of the sexual harassment, unwanted touching, and forced sex came from peers, i.e., boys of the same age as the girls surveyed.

In another study of sexual violence in Botswanan schools, 560 students were surveyed and 67 percent of the girls reported sexual harassment by teachers<sup>10</sup>. Harassment ranged from pinching and touching to pressure for sexual relations. Twenty percent of the respondents reported being asked by teachers for sexual relations, and half reported fearing repercussions of poor grades and performance records if they did not. Sixty-eight percent of sexual harassment incidences happened in junior secondary schools, 18 percent in senior secondary schools, and 14 percent in primary schools. This has translated into the absence of procedures and channels for reporting<sup>11</sup>. Building on their previous work in Zimbabwe Leach and her colleagues conducted further research and attempted to bridge the gap between research and action in addressing the issue of abuse of girls in African schools. In Ghana and Malawi, they reported findings similar to those in Zimbabwe: girls were routinely subjected to aggressive sexual advances from older male students and male teachers and to potentially damaging gendered practices in schools. Sexual aggression went largely unpunished and dominant male behaviors by both students and teachers were not questioned. The Leach report discusses the impact of teacher abuse on the quality of the learning environment, the extent to which abusive behaviors feed on poverty and ignorance, and the ambivalent attitude of some parents, teachers, and the girls, themselves, toward teachers having sexual relationships with school girls. The major determinants which mainly influence the level of dropping out in

Bangladesh are artistically picked up as the apotheosis of conceptual framework of the study (Fig 1)

### Conceptual Framework

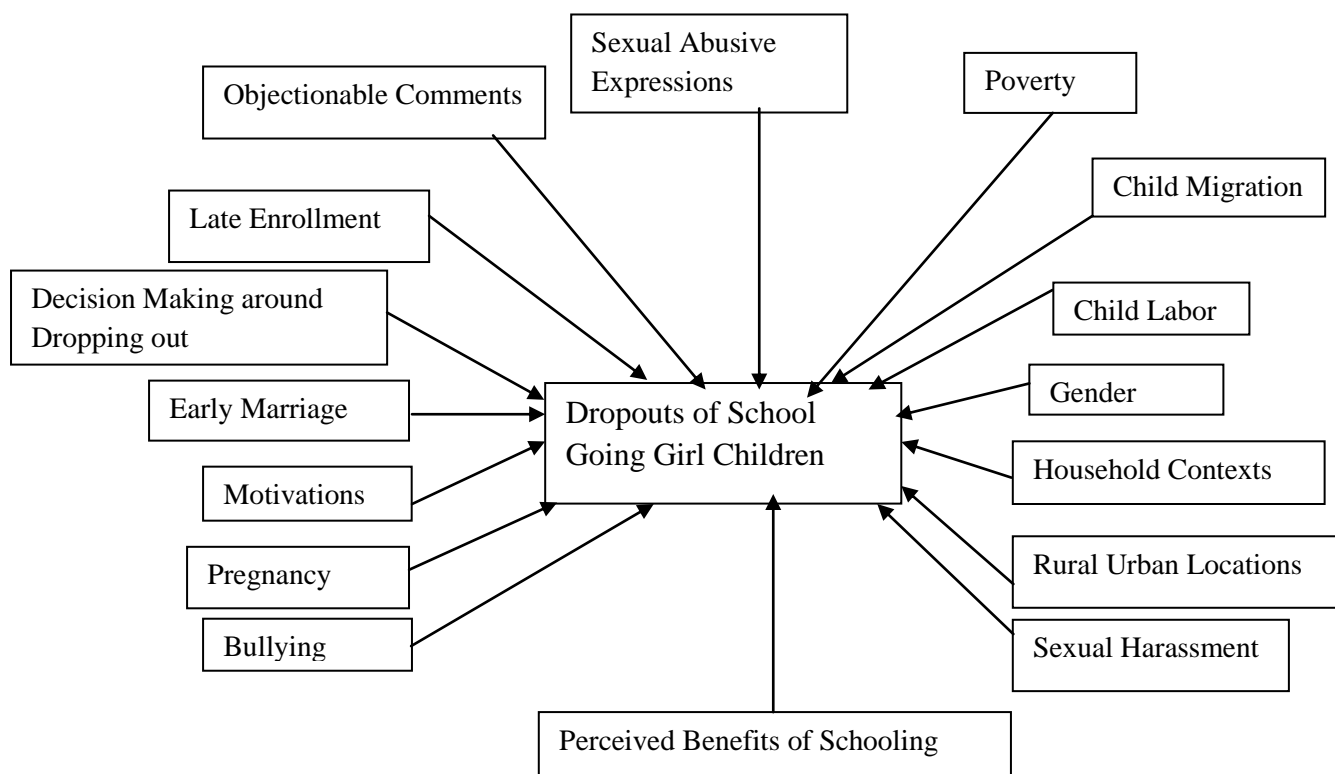


Fig 1: Key indicators related with dropouts of school going girl children

### Discourse and Sexuality: Theoretical Relevance

Power often determines the ability of dominant class who want to exercise their will over the subordinate class taking the opportunity of their shortcomings and backdrops. Foucault at first attacks the conventional notion of power and asserts that power is something which is performed, something more like a strategy than a possession<sup>12</sup>. Power must be analyzed as something which circulates, or as something which only functions in the form of chain. Power is employed and exercised through a network like organization. Individuals are the vehicles of power, not its points of application<sup>13</sup>. Power is regarded as a chain or net, which is a system of relations spread throughout the society. Individuals should not be seen as the recipients of power, but as the place where power is enacted and resisted. Thus his theorizing of power forces us to conceptualize not only power itself but also the role that individuals play in power relations whether they are simply subjected to oppression or whether they actively play role in the form of their relations with others and with institutions<sup>14</sup>. In a disciplinary scheme Foucault also talks about the way that women's bodies and sexualities

are shaped by social pressures. Women's bodies, particularly middle-class women's bodies have been the subject of a vast array of different practices and discursive regimes.

Risk is conceptualized as "a systematic way of dealing with hazards and insecurities induced and introduced by modernization itself".<sup>15</sup> Beck's distinction between 'natural' and 'artificial' hazards insists that in the age of modernity we must confess that we are still subject to hazards originating in nature. The way theory has been flourished and set in my research is that risk practices are a great concern for enhancing health related complexities. Risk perception tremendously varies from person to person, society to society in this new knowledge based and technically well-equipped postmodern society. The nature and content of risk has turned into a new form and affably attached the changing practices in this global cultural setting. Girl children are not at all well aware of the high risk practices in our socio-cultural setting. Even if they can not perceive the ramification of risky activities let alone health hazards.

## Results

A series of multiple obstacles could be outlined for understanding the scenario of current girl enrollments in different schools in Dhaka. Table 1 states that approximately 37 percent of female students regard financial crisis as one of the main barriers for not to get enrollment in schools. 20 percent girl students consider transportation cost and late enrollment as the liable factors for less number of enrollments in educational institution which again flourishes the rate of drop-out in Bangladesh. Long time studying method and distance are explained as the two factors claiming 10 percent and 12.78 percent by the respondents in the study.

**Table 1: Socio-economic obstacles of girl students**

<b>Socio-economic obstacles</b>	<b>Frequency</b>	<b>Percentage (%)</b>
Financial crisis	66	36.67
Long time studying method	18	10.00
Distance from home	23	12.78
Transportation costs at school	36	20.00
Late enrollment at school	37	20.56
<b>Total</b>	<b>180</b>	<b>100.00</b>

Table 2 shows that 43.33 percent of the respondents report social insecurity behind not to get interested in schooling. Early marriage is considered as barrier of schooling by around

19percent of the female students. About 15 percent of the respondents are not aware of schooling. Low education, superstitious attitudes and household contexts are claimed as cultural barriers by 8.89 percent, 10.56 percent and 3.89 percent of the target group respectively.

**Table 2: Socio-cultural barriers of girl students in schooling**

<b>Socio-cultural barriers</b>	<b>Frequency</b>	<b>Percentage (%)</b>
Lack of awareness	26	14.44
Lack of social security	78	43.33
Low education	16	08.89
Superstitious attitudes	19	10.56
Early marriage	34	18.89
Household contexts	07	03.89
<b>Total</b>	<b>180</b>	<b>100.00</b>

(Source : Field Work, 2013)

Approximately 32 percent of the respondents (Table 3) experienced sexual expressions while 30 percent of the female students faced bullying in their respective educational institutions. About 23 percent of the studying people got victimized by sexual harassment at their outset of school life which definitely discourages enrollments intensifying the level of drop-out across the country. 13.89 percent of the victims claimed stalking as one of their barriers for school enrollment.

**Table 3: Experiences encountered by girl students at educational institution**

<b>Experiences at educational institutions</b>	<b>Frequency</b>	<b>Percentage (%)</b>
Ever experienced by persecution	25	13.89
Ever felt by sexual expressions	58	32.22
Ever victimized by sexual harassment	42	23.33
Ever encountered by harassment	55	30.56
<b>Total</b>	<b>180</b>	<b>100.00</b>

(Source : Field Work, 2013)

Table 4 indicates that 31 percent of the female students experience sexual abusive expressions by commuters at their way of school whereas 21 percent of the students got sexually harassed by their teachers in the respective educational institutions. Objectionable comments thrown by their classmates are reported to be around 20 percent of the target

people. Persecution, harassment and unexpected behavior are addressed by 16.11 percent, 06.67 percent and 06.11 percent in the study. Grooming at family level is not completed and addressed in a proper way. The study has outlined that girls are to encounter objectionable attitudes from their very nearest ones whom they regard as their friends or teachers in most cases in social life.

**Table 4: Problems faced by girl students at educational institution**

<b>Problems</b>	<b>Frequency</b>	<b>Percentage (%)</b>
Objectionable comments by classmates	34	18.89
Sexual abusive expressions by commuters	56	31.11
Sexual harassment by teacher	38	21.11
Persecution	29	16.11
Harassment	12	06.67
Unexpected behavior from close friend	11	06.11
<b>Total</b>	<b>180</b>	<b>100.00</b>

*(Source : Field Work, 2013)*

## **Discussion**

About 37 percent of the school going girl believe that financial crisis is a major factor for maintaining the current educational expenses in schools. A vital number of poorer sections of are quite deprived of the minimum facilities of education, though few attempts are taken to intensify girl's education in Bangladesh. Around 21 percent girl students get enroll in schools late which again shows their both physical and mental maturity before the completion of higher education. Transport cost (20%) is another attention for school going children in Dhaka which acts as a barrier in schooling set beside other expenses. The hurdles around socio-economic standpoint for schooling are extreme in middle class families in Dhaka. Besides a number of social barriers, the cost of materials related with education is many folds high as it was earlier. For the lower section of society, the continuing of educational expenses is a stanch in their day to day struggling life.

Being a very sensitive issue, around forty three percent of the girl students feel insecurity for having education from schools in Bangladesh though they are often confirmed with risk free life. A certain number of populations are not aware of their level of excellence for getting standard education from institutions which again discourages enrollment rate setting the country in a more degradable situation. Abusive acts range from sexist jokes to pressuring

students to engage in sexual relations in many educational institutions ever experienced by the girl students keeping their life into risk and uncertainty. Whereas about 30 percent of the girl students encountered sexual expressions from commuters in their studying life, another 19 percent faced objectionable comments from their classmates. In Cameroon, a study of sexual abuse in schools in the city of Yaoundé revealed that about 16 percent of the 1,688 surveyed students reported being abused<sup>16</sup>. The scenario completely focuses the level of vulnerabilities of women in educational sectors. The promise of good grades or the threat of failure was used by some male teachers to achieve sexual relations with students. In some instances, students engaged in sexual relations with teachers for money. School administrators often dismissed such cases by blaming the students or simply encouraging them to “stay away” from harassing teachers. Approximately 21 percent of the respondents are victims of sexual harassment by their teacher. Although 83 percent of teachers considered student–teacher relations to be a big problem in Botswanan schools, the country code of conduct for teachers remains silent on sexual harassment, and the Ministry of Education does not have a formal policy to address it<sup>17</sup>.

The dynamic nature of both social and cultural factors might contribute a lot to the level of dropouts in Bangladesh. Rather, much of the available literature identifies one factor (or possibly more) leading to dropouts, which is identified as the final push or pull out of school. Lots of reasons like child marriage, persecution, harassment and unexpected behavior from the close ones invigorate the problem of dropouts in Bangladesh. A series of issues which go with legal framework should be redesigned and formulated to bring a peaceful environment for reducing girl’s violence in educational institutions in Dhaka. Set besides emphasizing the socio-cultural factors at family level, people could be built up from moral standpoint which again reduces the level of crimes in schools. Legal issues should be regulated with the direct supervision of government of the country. Local monitoring team can act as a visiting team to avoid the instant hassles in schools. A constructive policy should be reoriented and reformulated in order to reshuffle the administration to keep an alarming invigilation over the students. An astounding interplay of social, cultural and legal initiatives can only ensure the violence free schooling life dwindling dropouts and flourishing enrollments at secondary level in Bangladesh.

## Conclusion

In spite of having lots of ambivalent and mixed propositions about the very nature of sexual violence in educational institution, Bangladesh is still a country which basically underscores the myriad of socio-economic and socio-cultural factors contributing tremendously the image of dropout. Occurrences related with sex and abusive tasks are frequent and natural day to day phenomenon in different schools in Bangladesh raising again the question of insecurity and health risk. The entire physical, mental and social wellbeing of an individual in all matters relating to the sexual and reproduction should be the utmost concern of government and all stake holders in population since girls are the producer of human offspring and the future of a nation is subject to their sound sexual and reproductive health. All sorts of heinous tasks and anti-sociocultural elements try to keep the ball rolling as supposed to flourish the level of dropout in Bangladesh.

## References

1. Population Reference Bureau, 2010 *World Population Data Sheet*, Population Reference Bureau, Washington, DC, cited 2012 July 18. Available at [http://www.prb.org/pdf10/10wpds\\_eng.pdf](http://www.prb.org/pdf10/10wpds_eng.pdf)
2. World Bank 2002 "Ecuador Gender Review: Issues and Recommendations." A World Bank Country Study. Washington, DC: The International Bank for Reconstruction and Development/World Bank.
3. Terefe, Dereje and Desere, Mengistu. 1997. "Violence in Ethiopian Schools: A Study of Some Schools in Addis Ababa." In *Violence at Schools: Global Issues and Interventions*, edited by T. Ohsako. Paris: UNESCO International Bureau of Education.
4. Hallam, 1994:1. "Crimes without Punishment: Sexual Harassment and Violence against Female Students in Schools and Universities in Africa." Discussion Paper No. Four. London: Africa Rights.
5. Hallam, 1994:2. "Crimes without Punishment: Sexual Harassment and Violence against Female Students in Schools and Universities in Africa." Discussion Paper No. 4. London: Africa Rights.
6. Stein, Nancy; Marshall, L and Tropp, Linda R 1993. "Secrets in Public: Sexual Harassment in Our Schools." Center for Research on Women Report CRW 5. Wellesley, MA: Wellesley Centers for Women.

7. Duncan, N. 1999. *Sexual Bullying: Gender Conflict and Pupil Culture in Secondary Schools*. London: Routledge.
8. Afenyadu, Dela, and Goparaju, Lakshmi 2003. "Adolescent Sexual and Reproductive Health Behaviour in Dodowa, Ghana." Washington, DC: CEDPA.
9. Botswana Gazette 2000
10. Rossetti, S. 2001. *Children in School: A Safe Place?* Botswana: UNESCO.
11. Leach, Fiona; Machakanja, Pamela and Mandoga, Jennifer. 2000. Preliminary Investigation of the Abuse of Girls in Zimbabwean Junior Secondary Schools. Education Research Paper. London: Knowledge & Research, Department for International Development.
12. Foucault, Michel 1978. *The History of Sexuality, Vol.1: An Introduction*, (trans. Robert Hurley), New York: Pantheon.
13. Foucault, Michel 1980. *Power/Knowledge: Selected Interviews and other Writings 1972-1977*, (ed. C. Gordon), Brighton: Harvester
14. Mills, Sara 2007. *Michel Foucault*. Rutledge Taylor and Francis Group. London and New York.
15. Beck, Ulrich 1992. *Risk Society: Towards a New Modernity*. SAGE
16. Mbassa, Menick, Daniel. 2001. "Les Abus Sexuels en Milieu Scolaire au Cameroun." Presented at the Committee on the Rights of the Child Day of General Discussion "Violence Against Children within the Family and in Schools," Sept. 28, Geneva, Switzerland.
17. Rossetti, S. 2001. *Children in School: A Safe Place?* Botswana: UNESCO.



# Class Consciousness of Workers in Garments Industry in Bangladesh: Marxian Perspective

Abdur Rahim Mollah\*

**Abstract:** Class consciousness is a very polemical issue in third world perspective. Socio-economic and socio-political factors greatly influence the frequently occurred movements in garments industry in Bangladesh. The study used qualitative method of data collection for the content analysis. Data were collected from different secondary sources. Results of the study reveal that the level of class consciousness of workers is astoundingly shaped by the image of so called lumping proletariat, political big shots and petty bourgeoisie.

*Key Words:* Class, Class Consciousness, Movements, Lack of Consciousness

## Introduction

Marx's view of class consciousness was that the working class had to have one single vision: that of believing the wealthy were their oppressors. It was with the hope of this vision that Marx felt the working class would naturally rise up against the wealthy owners and demand equality. In Marxian perspective, the revolution would destroy capitalism and governments, which would be replaced by a socialistic collective where all were equal in ownership and rewards of production. The exploitation of the working class is seen as a catalyst for change. Marx believed that the capitalistic system of the time could and should be destroyed, and Marx called for a revolution by the working-class members. However, before the revolution could occur, Marx felt that the working class first needed to develop what is known as class consciousness. This is a subjective awareness of common vested interests and the need for collective political action to bring about social change. Simply put, the workers needed to see themselves as one unit and, together, could revolt and change their working conditions. A number of factors account for the shift in clothing manufacture from the first world to the developing world and to the drastic restructuring of this major world industry which presently employs over 7.5 million people worldwide.<sup>1</sup> Unlike many other industries, clothing manufacture is not highly automated nor has technology developed to replace the individual sewer. For this reason production is highly labor intensive and hence the payment to garment workers are crucial for determining the cost of the finished article.

---

\* Abdur Rahim Mollah, Assistant Professor, Department of Sociology, Dhaka International University, Dhaka, Bangladesh.

**Correspondence to:** Abdur Rahim Mollah, abdurrahimsust@yahoo.com

The removal of trade barriers and the development of manufacturing in the third world have meant that there is a 'continuing search for greater profit by textile and clothing manufacturers, which depends on finding and exploiting the cheapest labor in developing nations, as well as indigenous immigrant populations at home'. The huge disparity in wage levels worldwide is the driving force behind the globalization of the garment industry.

The garments industry of Bangladesh deserves the tremendous position in terms of earning a handsome amount of foreign currency and gracing the Gross Domestic Product (GDP) every year. The output of this highly prospective sector greatly depends on the cheapest labor of hard core people of the country. The facilities and opportunities of labor class of this industry are not sufficient for their sound living standard as well as not for making any revolution against the so called bourgeoisie class in Bangladesh.

### **Literature**

The manufacture of clothing has historically been crucial to the industrial and economic development of numerous countries. In Britain, for example, 'the development of the textile industry set in motion the Industrial Revolution'.<sup>2</sup> In the last few decades the clothing industry has declined in almost all first world countries, as garment factories have multiplied across the developing world. Fashion and clothing have, as Entwistle argues, 'played a significant role in global relations between nations' and it is increasingly the case that the garment industry is predominantly in the third world, providing the fashion industries of the first world with clothing.<sup>3</sup> Developing countries doubled their share of world clothes exports from thirty per cent in the early 1970s to over sixty per cent by the mid-1990s.<sup>4</sup> Studies of the globalization of the textile, clothing and footwear industries indicate that the leading country in the manufacture of clothing is China where it is a crucial industry in the economic development process.<sup>5</sup> China exports twenty-nine per cent of the world's garments and is increasing its share yearly. The next largest exporter, Italy, exported just a third of that amount. Although historically a leader in the fashion and garment industries, Italy is declining in importance as the developing economies of Asia and North Africa as well as poorer European countries like Poland, Romania and Turkey become larger exporters of clothing. The clothing industry in the developing countries of Asia, the Pacific, Africa and South America are likely to be crucial to their economic growth in the next decades. A number of factors account for this shift in clothing manufacture from the first world to the developing world and to the drastic restructuring of this major world industry which presently employs over 7.5 million people worldwide.<sup>6</sup> While the developing world is providing

relatively low paid labour for the garment industry, migrant workers in the developed world are employed in a flexible and largely informal garment manufacturing economy where they work in small sweatshops or in their own homes.

### **Objectives of the Study**

The study explores the level of class consciousness of garments workers in Bangladesh. It also attempts to show the relationship between the socio-economic statuses of labor class and their lack of consciousness. It further studies the role of state in controlling the class movements occurred in garments sector.

### **Methodology**

The study is conducted on the basis of content analysis of several books, journals, magazines and papers for understanding the level of consciousness of garments workers in Bangladesh. Qualitative method is employed for collecting data derived from different secondary sources. Data analysis has been done by summarizing and paraphrasing the key ideas of class conflict in relation with the major objective of the study.

### **Class Struggle and Class Consciousness: Bipolar Politics in Modern Industrial Society**

Of all the classes that stand face to face with the bourgeoisie today, the proletariat alone is a really revolutionary class. The other classes decay and finally disappear in the face of Modern Industry; the proletariat is its special and essential product. The lower middle class, the small manufacturer, the shopkeepers, the artisans, the peasant, all these fight against the bourgeoisie, to save from extinction their existence as fractions of the middle class. They are therefore not revolutionary, but conservative. If by chance they are revolutionary, they are so only in view of their impending transfer into the proletariat, they thus defend not their present, but their future interests, and they desert their own standpoint to place themselves at that point of the proletariat.<sup>7</sup>

In the social production of their existence, men inevitably enter into definite relations, which are independent of their will, namely relations of production appropriate to a given stage in the development of their material forces of production. The totality of these relations of production constitutes the economic structure of society, the real foundation, on which arises a legal and political superstructure and to which correspond definite forms of consciousness. The mode of production of material life conditions the general process of social, political and

intellectual life. It is not the consciousness of men that determines their existence, but their social existence that determines their consciousness.<sup>8</sup>

Marx's class theory rests on the premise that "the history of all hitherto existing society is the history of class struggles." According to this view, ever since human society emerged from its primitive and relatively undifferentiated state it has remained fundamentally divided between classes who clash in the pursuit of class interests. In the world of capitalism, for example, the nuclear cell of the capitalist system, the factory, is the prime locus of antagonism between classes--between exploiters and exploited, between buyers and sellers of labor power--rather than of functional collaboration. Class interests and the confrontations of power that they bring in their wake are to Marx the central determinant of social and historical process.

Marx's analysis continually centers on how the relationships between men are shaped by their relative positions in regard to the means of production, that is, by their differential access to scarce resources and scarce power. He notes that unequal access need not at all times and under all conditions lead to active class struggle. But he considered it axiomatic that the potential for class conflict is inherent in every differentiated society, since such a society systematically generates conflicts of interest between persons and groups differentially located within the social structure, and, more particularly, in relation to the means of production. Marx was concerned with the ways in which specific positions in the social structure tended to shape the social experiences of their incumbents and to predispose them to actions oriented to improve their collective fate.

To Marx, the basis upon which stratification systems rest is the relation of aggregates of men to the means of production. The major modern classes are "the owners merely of labor-power, owners of capital, and landowners, whose respective sources of income are wages, profit and ground-rent." Classes are aggregates of persons who perform the same function in the organization of production. Yet self-conscious classes, as distinct from aggregates of people sharing a common fate, need for their emergence a number of conditions among which are a network of communication, the concentration of masses of people, a common enemy, and some form of organization

The same mode of reasoning that led Marx to assert that the working class was bound to develop class consciousness once the appropriate conditions were present also led him to contend that the bourgeoisie, because of the inherent competitive relations between capitalist producers, was incapable of developing an overall consciousness of its collective interests.

The classical economists picture the economic system of a market economy as one in which each man, working in his own interest and solely concerned with the maximization of his own gains, nevertheless contributes to the interests and the harmony of the whole. Differing sharply, Marx contended, as Raymond Aron has put it, that "each man, working in his own interest, contributes both to the necessary functioning and to the final destruction of the regime."

### **Class Consciousness and Lack of Consciousness: A Debated Dichotomy**

There was one stumbling block to Marx's hope of a working-class revolution, and that was the fact that the working class did not see themselves as one unit, but individually, in terms of 'I' and 'me.' This is known as **lack of consciousness**. A false consciousness is an attitude held by members of a class that does not accurately reflect their objective position. Basically, workers would see themselves as 'I,' as in '*I* am being exploited by *my* boss,' rather than 'we:' '*We* are being exploited by *our* boss.' Marx's revolution to end capitalism and bring down the wealthy controlling class would not come to light as long as the working class was viewing life through a false consciousness.

Among the workers of Bangladesh the level of class consciousness is very often built up, but does not take any revolutionary turn as Marx expected in his classical theory. The ideas of labor class of third world are maneuvered and shaped by the attitudes of bourgeoisie class making a sense of false consciousness which impedes the implementation of Marxian class revolution. The conditions of work and the roles of workers dispose them to solidarity and to overcoming their initial competitiveness in favor of combined action for their collective class interests. Capitalists, however, being constrained by competition on the market, are in structural positions that do not allow them to arrive at a consistent assertion of common interests. The market and the competitive mode of production that is characteristic of capitalism tend to separate individual producers. Marx granted that capitalists also found it possible to transcend their immediate self-interests, but he thought this possible primarily in the political and ideological spheres rather than in the economic. Capitalists, divided by the economic competition among them, evolved a justifying ideology and a political system of domination that served their collective interests. "The State is the form in which the individuals of a ruling class assert their common interests." "The ideas of the ruling class are the ruling ideas." Political power and ideology thus seem to serve the same functions for capitalists that class consciousness serves for the working class. But the symmetry is only

apparent. To Marx, the economic sphere was always the finally decisive realm within which the bourgeoisie was always the victim of the competitiveness inherent in its mode of economic existence. It can evolve a consciousness, but it is always a "false consciousness," that is, a consciousness that does not transcend its being rooted in an economically competitive mode of production. Hence neither the bourgeoisie as a class, nor the bourgeois state, nor the bourgeois ideology can serve truly to transcend the self-interest enjoined by the bourgeoisie. The bourgeois reign is doomed when economic conditions are ripe and when a working class united by solidarity, aware of its common interests and energized by an appropriate system of ideas, confronts its disunited antagonists. Once workers became aware that they are alienated from the process of production, the dusk of the capitalist era has set in.

### **Patterns of Revolution in Garments Industry: Bangladesh Perspective**

The revolutionary movements are very natural and frequent phenomenon in third world countries like Bangladesh. The way revolution should occur does not get any fruitful result what Marx deserved in his theoretical framework over times. In Bangladesh, garments sector is tremendously controlled by the petty bourgeoisie, lumping proletariat and the executive officials of the state. That's why; no political consciousness develops among the general workers of this economic sector. The very concept of class consciousness of third world workers could be easily understood following the current movements in this potential sector. The revolt began on Saturday 20th May, 2013 in Sripur in the Gazipur district of Dhaka. 1,000 garment workers gathered at FS Sweater Factory, refusing to work until 3 arrested fellow workers were released from custody. The factory bosses locked the striking workers in the factory, cutting the power and water supplies. Eventually, the sweltering heat proved too much and by 11 am the workers fought their way out, and then gathered on the Dhaka-Mymensingh highway. Now joined by locals, they barricaded the highway for 6 hours and fought pitched battles with the cops. One person was killed and 70 others, including cops and journalists, were injured.

On the morning of Monday, 22 May at Savar Export Processing Zone (EPZ), a suburb of Dhaka, workers at Universal Garments Limited gathered in front of the factory to demand payment of 3 months owed back wages. They were attacked by factory security staff. In response the workers went to neighboring factories and called out other garment workers for support. The growing group of workers then went from factory to factory calling on other workers to join them; 20,000 workers are reported to have joined this angry procession. By the afternoon hundreds of other factories in Savar EPZ and New EPZ had joined the strikes.

Two factories were torched and 100s more ransacked, over 300 hundred company and management vehicles wrecked. The main roads going through Dhaka were blocked. Eventually the clashes with police escalated and the cops responded with bullets. The news of the escalation spread among the workplaces and drew out most other workers into participating. Fearing further vandalism, the authorities announced closure of over 50 factories located in the areas adjoining to the Dhaka Export Processing Zone for indefinite period. A tense situation is prevailing in the areas, with many contingents of police, the paramilitary Bangladesh Rifles and the Rapid Action Battalion deployed in front of the DEPZ and at others key points. The government agreed to release arrested workers and union officials, and to drop the cases against them. It also promised to set up a "minimum wage board for the garment sector and take steps to meet the demands of garment workers,"<sup>9</sup>

### **Conclusion**

Though Marx had a cherished dream of establishing a class less society across the world raising consciousness among the working class, but it did not succeed due to many socio-economic drawbacks and socio-political factors. In garments sector of Bangladesh, no class movement can occur successfully at all. As a result, class less society directed by Karl Marx is always a utopian scheme.

### **References**

1. A. Panagariya, M.G. Quibria and N. Rao, 1996 *The Emerging Global Trading Environment and Developing Asia*, Manila: Asian Development Bank, p. 6.
2. Entwistle, *The Fashioned Body: 2000 Fashion, Dress and Modern Social Theory*, Cambridge and Oxford: Polity Press, p. 208.
3. Entwistle, *The Fashioned Body, 2000 Fashion, Dress and Modern Social Theory*, Cambridge and Oxford: Polity Press, p. 208.
4. International Labour Organisation, 1996 *Globalization of the Footwear, Textiles and Clothing Industries*, Geneva, p. 6.
5. International Labour Organisation, p *Globalization of the Footwear, Textiles and Clothing Industries*, 6.
6. A. Panagariya, M.G. Quibria and N. Rao, 1996, *The Emerging Global Trading Environment and Developing Asia*, Manila: Asian Development Bank, p. 6.
7. Marx, Karl and Engels, F. 1968. *Manifesto of the Communist Party in Karl Marx and Fredric Engels Selected Works*. London: Lawrence and Wishart

8. Marx, Karl 1859. *A Contribution to the Critique of Political Economy*. Macmillan Press. London
9. 12 New Age, 5 July 2006



## ROLE OF LITERATURE IN AWAKENING OF THE MUSLIMS OF BENGAL

**Humaira Momen\***

Literature may not only reflect the society but also serve as an instrument in social change. Writers who are conscious of the society and its needs are in a position to influence the masses. No wonder, therefore, that literature has contributed to the socio-political movement in many a nation. It was literature which profoundly influenced the French Revolution. Voltaire, Rousseau and Montesquieu exposed the evils of the Old Regime through their masterly writings and thus aroused the passion of the people. In Bengal, there was no revolution of this sort but changes occurred with the passage of time.

The first half of the 19th century saw the beginning of a period of renaissance in Bengal but the Muslims of the province failed to align themselves with the new forces of regeneration. While the Muslims were averse to the new system of education introduced by the British, most of the zemindars (big landlords) belonged to the Hindus who were considered to be more loyal. In view of the situation, even by the end of the century, writers of Muslim Bengal could contribute very little to the national awakening. In fact, they lacked a literary tradition that is living and vital. These factors crippled even the most powerful litterateurs of the community. Thus Mir Mosharraf Hossain's 'Bishad-Sindhu', though an excellent piece of literature, lacked the vitality which marked the work of the contemporary Hindu writers. Similarly, Kaikobad, in spite of his undeniable genius which flowered in the late 19th century, could not achieve greatness because the work of the epic poet lacked a suitable socio-political background. After all, successful literary creation occurs only when the individuals and environment cooperate.

Towards the fag-end of the 19th century and during the early years of the 20th, two persons who wielded the most powerful pen for the promotion of national awakening were Syed Ismail Hossain Shirazee and Maulvi Mujibur Rahman. Shirazee, with all his sentimentalism, sought to break the spell of dejection and lassitude of the members of his community. He tried to arouse the Bengali Muslims through his poetic work 'Onall Prabaha' (or 'Flow of Fire') which was first published in 1900 but later banned by the government.

---

\* A former Head of the Department of History, Badrunnessa Government College. She stood first in the First Class in History in 1964. Later she obtained Master degree in South Asian Studies from the University of Sussex (UK). She is also credited with several publications including a book on Muslim Politics in Bengal.

**Correspondent to:**

This book and his numerous writings in 'Al-Islam' may be considered as the torch-bearers in the development of national consciousness. Maulvi Mujibur Rahman, editor of the English weekly 'The Mussalman' (first published in 1906) spread the gospel of patriotism through his innumerable essays. A staunch nationalist, he advocated for education of the Muslims and organized a group of devotees who were not only the living emblem of Islam but also gallant fighters for freedom.

However, despite the pervasive influence of Rabindranath Tagore in virtually every branch of literature, literary tradition of Muslim Bengal gradually developed portraying Islamic ideas and Muslim culture. The most prominent among the litterateurs of 1920s and 1930s was Kazi Nazrul Islam. Although essentially an apostle of humanism, he gave expression to the gospel of Muslim brotherhood in fervent tone through his 'Bisher Banshi', 'Agni Bina' and 'Bhangar Gaan'. Influenced by the Khilafat Movement, he even dreamt of Pan-Islamism. His poetry also vibrantly echoed the call of Non-Cooperation Movement. Indeed, he was a great freedom fighter in the literary front. His famous poem 'The Rebel' along with some of his prose writings such as the 'Statement of a Political Prisoner' undoubtedly inspired the freedom movement of the country. Aided by His Masters Gramophone Company, Nazrul's innumerable lyrics (especially Gazals) enthralled the Muslim community.

The base established by Nazrul to revive Islamic ideals and Muslim heritage helped other Muslim poets develop their talents. In this connection Shahadat Hossain and Gulam Mustafa deserve special mention. However, more renowned was Jasimuddin as a poet. Although the nature of his work was different as he depicted mostly the scenes of rural Bengal in such masterpieces as 'Shojan Badiar Ghat' and 'Nakshikathar Math', he also contributed to the formation of national identity of Muslim Bengal.

As to the field of prose literature, the contributions of Bengali Muslim writers of the period to national awakening were perhaps more substantial as the main feature of their writings turned to be self-realization and consciousness for self-development. Thus writings (both prose and poetry) of Mozammel Haq (of Nadia) bore traces of Islamic ideals and Muslim heritage, while Munshi Meherullah encouraged his co-religionists to develop literature in Islamic way and foster national consciousness. Munshi Mohammed Reazuddin Ahmed was one of those who took to writing inspired by the idea of Pan Islamism and social reconstruction. Sheikh Abdur Rahman, on the other hand, stressed the need for the preservation of Muslim heritage and for self-development. Muniruzzaman Islamabadi tried to picture in his writings such as 'Bharate Islam Prachar', 'Bharate Muslim Sabhyata', in order to enable the people to get back their self-confidence. Through their numerous prose writings, Maulana Akram Khan, who was actively connected with the Muslim League, Poet Ghulam Mustafa and S. Wajed Ali also contributed to the growth of national consciousness among the Muslims of Bengal.

Further, the period (1920s to mid 30s) saw the publication of a several novels by Muslim writers notably 'Kazi Emdadul Huq's 'Abdullah', Najibur Rahman's 'Gariber Maaya' and

Kazi Nazrul Islam's 'Badhonhara' and 'Mrityokhudha'. Although the characters of common people were drawn realistically in them addressing the social problems of the time, these could hardly have a noticeable impact on the conservative community.

Meanwhile, Roquiah Sakhawat Hussain (popularly known as Begum Rokeya), through her literary works such as 'Abarudh Bashini' and 'Sultanas Dream' tried to show how religious dogmas and social ignorance were destroying the Muslim society. Along with these she founded the Roquiah Sakhawat Memorial School in Calcutta (now Kolkata) for Muslim girls and thus pioneered the advancement of women of the community.

Although the Muslims of Bengal (especially of East Bengal) made some progress in the early decades of the century, that is during the partition of Bengal and its aftermath, their literature still lacked the much needed vitality mainly because of the tardy growth of education. In spite of the provision for separate electorate for Muslims, extension of franchise, emergence of a number of political parties and movements, political consciousness was still confined to a small section of the people of the community.

On the other hand, many of the well-known Muslim writers could not shake off the influence of the Congress. Kazi Abdul Wadud wrote in favour of 'Shashata Banga' (Eternal Bengal) immediately after the annulment of the partition of Bengal. In 1930s he led a secular, free thinker movement which drew in its fold Abul Hossain, Kazi Motahar Hossain and Humayun Kabir. On the other hand, though Bankimchandra's 'Ananda Moth' is widely believed to have betrayed the Muslims, Rezaul Karim considered him as non-communal. But these lines of thought never acquired popularity in Muslim Bengal. Rather in keeping with the realities, a separatist literary trend based on religion gained momentum.

In late 1930s, the provincial elections of 1937, the ascendancy of the Muslim League, the beneficial activities of the new Fazlul Huq Ministry such as the passing of the Bengal Agricultural Debtors' Act and the Bengal Money Lenders' Act, the series of victories of the Calcutta Mohamadan Sporting Club in League Championship and the journalistic endeavours of men like Akram Khan stimulated the Muslims of Bengal. All these were reflected in their literature. For instance, Poet Golam Mostafa felt so much excited by the achievements in the football fields that he composed a lovely poem entitled 'Leaguebijoy na Digbijoy'.

The next decade saw the first manifestations of poetic talent of Farrukh Ahmed which were powerfully directed towards the awakening of the Muslims. The author of 'Satsagarrar Majhi' flashed in the limelight in 1944 during the famine in Bengal for his poem 'laash' (deadbody). About the same time the satirical writings of Abul Munsur Ahmad (notably 'Aina' and 'Food Conference') also contributed to the growth of consciousness of the community. Social corruption and mismanagement, which were eating into the vitals of the community, are the theme of his writings.

In 1940s the Muslim litterateurs of Bengal played a really significant role. It was during this period that the Muslims felt the need for national unity, in order to safeguard their distinct culture from the influence of the Hindu-dominated Congress. The fruit of this realisation was 'Pakistan'. The Pakistan Plan produced a tremendous enthusiasm in the minds of the Muslims of Bengal and this was reflected in their literature.

Perhaps the most powerful writer of the period was Abul Kalam Shamsuddin, editor of Bengali daily 'The Azad', who took an active part in moulding the Bengali mind in the context of the Pakistan Movement. He worked hard for the growth of national consciousness and for popularizing the idea of Pakistan through his numerous essays published in the Azad and Mohammadi (a Bengali monthly). Mujibur Rahman Khan, then a sub-editor of 'the Azad', was also an important figure in the fulfilment of the intellectual idealism centring on Pakistan. He was probably the first to write a book in Bengali on 'Pakistan' in which he discussed the political, philosophical and cultural background of the proposed State.

In fact, both Mujibur Rahman Khan and Abul Kalam Shamsuddin were in the forefront of the East Pakistan Renaissance Society Movement which was launched by the Bengali Muslims after the adoption of the Lahore Resolution to give intellectual support to the Pakistan Movement. Together they changed the mere slogan of Pakistan into an intellectual idealism and inspired many to that idea.

Talebur Rahman is another writer who deserves special mention for publishing in Bengali the idea of Pakistan. In his books 'Sharbaharather Pakistan' (Pakistan for the Downtrodden) and 'Pakistanbader Kromobikash' (Development of the Concept of Pakistan), he was able to trace clearly the history of the Muslim freedom movement, portray the selfish designs of the Congress and lay down logical reasons for the demand for Pakistan. It was he who first coined the expression 'East Pakistan' in his article 'Eastern Pakistan or Greater Bengal' published in the Star of India in April 1941.

In short, as the literary tradition grew and as the situation demanded, Muslim writers of Bengal played their part in awakening their community. Admittedly, some of them seemed to be even ahead of time. But during the critical years, that is during the Pakistan movement, they proved their worth by rising to the occasion. However, it is regrettable that while most of the writers emphasized on the factor of religion many of them failed to pay due attention to the urgent need for tackling large-scale poverty and illiteracy. As a matter of fact, in a real sense, 'awakening' of the community remained incomplete even after the achievement of independence in 1947 under the banner of Pakistan.